

Learn OpenGL

An offline transcript of learnopengl.com

Joey de Vries

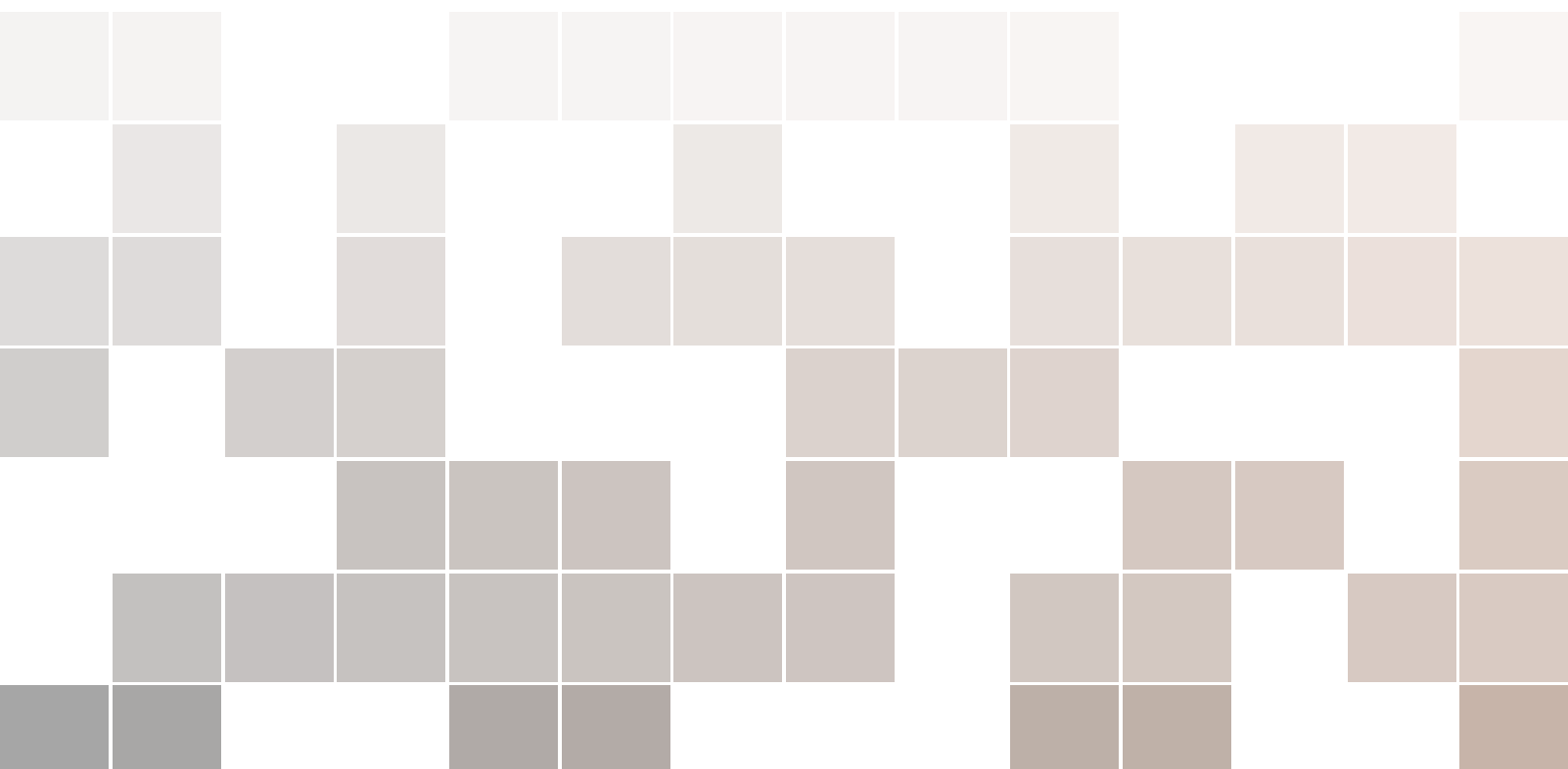

Copyright © 2015 Joey de Vries
PUBLISHED BY ME :)

LEARNOPENGL.COM

Licensed under the Creative Commons Attribution-NonCommercial 3.0 Unported License (the “License”). You may not use this file except in compliance with the License. You may obtain a copy of the License at <http://creativecommons.org/licenses/by-nc/3.0>. Unless required by applicable law or agreed to in writing, software distributed under the License is distributed on an “AS IS” BASIS, WITHOUT WARRANTIES OR CONDITIONS OF ANY KIND, either express or implied. See the License for the specific language governing permissions and limitations under the License.

Second printing, July 2015



Contents

1	Introduction	14
1.1	Prerequisites	14
1.2	Structure	15
1.2.1	Boxes	15
1.2.2	Code	15
1.2.3	Color hints	15
1.2.4	OpenGL Function references	15

I

Getting started

2	OpenGL	17
2.1	Core-profile vs Immediate mode	18
2.2	Extensions	19
2.3	State machine	19
2.4	Objects	20
2.5	Let's get started	21
2.6	Additional resources	21
3	Creating a window	22
3.1	GLFW	22
3.2	Building GLFW	23
3.2.1	CMake	23
3.2.2	Compilation	24

3.3	Our first project	24
3.4	Linking	24
3.4.1	OpenGL library on Windows	25
3.4.2	OpenGL library on Linux	26
3.5	GLEW	26
3.5.1	Building and linking GLEW	26
3.6	Additional resources	27
4	Hello Window	28
4.1	GLEW	29
4.2	Viewport	30
4.3	Ready your engines	30
4.4	One last thing	31
4.5	Input	32
4.6	Rendering	33
5	Hello Triangle	35
5.1	Vertex input	37
5.2	Vertex shader	39
5.3	Compiling a shader	40
5.4	Fragment shader	41
5.4.1	Shader program	42
5.5	Linking Vertex Attributes	43
5.5.1	Vertex Array Object	45
5.5.2	The triangle we've all been waiting for	47
5.6	Element Buffer Objects	48
5.7	Additional resources	51
5.8	Exercises	51
6	Shaders	52
6.1	GLSL	52
6.2	Types	53
6.2.1	Vectors	53
6.3	Ins and outs	54
6.4	Uniforms	56
6.5	Our own shader class	59
6.6	Reading from file	60
6.7	Exercises	62
7	Textures	63
7.1	Texture Wrapping	65
7.2	Texture Filtering	66
7.2.1	Mipmaps	67

7.3	Loading and creating textures	68
7.4	SOIL	69
7.5	Generating a texture	69
7.6	Applying textures	70
7.7	Texture Units	73
7.8	Exercises	76
8	Transformations	77
8.1	Vectors	77
8.2	Scalar vector operations	78
8.3	Vector negation	79
8.4	Addition and subtraction	79
8.5	Length	80
8.6	Vector-vector multiplication	81
8.6.1	Dot product	81
8.6.2	Cross product	82
8.7	Matrices	82
8.8	Addition and subtraction	83
8.9	Matrix-scalar products	84
8.10	Matrix-matrix multiplication	84
8.11	Matrix-Vector multiplication	85
8.12	Identity matrix	86
8.13	Scaling	86
8.14	Translation	87
8.15	Rotation	88
8.16	Combining matrices	89
8.17	In practice	90
8.18	GLM	90
8.19	Exercises	94
9	Coordinate Systems	95
9.1	The global picture	96
9.2	Local space	97
9.3	World space	97
9.4	View space	97
9.5	Clip space	97
9.5.1	Orthographic projection	98
9.5.2	Perspective projection	99
9.6	Putting it all together	102
9.7	Going 3D	102
9.8	More 3D	106
9.8.1	Z-buffer	107

9.8.2	More cubes!	108
9.9	Exercises	109
10	Camera	110
10.1	Camera/View space	110
10.1.1	1. Camera position	111
10.1.2	2. Camera direction	111
10.1.3	3. Right axis	111
10.1.4	4. Up axis	111
10.2	Look At	112
10.3	Walk around	113
10.4	Movement speed	115
10.5	Look around	116
10.6	Euler angles	117
10.7	Mouse input	119
10.8	Zoom	121
10.9	Camera class	122
10.10	Exercises	123
11	Review	124
11.1	Glossary	124

II

Lighting

12	Colors	127
12.1	A lighting scene	129
13	Basic Lighting	133
13.1	Ambient lighting	134
13.2	Diffuse lighting	135
13.3	Normal vectors	136
13.4	Calculating the diffuse color	137
13.5	One last thing	139
13.6	Specular Lighting	141
13.7	Exercises	145
14	Materials	146
14.1	Setting materials	147
14.2	Light properties	149
14.3	Different light colors	151
14.4	Exercises	152

15	Lighting maps	154
15.1	Diffuse maps	154
15.2	Specular maps	157
15.3	Sampling specular maps	158
15.4	Exercises	160
16	Light casters	161
16.1	Directional Light	161
16.2	Point lights	164
16.3	Attenuation	165
16.3.1	Choosing the right values	166
16.3.2	Implementing attenuation	167
16.4	Spotlight	169
16.5	Flashlight	169
16.6	Smooth/Soft edges	172
16.7	Exercises	174
17	Multiple lights	175
17.1	Directional light	176
17.2	Point light	177
17.3	Putting it all together	178
17.4	Exercises	181
18	Review	182
18.1	Glossary	182

III

Model Loading

19	Assimp	185
19.1	A model loading library	186
19.2	Building Assimp	187
20	Mesh	189
20.1	Initialization	190
20.2	Rendering	192
21	Model	194
21.1	Importing a 3D model into OpenGL	195
21.1.1	Assimp to Mesh	197
21.1.2	Indices	199
21.1.3	Material	199

21.2	A large optimization	200
21.3	No more containers!	202
21.4	Exercises	203

IV

Advanced OpenGL

22	Depth testing	205
22.1	Depth test function	206
22.2	Depth value precision	209
22.3	Visualizing the depth buffer	210
22.4	Z-fighting	213
22.4.1	Prevent z-fighting	214
23	Stencil testing	216
23.1	Stencil functions	218
23.2	Object outlining	219
24	Blending	223
24.1	Discarding fragments	224
24.2	Blending	228
24.3	Rendering semi-transparent textures	231
24.4	Don't break the order	233
25	Face culling	235
25.1	Winding order	235
25.2	Face culling	237
25.3	Exercises	239
26	Framebuffers	240
26.1	Creating a framebuffer	240
26.1.1	Texture attachments	242
26.1.2	Renderbuffer object attachments	243
26.2	Rendering to a texture	244
26.3	Post-processing	247
26.3.1	Inversion	247
26.3.2	Grayscale	248
26.4	Kernel effects	249
26.4.1	Blur	251
26.4.2	Edge detection	252
26.5	Exercises	253

27	Cubemaps	254
27.1	Creating a cubemap	255
27.2	Skybox	256
27.3	Loading a skybox	258
27.4	Displaying a skybox	259
27.5	An optimization	261
27.6	Environment mapping	262
27.7	Reflection	262
27.8	Refraction	266
27.9	Dynamic environment maps	267
27.10	Exercises	268
28	Advanced Data	269
28.1	Batching vertex attributes	270
28.2	Copying buffers	271
29	Advanced GLSL	273
29.1	GLSL's built-in variables	273
29.2	Vertex shader variables	273
29.2.1	gl_PointSize	274
29.2.2	gl_VertexID	275
29.3	Fragment shader variables	275
29.3.1	gl_FragCoord	275
29.3.2	gl_FrontFacing	276
29.3.3	gl_FragDepth	277
29.4	Interface blocks	278
29.5	Uniform buffer objects	279
29.6	Uniform block layout	280
29.7	Using uniform buffers	282
29.8	A simple example	284
30	Geometry Shader	288
30.1	Using geometry shaders	291
30.2	Let's build some houses	294
30.3	Exploding objects	299
30.4	Visualizing normal vectors	302
31	Instancing	305
31.1	Instanced arrays	308
31.2	An asteroid field	311

32	Anti Aliasing	317
32.1	Multisampling	318
32.2	MSAA in OpenGL	322
32.3	Off-screen MSAA	323
32.3.1	Multisampled texture attachments	324
32.3.2	Multisampled renderbuffer objects	324
32.3.3	Render to multisampled framebuffer	324
32.4	Custom Anti-Aliasing algorithm	327

V

Advanced Lighting

33	Advanced Lighting	329
33.1	Blinn-Phong	329
34	Gamma Correction	334
34.1	Gamma correction	336
34.2	sRGB textures	338
34.3	Attenuation	339
34.4	Additional resources	341
35	Shadow Mapping	342
35.1	Shadow mapping	343
35.2	The depth map	344
35.2.1	Light space transform	346
35.2.2	Render to depth map	346
35.3	Rendering shadows	348
35.4	Improving shadow maps	352
35.4.1	Shadow acne	352
35.4.2	Peter panning	354
35.4.3	Over sampling	356
35.5	PCF	358
35.6	Orthographic vs projection	360
35.7	Additional resources	361
36	Point Shadows	362
36.1	Generating the depth cubemap	363
36.1.1	Light space transform	365
36.1.2	Depth shaders	366
36.2	Omnidirectional shadow maps	367
36.2.1	Visualizing cubemap depth buffer	371
36.3	PCF	372
36.4	Additional resources	375

37	Normal Mapping	376
37.1	Normal mapping	377
37.2	Tangent space	381
37.2.1	Manual calculation of tangents and bitangents	383
37.2.2	Tangent space normal mapping	385
37.3	Complex objects	389
37.4	One last thing	391
37.5	Additional resources	391
38	Parallax Mapping	392
38.1	Parallax mapping	395
38.2	Steep Parallax Mapping	399
38.3	Parallax Occlusion Mapping	403
38.4	Additional resources	405
39	HDR	406
39.1	Floating point framebuffers	408
39.2	Tone mapping	410
39.2.1	More HDR	412
39.3	Additional resources	412
40	Bloom	413
40.1	Extracting bright color	416
40.2	Gaussian blur	418
40.3	Blending both textures	421
40.4	Additional resources	423
41	Deferred Shading	424
41.1	The G-buffer	426
41.2	The deferred lighting pass	430
41.3	Combining deferred rendering with forward rendering	432
41.4	A larger number of lights	435
41.4.1	Calculating a light's volume or radius	435
41.4.2	How we really use light volumes	437
41.5	Deferred rendering vs forward rendering	438
41.6	Additional resources	439
42	SSAO	440
42.1	Sample buffers	443
42.2	Normal-oriented hemisphere	445
42.3	Random kernel rotations	446
42.4	The SSAO shader	447

42.5	Ambient occlusion blur	451
42.6	Applying ambient occlusion	453
42.7	Additional resources	456

VI In Practice

43	Text Rendering	458
43.1	Classical text rendering: bitmap fonts	458
43.2	Modern text rendering: FreeType	459
43.2.1	Shaders	463
43.2.2	Render line of text	464
43.3	Going further	467
44	2D Game	468
45	Breakout	469
45.1	OpenGL Breakout	470
46	Setting up	472
46.1	Utility	473
46.2	Resource management	474
46.3	Program	474
47	Rendering Sprites	476
47.1	2D projection matrix	476
47.2	Rendering sprites	477
47.2.1	Initialization	478
47.2.2	Rendering	479
47.3	Hello sprite	480
48	Levels	482
48.1	Within the game	485
48.1.1	The player paddle	487
49	Ball	490
50	Collision detection	494
50.1	AABB - AABB collisions	494
50.2	AABB - Circle collision detection	497
51	Collision resolution	501
51.0.1	Collision repositioning	501
51.0.2	Collision direction	502
51.0.3	AABB - Circle collision resolution	503

51.1	Player - ball collisions	505
51.1.1	Sticky paddle	506
51.1.2	The bottom edge	506
51.2	A few notes	507
52	Particles	508
53	Postprocessing	514
53.0.1	Shake it	517
54	Powerups	519
54.0.1	Spawning PowerUps	520
54.0.2	Activating PowerUps	521
54.0.3	Updating PowerUps	524
55	Audio	527
55.1	Irrklang	527
55.1.1	Adding music	528
55.1.2	Adding sounds	529
56	Render text	530
56.1	Player lives	532
56.2	Level selection	533
56.3	Winning	536
57	Final thoughts	539
57.1	Optimizations	539
57.2	Get creative	540

A futuristic cityscape with a flying vehicle in the foreground. The vehicle is dark with blue lights and is flying towards the left. The city is composed of many tall, thin buildings, some of which are illuminated with blue light. The sky is a mix of blue and white, suggesting a bright, hazy day.

1. Introduction

Since you came here you probably want to learn the inner workings of computer graphics and do all the stuff the cool kids do by yourself. Doing things by yourself is extremely fun and resourceful and gives you a great understanding of graphics programming. However, there are a few items that need to be taken into consideration before starting your journey.

1.1 Prerequisites

Since OpenGL is a graphics API and not a platform of its own, it requires a language to operate in and the language of choice is C++, therefore a decent knowledge of the C++ programming language is required for these tutorials. However, I will try to explain most of the concepts used, including advanced C++ topics where required so it is not required to be an expert in C++, but you should be able to write more than just a 'Hello World' program. If you don't have much experience with C++ I can recommend the following free tutorials at www.learncpp.com.

Also, we will be using some math (linear algebra, geometry and trigonometry) along the way and I will try to explain all the required concepts of the math required. However, I'm not a mathematician by heart so even though my explanations might be easy to understand, they will most likely be incomplete. So where necessary I will provide pointers to good resources that explain the material in a more complete fashion. Do not be scared about the mathematical knowledge required before starting your journey into OpenGL; almost all the concepts can be understood with a basic mathematical background and I will try to keep the mathematics to a minimum where possible. Most of the functionality does not even require you to understand all the math as long as you know how to use it.

1.2 Structure

LearnOpenGL is broken down into a number of general subjects. Each subject contains several sections that each explain different concepts in large detail. Each of the subjects can be found at the menu to your left. The subjects are taught in a linear fashion (so it is advised to start from the top to the bottom, unless otherwise instructed) where each page explains the background theory and the practical aspects.

To make the tutorials easier to follow and give them some added structure the site contains *boxes*, *code blocks*, *color hints* and *function references*.

1.2.1 Boxes

Green boxes encompasses some notes or useful features/hints about OpenGL or the subject at hand.

Red boxes will contain warnings or other features you have to be extra careful with.

1.2.2 Code

You will find plenty of small pieces of code in the website that are located in dark-gray boxes with syntax-highlighted code as you can see below:

```
// This box contains code
```

Since these provide only snippets of code, wherever necessary I will provide a link to the entire source code required for a given subject.

1.2.3 Color hints

Some words are displayed with a different color to make it extra clear these words portray a special meaning:

- **Definition**: green words specify a definition i.e. an important aspect/name of something you're likely to hear more often.
- **Program logic**: red words specify function names or class names.
- **Variables**: blue words specify variables including all OpenGL constants.

1.2.4 OpenGL Function references

A particularly well appreciated feature of LearnOpenGL is the ability to review most of OpenGL's functions wherever they show up in the content. Whenever a function is found in the content that is documented at the website, the function will show up with a slightly noticeable underline. You can hover the mouse over the function and after a small interval, a pop-up window will show relevant information about this function including a nice overview of what the function actually does. Hover your mouse over `glEnable` to see it in action.

Now that you got a bit of a feel of the structure of the site, hop over to the Getting Started section to start your journey in OpenGL!



Getting started

2	OpenGL	17
3	Creating a window	22
4	Hello Window	28
5	Hello Triangle	35
6	Shaders	52
7	Textures	63
8	Transformations	77
9	Coordinate Systems	95
10	Camera	110
11	Review	124

A futuristic cityscape with a flying vehicle in the foreground. The vehicle is dark with blue lights and is flying towards the right. The city is composed of tall, thin buildings and is set against a hazy, blue sky.

2. OpenGL

Before starting our journey we should first define what OpenGL actually is. OpenGL is mainly considered an API (an [Application Programming Interface](#)) that provides us with a large set of functions that we can use to manipulate graphics and images. However, OpenGL by itself is not an API, but merely a specification, developed and maintained by the [Khronos Group](#).



The OpenGL specification specifies exactly what the result/output of each function should be and how it should perform. It is then up to the developers *implementing* this specification to come up with a solution of how this function should operate. Since the OpenGL specification does not give us implementation details, the actual developed versions of OpenGL are allowed to have different implementations, as long as their results comply with the specification (and are thus the same to the user).

The people developing the actual OpenGL libraries are usually the graphics card manufacturers. Each graphics card that you buy supports specific versions of OpenGL which are the versions of OpenGL developed specifically for that card (series). When using an Apple system the OpenGL library is maintained by Apple themselves and under Linux there exists a combination of graphic suppliers' versions and hobbyists' adaptations of these libraries. This also means that whenever OpenGL is showing weird behavior that it shouldn't, this is most likely the fault of the graphics cards manufacturers (or whoever developed/maintained the library).

Since most implementations are built by graphics card manufacturers. Whenever there is a bug in the implementation this is usually solved by updating your video card drivers; those drivers include the newest versions of OpenGL that your card supports. This is one of the reasons why it's always advised to occasionally update your graphic drivers.

Khronos publicly hosts all specification documents for all the OpenGL versions. The interested reader can find the OpenGL specification of version 3.3 (which is what we'll be using) [here](#) which is a good read if you want to delve into the details of OpenGL (note how they mostly just describe results and not implementations). The specifications also provide a great reference for finding the **exact** workings of its functions.

2.1 Core-profile vs Immediate mode

In the old days, using OpenGL meant developing in **immediate mode** (also known as the **fixed function pipeline**) which was an easy-to-use method for drawing graphics. Most of the functionality of OpenGL was hidden in the library and developers did not have much freedom at how OpenGL does its calculations. Developers eventually got hungry for more flexibility and over time the specifications became more flexible; developers gained more control over their graphics. The immediate mode is really easy to use and understand, but it is also extremely inefficient. For that reason the specification started to deprecate immediate mode functionality from version 3.2 and started motivating developers to develop in OpenGL's **core-profile** mode which is a division of OpenGL's specification that removed all old deprecated functionality.

When using OpenGL's core-profile, OpenGL forces us to use modern practices. Whenever we try to use one of OpenGL's deprecated functions, OpenGL raises an error and stops drawing. The advantage of learning the modern approach is that it is very flexible and efficient, but unfortunately is also more difficult to learn. The immediate mode abstracted quite a lot from the **actual** operations OpenGL performed and while it was easy to learn, it was hard to grasp how OpenGL actually operates. The modern approach requires the developer to truly understand OpenGL and graphics programming and while it is a bit difficult, it allows for much more flexibility, more efficiency and most importantly a much better understanding of graphics programming.

This is also the reason why our tutorials are geared at Core-Profile OpenGL version 3.3. Although it is more difficult, it is greatly worth the effort.

As of today, much higher versions of OpenGL are published (at the time of writing 4.5) at which you might ask: why do I want to learn OpenGL 3.3 when OpenGL 4.5 is out? The answer to that question is relatively simple. All future versions of OpenGL starting from 3.3 basically add extra useful features to OpenGL without changing OpenGL's core mechanics; the newer versions just introduce slightly more efficient or more useful ways to accomplish the same tasks. The result is that all concepts and techniques remain the same over the modern OpenGL versions so it is perfectly valid to learn OpenGL 3.3. Whenever you're ready and/or more experienced you can easily use specific functionality from more recent OpenGL versions.

When using functionality from the most recent version of OpenGL, only the most modern graphics cards will be able to run your application. This is often why most developers generally target lower versions of OpenGL and optionally enable higher version functionality.

In some tutorials you'll sometimes find more modern features which are noted down as such.

2.2 Extensions

A great feature of OpenGL is its support of extensions. Whenever a graphics company comes up with a new technique or a new large optimization for rendering this is often found in an **extension** implemented in the drivers. If the hardware an application runs on supports such an extension the developer can use the functionality provided by the extension for more advanced or efficient graphics. This way, a graphics developer can still use these new rendering techniques without having to wait for OpenGL to include the functionality in its future versions, simply by checking if the extension is supported by the graphics card. Often, when an extension is popular or very useful it eventually becomes part of future OpenGL versions.

The developer then has to query whether any of these extensions are available (or use an OpenGL extension library). This allows the developer to do things better or more efficient, based on whether an extension is available:

```
if (GL_ARB_extension_name)
{
    // Do cool new and modern stuff supported by hardware
}
else
{
    // Extension not supported: do it the old way
}
```

With OpenGL version 3.3 we rarely need an extension for most techniques, but wherever it is necessary proper instructions are provided.

2.3 State machine

OpenGL is by itself a large state machine: a collection of variables that define how OpenGL should currently operate. The state of OpenGL is commonly referred to as the OpenGL **context**. When using OpenGL, we often change its state by setting some options, manipulating some buffers and then render using the current context.

Whenever we tell OpenGL that we now want to draw lines instead of triangles for example, we change the state of OpenGL by changing some context variable that sets how OpenGL should draw. As soon as we changed the state by telling OpenGL it should draw lines, the next drawing commands will now draw lines instead of triangles.

When working in OpenGL we will come across several **state-changing** functions that change the context and several **state-using** functions that perform some operations based on the current state of OpenGL. As long as you keep in mind that OpenGL is basically one large state machine, most of its functionality will make more sense.

2.4 Objects

The OpenGL libraries are written in C and allows for many derivations in other languages, but in its core it remains a C-library. Since many of C's language-constructs do not translate that well to other higher-level languages, OpenGL was developed with several abstractions in mind. One of those abstractions are objects in OpenGL.

An **object** in OpenGL is a collection of options that represents a subset of OpenGL's state. For example, we could have an object that represents the settings of the drawing window; we could then set its size, how many colors it supports and so on. One could visualize an object as a C-like struct:

```
struct object_name {
    GLfloat option1;
    GLuint option2;
    GLchar[] name;
};
```

Primitive types

Note that when working in OpenGL it is advised to use the primitive types defined by OpenGL. Instead of writing `float` we prefix it with `GL`; the same holds for `int`, `uint`, `char`, `bool` etc. OpenGL defines the memory-layout of their GL primitives in a cross-platform manner since some operating systems may have different memory-layouts for their primitive types. Using OpenGL's primitive types helps to ensure that your application works on multiple platforms.

Whenever we want to use objects it generally looks something like this (with OpenGL's context visualized as a large struct):

```
// The State of OpenGL
struct OpenGL_Context {
    ...
    object* object_Window_Target;
    ...
};
```

```
// Create object
GLuint objectId = 0;
glGenObject(1, &objectId);
// Bind object to context
glBindObject(GL_WINDOW_TARGET, objectId);
// Set options of object currently bound to GL_WINDOW_TARGET
glSetObjectOption(GL_WINDOW_TARGET, GL_OPTION_WINDOW_WIDTH, 800);
glSetObjectOption(GL_WINDOW_TARGET, GL_OPTION_WINDOW_HEIGHT, 600);
// Set context target back to default
glBindObject(GL_WINDOW_TARGET, 0);
```

This little piece of code is a workflow you'll frequently see when working in OpenGL. We first create an object and store a reference to it as an id (the real object data is stored behind the scenes). Then we bind the object to the target location of the context (the location of the example window object target is defined as `GL_WINDOW_TARGET`). Next we set the window options and finally we un-bind the object by setting the current object id of the window target to 0. The options we set are

stored in the object referenced by `objectId` and restored as soon as we bind the object back to `GL_WINDOW_TARGET`.

The code samples provided so far are only approximations of how OpenGL operates; throughout the tutorial you will come across enough actual examples.

The great thing about using these objects is that we can define more than one object in our application, set their options and whenever we start an operation that uses OpenGL's state, we bind the object with our preferred settings. There are objects for example that act as container objects for 3D model data (a house or a character) and whenever we want to draw one of them, we bind the object containing the model data that we want to draw (we first created and set options for these objects). Having several objects allows us to specify many models and whenever we want to draw a specific model, we simply bind the corresponding object before drawing without setting all their options again.

2.5 Let's get started

You now learned a bit about OpenGL as a specification and a library, how OpenGL approximately operates under the hood and a few custom tricks that OpenGL uses. Don't worry if you didn't get all of it; throughout the tutorial we'll walk through each step and you'll see enough examples to really get a grasp of OpenGL. If you're ready for the next step we can start creating an OpenGL context and our first window [here](#).

2.6 Additional resources

- opengl.org: official website of OpenGL.
- [OpenGL registry](#): hosts the OpenGL specifications and extensions for all OpenGL versions.



3. Creating a window

The first thing we need to do to create stunning graphics is to create an OpenGL context and an application window to draw in. However, those operations are specific per operating system and OpenGL purposefully tries to abstract from these operations. This means we have to create a window, define a context and handle user input all by ourselves.

Luckily, there are quite a few libraries out there that already provide the functionality we seek, some specifically aimed at OpenGL. Those libraries save us all the operation-system specific work and give us a window and an OpenGL context to render in. Some of the more popular libraries are GLUT, SDL, SFML and GLFW. For our tutorials we will be using **GLFW**.

3.1 GLFW

GLFW is a library, written in C, specifically targeted at OpenGL providing the bare necessities required for rendering goodies to the screen. It allows us to create an OpenGL context, define window parameters and handle user input which is all that we need.

GLFW >

The focus of this and the next tutorial is getting GLFW up and running, making sure it properly creates an OpenGL context and that it properly displays a window for us to render in. The tutorial will take a step-by-step approach in retrieving, building and linking the GLFW library. For this tutorial we will use the Microsoft Visual Studio 2012 IDE. If you're not using Visual Studio (or an older version) don't worry, the process will be similar on most other IDEs. Visual Studio 2012 (or any other version) can be downloaded for free from Microsoft by selecting the **express** version.

3.2 Building GLFW

GLFW can be obtained from their webpage's [download](#) page. GLFW already has pre-compiled binaries and header files for Visual Studio 2012/2013, but for completeness' sake we will compile GLFW ourselves from the source code. So let's download the *Source package*.

If you're using their pre-compiled binaries, be sure to download the 32 bit versions and not the 64 bit versions (unless you know exactly what you're doing). The 64 bit versions have reportedly been causing weird errors for most readers.

Once you've downloaded the source package, extract it and open its content. We are only interested in a few items:

- The resulting library from compilation.
- The **include** folder.

Compiling the library from the source code guarantees that the resulting library is perfectly tailored for your CPU/OS, a luxury pre-compiled binaries do not always provide (sometimes, pre-compiled binaries are not available for your system). The problem with providing source code to the open world however is that not everyone uses the same IDE for developing their application, which means the project/solution files provided may not be compatible with other people's IDEs. So people then have to build their own project/solution with the given `.c/.cpp` and `.h/.hpp` files, which is cumbersome. Exactly for those reasons there is a tool called CMake.

3.2.1 CMake

CMake is a tool that can generate project/solution files of the user's choice (e.g. Visual Studio, Code::Blocks, Eclipse) from a collection of source code files using pre-defined CMake scripts. This allows us to generate a Visual Studio 2012 project file from GLFW's source package which we can use to compile the library. First we need to download and install CMake that can be found on their [download](#) page. I used the Win32 Installer.

Once CMake is installed you can choose to run CMake from the command line or via their GUI. Since we're not trying to overcomplicate things we're going to use the GUI. CMake requires a source code folder and a destination folder for the binaries. As the source code folder we're going to choose the root folder of the downloaded GLFW source package and for the build folder we're creating a new directory *build* and then select that directory.

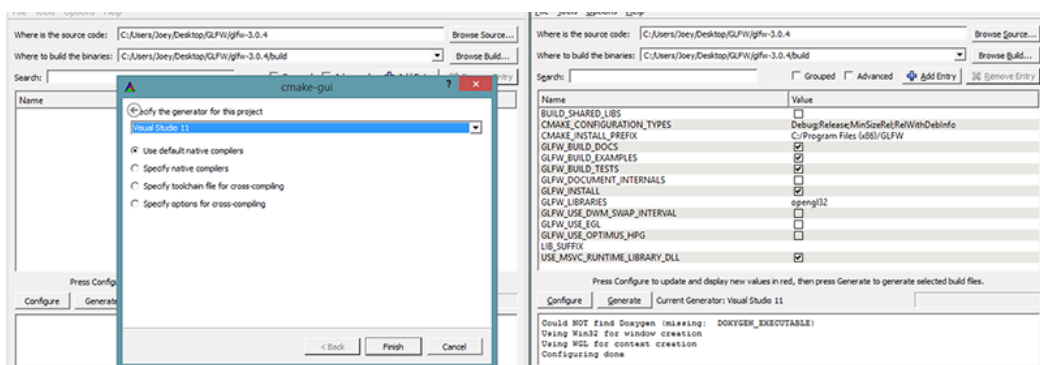

Once the source and destination folders have been set, click the **Configure** button so CMake can read the required settings and the source code. We then have to choose the generator for the

project and since we're using Visual Studio 2012 we will choose the `Visual Studio 11` option (Visual Studio 2012 is also known as Visual Studio 11). CMake will then display the possible build options to configure the resulting library. We can leave them to their default values and click `Configure` again to store the settings. Once the settings have been set, we can click `Generate` and the resulting project files will be generated in your `build` folder.

3.2.2 Compilation

In the `build` folder a file named `GLFW.sln` can be found and we open it with Visual Studio 2012. Since CMake generated a project file that already contains the proper configuration settings we can hit the `Build Solution` button and the resulting compiled library can be found in `src/Debug` named `glfw3.lib` (note, we're using version 3).

Once the library is generated we need to make sure the IDE knows where to find the library and the include files. There are two approaches in doing this:

1. We find the `/lib` and `/include` folders of the IDE/Compiler and add the content of GLFW's `include` folder to the IDE's `/include` folder and similarly add `glfw3.lib` to the IDE's `/lib` folder. This works, but this is not the recommended approach. It's hard to keep track of your library/include files and a new installation of your IDE/Compiler will result in lost files.
2. The recommended approach is to create a new set of directories at a location of your choice that contains all the header files/libraries from third parties to which you can refer to using your IDE/Compiler. I personally use a single folder that contains a `Libs` and `Include` folder where I store all my library and header files respectively for OpenGL projects. Now all my third party libraries are organized within a single location (that could be shared across multiple computers). The requirement is however, that each time we create a new project we have to tell the IDE where to find those directories.

Once the required files are stored at a location of your choice, we can start creating our first OpenGL project with GLFW!

3.3 Our first project

First, let's open up Visual Studio and create a new project. Choose Visual C++ if multiple options are given and take the `Empty Project` (don't forget to give your project a suitable name). We now have a workspace to create our very first OpenGL application!

3.4 Linking

In order for the project to use GLFW we need to **link** the library with our project. This can be done by specifying we want to use `glfw3.lib` in the linker settings, but our project does not yet know where to find `glfw3.lib` since we pasted our third party libraries to different directories. We thus need to add those directories to the project first.

We can add those directories (where VS should search for libraries/include-files) by going to the project properties (right-click the project name in the solution explorer) and then go to `VC++ Directories` as can be seen in the image below:

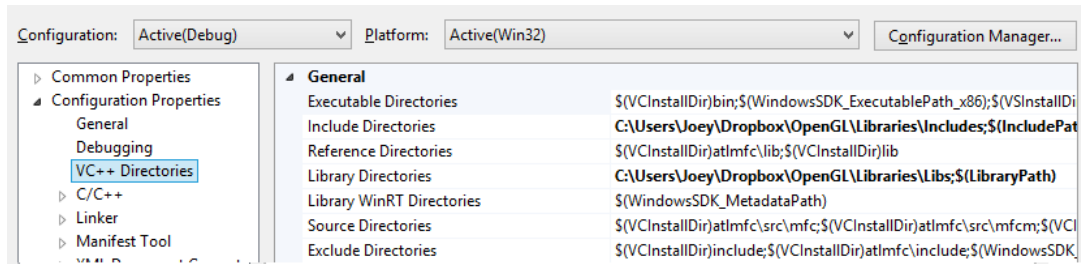

From there on out you can add your own directories to let the project know where to search. This can be done by manually inserting it into the text or clicking the appropriate location string and selecting the <Edit...> option where you'll see the following image for the Include Directories case:

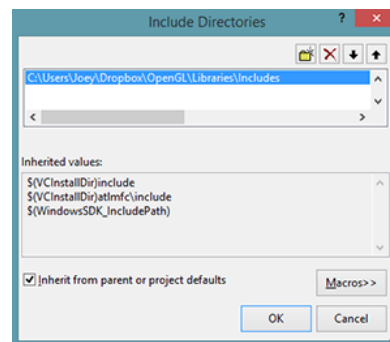

Here you can add as many extra directories as you'd like and from that point on the IDE will also search those directories when searching for header files, so as soon as your Include folder from GLFW is included, you will be able to find all the header files for GLFW by including <GLFW/...>. The same applies for the library directories.

Since VS can now find all the required files we can finally link GLFW to the project by going to the Linker tab and selecting input:

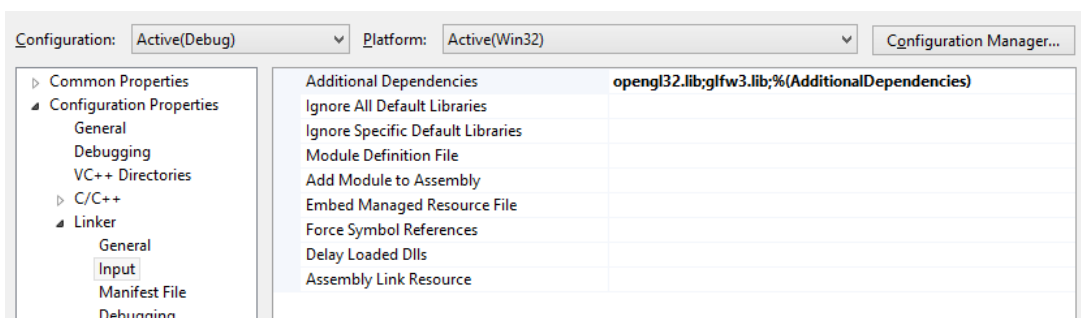

To then link to a library you'd have to specify the name of the library to the linker. Since the library name is `glfw3.lib`, we add that to the Additional Dependencies field (either manually or using the <Edit...> option) and from that point on GLFW will be linked when we compile. Aside from GLFW you should also add a link entry to the OpenGL library, but this might differ per operating system:

3.4.1 OpenGL library on Windows

If you're on Windows the OpenGL library `opengl32.lib` comes with the Microsoft SDK which is installed by default when you install Visual Studio. Since this tutorial uses the VS compiler and

is on windows we add `opengl32.lib` to the linker settings.

3.4.2 OpenGL library on Linux

On Linux systems you need to link to the `libGL.so` library by adding `-lGL` to your linker settings. If you can't find the library you probably need to install any of the Mesa, NVidia or AMD dev packages, but I won't delve into the details since this is platform-specific (plus I'm not a Linux expert).

Then, once you've added both the GLFW and OpenGL library to the linker settings you can include the headers of GLFW as follows:

```
#include <GLFW\glfw3.h>
```

This concludes the setup and configuration of GLFW.

3.5 GLEW

We're still not quite there yet, since there is one other thing we still need to do. Since OpenGL is a standard/specification it is up to the driver manufacturer to implement the specification to a driver that the specific graphics card supports. Since there are many different versions of OpenGL drivers, the location of most of its functions is not known at compile-time and needs to be queried at run-time. It is then the task of the developer to retrieve the location of the functions he/she needs and store them in function pointers for later use. Retrieving those locations is OS-specific and in Windows it looks something like this:

```
// Define the function's prototype
typedef void (*GL_GENBUFFERS) (GLsizei, GLuint*);
// Find the function and assign it to a function pointer
GL_GENBUFFERS glGenBuffers = (GL_GENBUFFERS)wglGetProcAddress("glGenBuffers");
// Function can now be called as normal
GLuint buffer;
glGenBuffers(1, &buffer);
```

As you can see the code looks complex and it's a cumbersome process to do this for each function you might need that is not yet declared. Thankfully, there are libraries for this purpose as well where **GLEW** is the most popular and up-to-date library.

3.5.1 Building and linking GLEW

GLEW stands for OpenGL Extension Wrangler Library and manages all that cumbersome work we talked about. Since GLEW is again a library, we need to build/link it to our project. GLEW can be downloaded from their [download](#) page and you can either choose to use their pre-compiled binaries if your target platform is listed or compile them from the source as we've done with GLFW. Again, use GLEW's 32 bit libraries if you're not sure what you're doing.

We will be using the *static* version of GLEW which is `glew32s.lib` (notice the *s* extension) so add the library to your library folder and also add the `include` content to your include folder.

Then we can link GLEW to the project by adding `glew32s.lib` to the linker settings in VS. Note that GLFW3 is also (by default) built as a static library.

Static linking of a library means that during compilation the library will be integrated in your binary file. This has the advantage that you do not need to keep track of extra files, but only need to release your single binary. The disadvantage is that your executable becomes larger and when a library has an updated version you need to re-compile your entire application.

Dynamic linking of a library is done via `.dll` files or `.so` files and then the library code and your binary code stays separated, making your binary smaller and updates easier. The disadvantage is that you'd have to release your DLLs with the final application.

If you want to use GLEW via their static library we have to define a pre-processor variable `GLEW_STATIC` before including GLEW.

```
#define GLEW_STATIC
#include <GL/glew.h>
```

If you want to link dynamically you can omit the `GLEW_STATIC` define. Keep in mind that if you want to link dynamically you'll also have to copy the `.DLL` to the same folder of your binary.

For Linux users compiling with GCC the following command line options might help you compile the project `-lGLEW -lglfw3 -lGL -lX11 -lpthread -lXrandr -lXi`. Not correctly linking the corresponding libraries will generate many *undefined reference* errors.

Now that we successfully compiled and linked both GLFW and GLEW we're set to go for the [next](#) tutorial where we'll discuss how we can actually use GLFW and GLEW to configure an OpenGL context and spawn a window. Be sure to check that all your include and library directories are correct and that the library names in the linker settings match with the corresponding libraries. If you're still stuck, check the comments, check any of the additional resources or ask your question below.

3.6 Additional resources

- [Building applications](#): provides great info about the compilation/linking process of your application and a large list of possible errors (plus solutions) that might come up.
- [GLFW with Code::Blocks](#): building GLFW in Code::Blocks IDE.
- [Running CMake](#): short overview of how to run CMake on both Windows and Linux.
- [Writing a build system under Linux](#): an autotools tutorial by Wouter Verholst on how to write a build system in Linux, specifically targeted for these tutorials.
- [Polytonic/Glitter](#): a simple boilerplate project that comes pre-configured with all relevant libraries; great for if you want a sample project for the LearnOpenGL tutorials without the hassle of having to compile all the libraries yourself.



4. Hello Window

Let's see if we can get GLFW up and running. First, create a `.cpp` file and add the following includes to the top of your newly created file. Note that we define `GLEW_STATIC` since we're using the static version of the GLEW library.

```
// GLEW
#define GLEW_STATIC
#include <GL/glew.h>
// GLFW
#include <GLFW/glfw3.h>
```

Be sure to include GLEW before GLFW. The include file for GLEW contains the correct OpenGL header includes (like `GL/gl.h`) so including GLEW before other header files that require OpenGL does the trick.

Next, we create the `main` function where we will instantiate the GLFW window:

```
int main()
{
    glfwInit();
    glfwWindowHint(GLFW_CONTEXT_VERSION_MAJOR, 3);
    glfwWindowHint(GLFW_CONTEXT_VERSION_MINOR, 3);
    glfwWindowHint(GLFW_OPENGL_PROFILE, GLFW_OPENGL_CORE_PROFILE);
    glfwWindowHint(GLFW_RESIZABLE, GL_FALSE);

    return 0;
}
```

In the `main` function we first initialize GLFW with `glfwInit`, after which we can configure GLFW using `glfwWindowHint`. The first argument of `glfwWindowHint` tells us what option we want to configure, where we can select the option from a large enum of possible options

prefixed with `GLFW_`. The second argument is an integer that sets the value of our option. A list of all the possible options and its corresponding values can be found at [GLFW's window handling](#) documentation. If you try to run the application now and it gives a lot of *undefined reference* errors it means you didn't successfully link the GLFW library.

Since the focus of this website is on OpenGL version 3.3 we'd like to tell GLFW that 3.3 is the OpenGL version we want to use. This way GLFW can make the proper arrangements when creating the OpenGL context. This ensures that when a user does not have the proper OpenGL version GLFW fails to run. We set the major and minor version both to 3. We also tell GLFW we want to explicitly use the core-profile and that the window should not be resizable by a user. Telling GLFW explicitly that we want to use the core-profile will result in `invalid operation` errors whenever we call one of OpenGL's legacy functions, which is a nice reminder when we accidentally use old functionality where we'd rather stay away from. Note that on Mac OS X you also need to add `glfwWindowHint(GLFW_OPENGL_FORWARD_COMPAT, GL_TRUE);` to your initialization code for it to work.

Make sure you have OpenGL versions 3.3 or higher installed on your system/hardware otherwise the application will crash or display undefined behavior. To find the OpenGL version on your machine either call `glxinfo` on Linux machines or use a utility like the [OpenGL Extension Viewer](#) for Windows. If your supported version is lower try to check if your video card supports OpenGL 3.3+ (otherwise it's really old) and/or update your drivers.

Next we're required to create a window object. This window object holds all the windowing data and is used quite frequently by GLFW's other functions.

```
GLFWwindow* window = glfwCreateWindow(800, 600, "LearnOpenGL", nullptr,
    nullptr);
if (window == nullptr)
{
    std::cout << "Failed to create GLFW window" << std::endl;
    glfwTerminate();
    return -1;
}
glfwMakeContextCurrent(window);
```

The `glfwCreateWindow` function requires the window width and height as its first two arguments respectively. The third argument allows us to create a name for the window; for now we call it "LearnOpenGL" but you're allowed to name it however you like. We can ignore the last 2 parameters. The function returns a `GLFWwindow` object that we'll later need for other GLFW operations. After that we tell GLFW to make the context of our window the main context on the current thread.

4.1 GLEW

In the previous tutorial we mentioned that GLEW manages function pointers for OpenGL so we want to initialize GLEW before we call any OpenGL functions.

```
glewExperimental = GL_TRUE;
```

```
if (glewInit() != GLEW_OK)
{
    std::cout << "Failed to initialize GLEW" << std::endl;
    return -1;
}
```

Notice that we set the `glewExperimental` variable to `GL_TRUE` before initializing GLEW. Setting `glewExperimental` to true ensures GLEW uses more modern techniques for managing OpenGL functionality. Leaving it to its default value of `GL_FALSE` might give issues when using the core profile of OpenGL.

4.2 Viewport

Before we can start rendering we have to do one last thing. We have to tell OpenGL the size of the rendering window so OpenGL knows how we want to display the data and coordinates with respect to the window. We can set those *dimensions* via the `glViewport` function:

```
glViewport(0, 0, 800, 600);
```

The first two parameters set the location of the lower left corner of the window. The third and fourth parameter set the width and height of the rendering window, which is the same as the GLFW window. We could actually set this at values smaller than the GLFW dimensions; then all the OpenGL rendering would be displayed in a smaller window and we could for example display other elements outside the OpenGL viewport.

Behind the scenes OpenGL uses the data specified via `glViewport` to transform the 2D coordinates it processed to coordinates on your screen. For example, a processed point of location $(-0.5, 0.5)$ would (as its final transformation) be mapped to $(200, 450)$ in screen coordinates. Note that processed coordinates in OpenGL are between -1 and 1 so we effectively map from the range (-1 to 1) to (0, 800) and (0, 600).

4.3 Ready your engines

We don't want the application to draw a single image and then immediately quit and close the window. We want the application to keep drawing images and handling user input until the program has been explicitly told to stop. For this reason we have to create a while loop, that we now call the *game loop*, that keeps on running until we tell GLFW to stop. The following code shows a very simple game loop:

```
while (!glfwWindowShouldClose(window))
{
    glfwPollEvents();
    glfwSwapBuffers(window);
}
```

The `glfwWindowShouldClose` function checks at the start of each loop iteration if GLFW has been instructed to close, if so, the function returns `true` and the game loop stops running, after which we can close the application.

The `glfwPollEvents` function checks if any events are triggered (like keyboard input or mouse movement events) and calls the corresponding functions (which we can set via callback methods). We usually call eventprocessing functions at the start of a loop iteration.

The `glfwSwapBuffers` will swap the color buffer (a large buffer that contains color values for each pixel in GLFW's window) that has been used to draw in during this iteration and show it as output to the screen.

Double buffer

When an application draws in a single buffer the resulting image might display flickering issues. This is because the resulting output image is not drawn in an instant, but drawn pixel by pixel and usually from left to right and top to bottom. Because these images are not displayed at an instant to the user, but rather via a step by step generation the result may contain quite a few artifacts. To circumvent these issues, windowing applications apply a double buffer for rendering. The **front** buffer contains the final output image that is shown at the screen, while all the rendering commands draw to the **back** buffer. As soon as all the rendering commands are finished we **swap** the back buffer to the front buffer so the image is instantly displayed to the user, removing all the aforementioned artifacts.

4.4 One last thing

As soon as we exit the game loop we would like to properly clean/delete all resources that were allocated. We can do this via the `glfwTerminate` function that we call at the end of the `main` function.

```
glfwTerminate();  
return 0;
```

This will clean up all the resources and properly exit the application. Now try to compile your application and if everything went well you should see the following output:

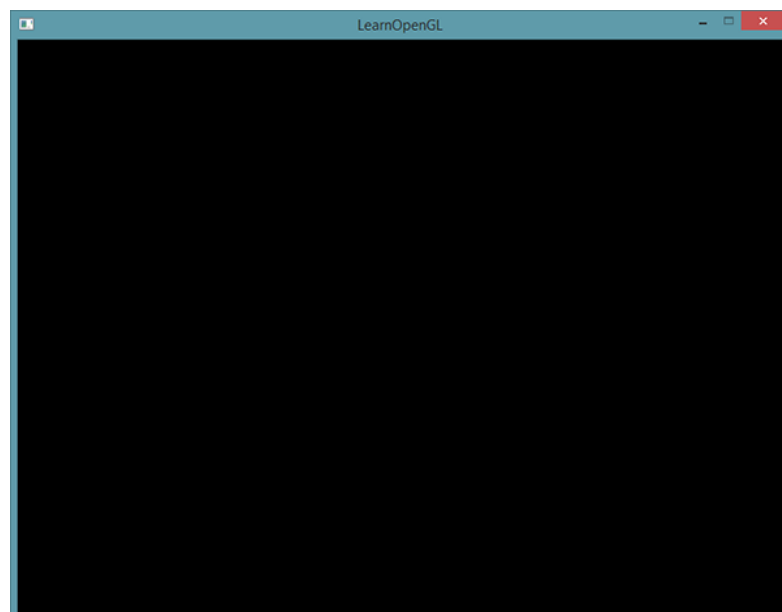

If it's a very dull and boring black image, you did things right! If you didn't get the right image or you're confused as to how everything fits together, check the full source code [here](#).

If you have issues compiling the application, first make sure all your linker options are set correctly and that you properly included the right directories in your IDE (as explained in the previous tutorial). Also make sure your code is correct; you can easily verify it by looking at the source code. If you still have any issues, post a comment below with your issue and me and/or the community will try to help you.

4.5 Input

We also want to have some form of input control in GLFW and we can achieve this using GLFW's callback functions. A **callback function** is basically a function pointer that you can set that GLFW can call at an appropriate time. One of those callback functions that we can set is the `KeyCallback` function, which should be called whenever the user interacts with the keyboard. The prototype of this function is as follows:

```
void key_callback(GLFWwindow* window, int key, int scancode, int action,
                 int mode);
```

The key input function takes a `GLFWwindow` as its first argument, an integer that specifies the key pressed, an action that specifies if the key is pressed or released and an integer representing some bit flags to tell you if `shift`, `control`, `alt` or `super` keys have been pressed. Whenever a user pressed a key, GLFW calls this function and fills in the proper arguments for you to process.

```
void key_callback(GLFWwindow* window, int key, int scancode, int action,
                 int mode)
{
    // When a user presses the escape key, we set the WindowShouldClose
    // property to true,
    // closing the application
    if(key == GLFW_KEY_ESCAPE && action == GLFW_PRESS)
        glfwSetWindowShouldClose(window, GL_TRUE);
}
```

In our (newly created) `key_callback` function we check if the key pressed equals the escape key and if it was pressed (not released) we close GLFW by setting its `WindowShouldClose` property to `true` using `glfwSetWindowShouldClose`. The next condition check of the main `while` loop will then fail and the application closes.

The last thing left to do is register the function with the proper callback via GLFW. This is done as follows:

```
glfwSetKeyCallback(window, key_callback);
```

There are many callback functions we can set to register our own functions. For example, we can make a callback function to process window size changes, to process error messages etc. We register the callback functions after we've created the window and before the game loop is initiated.

4.6 Rendering

We want to place all the rendering commands in the game loop, since we want to execute all the rendering commands each iteration of the loop. This would look a bit like this:

```
// Program loop
while(!glfwWindowShouldClose(window))
{
    // Check and call events
    glfwPollEvents();

    // Rendering commands here
    ...

    // Swap the buffers
    glfwSwapBuffers(window);
}
```

Just to test if things actually work we want to clear the screen with a color of our choice. At the start of each render iteration we always want to clear the screen otherwise we would still see the results from the previous iteration (this could be the effect you're looking for, but usually you don't). We can clear the screen's color buffer using the `glClearColor` function where we pass in buffer bits to specify which buffer we would like to clear. The possible bits we can set are `GL_COLOR_BUFFER_BIT`, `GL_DEPTH_BUFFER_BIT` and `GL_STENCIL_BUFFER_BIT`. Right now we only care about the color values so we only clear the color buffer.

```
glClearColor(0.2f, 0.3f, 0.3f, 1.0f);
glClear(GL_COLOR_BUFFER_BIT);
```

Note that we also set a color via `glClearColor` to clear the screen with. Whenever we call `glClear` and clear the color buffer, the entire colorbuffer will be filled with the color as configured by `glClearColor`. This will result in a dark green-blueish color.

As you might recall from the *OpenGL* tutorial, the `glClearColor` function is a *state-setting* function and `glClear` is a *state-using* function in that it uses the current state to retrieve the clearing color from.

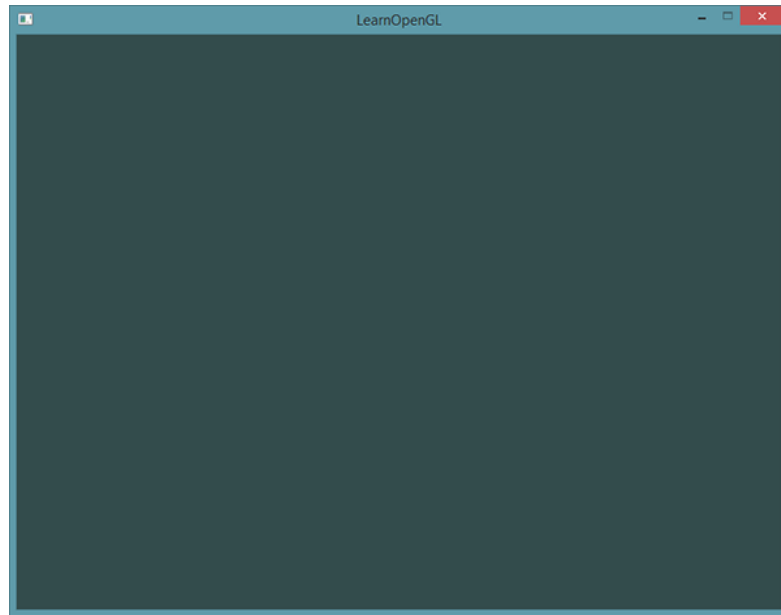

The full source code of the application can be found [here](#).

So right now we got everything ready to fill the game loop with lots of rendering calls, but that's for the [next](#) tutorial. I think we've been rambling long enough here.

A futuristic cityscape with a flying vehicle in the foreground. The vehicle is dark with blue lights and is flying towards the left. The city is composed of tall, thin buildings and is shrouded in a light mist or fog. The sky is a pale blue.

5. Hello Triangle

In OpenGL everything is in 3D space, but the screen and window are a 2D array of pixels so a large part of OpenGL's work is about transforming all 3D coordinates to 2D pixels that fit on your screen. The process of transforming 3D coordinates to 2D coordinates is managed by the **graphics pipeline** of OpenGL. The graphics pipeline can be divided into two large parts: the first transforms your 3D coordinates into 2D coordinates and the second part transforms the 2D coordinates into actual colored pixels. In this tutorial we'll briefly discuss the graphics pipeline and how we can use it to our advantage to create some fancy pixels.

There is a difference between a 2D coordinate and a pixel. A 2D coordinate is a very precise representation of where a point is in 2D space, while a 2D pixel is an approximation of that point limited by the resolution of your screen/window.

The graphics pipeline takes as input a set of 3D coordinates and transforms these to colored 2D pixels on your screen. The graphics pipeline can be divided into several steps where each step requires the output of the previous step as its input. All of these steps are highly specialized (they have one specific function) and can easily be executed in parallel. Because of their parallel nature most graphics cards of today have thousands of small processing cores to quickly process your data within the graphics pipeline by running small programs on the GPU for each step of the pipeline. These small programs are called **shaders**.

Some of these shaders are configurable by the developer which allows us to write our own shaders to replace the existing default shaders. This gives us much more fine-grained control over specific parts of the pipeline and because they run on the GPU, they can also save us valuable CPU time. Shaders are written in the **OpenGL Shading Language (GLSL)** and we'll delve more into that in the next tutorial.

Below you'll find an abstract representation of all the stages of the graphics pipeline. Note that the blue sections represent sections where we can inject our own shaders.

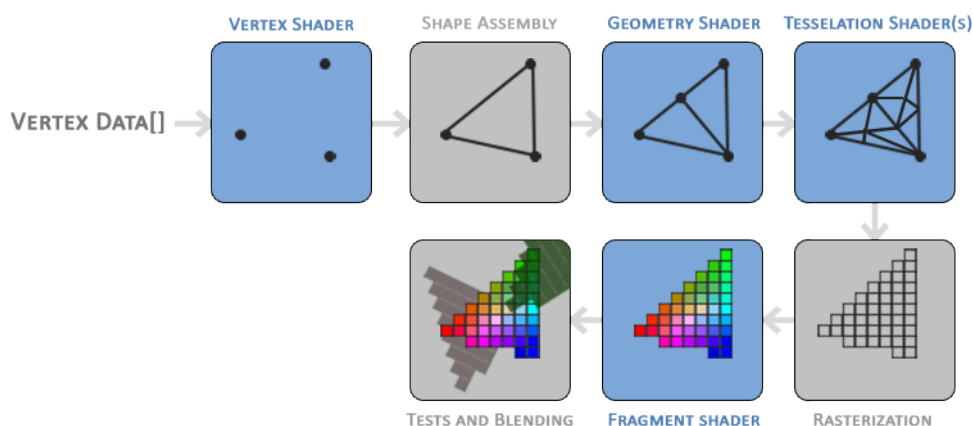

As you can see the graphics pipeline contains a large number of sections that each handle one specific part of converting your vertex data to a fully rendered pixel. We will briefly explain each part of the pipeline in a simplified way to give you a good overview of how the pipeline operates.

As input to the graphics pipeline we pass in a list of three 3D coordinates that should form a triangle in an array here called Vertex Data; this vertex data is a collection of vertices. A **vertex** is basically a collection of data per 3D coordinate. This vertex's data is represented using **vertex attributes** that can contain any data we'd like but for simplicity's sake let's assume that each vertex consists of just a 3D position and some color value.

In order for OpenGL to know what to make of your collection of coordinates and color values OpenGL requires you to hint what kind of render types you want to form with the data. Do we want the data rendered as a collection of points, a collection of triangles or perhaps just one long line? Those hints are called **primitives** and are given to OpenGL while calling any of the drawing commands. Some of these hints are `GL_POINTS`, `GL_TRIANGLES` and `GL_LINE_STRIP`.

The first part of the pipeline is the **vertex shader** that takes as input a single vertex. The main purpose of the vertex shader is to transform 3D coordinates into different 3D coordinates (more on that later) and the vertex shader allows us to do some basic processing on the vertex attributes.

The **primitive assembly** stage takes as input all the vertices (or vertex if `GL_POINTS` is chosen) from the vertex shader that form a primitive and assembles all the point(s) in the primitive shape given; in this case a triangle.

The output of the primitive assembly stage is passed to the **geometry shader**. The geometry shader takes as input a collection of vertices that form a primitive and has the ability to generate other shapes by emitting new vertices to form new (or other) primitive(s). In this example case, it generates a second triangle out of the given shape.

The **tessellation shaders** have the ability to **subdivide** the given primitive into many smaller primitives. This allows you to for example create much smoother environments by creating more triangles the smaller the distance to the player.

The output of the tessellation shaders is then passed on to the **rasterization stage** where it maps

the resulting primitive to the corresponding pixels on the final screen, resulting in fragments for the fragment shader to use. Before the fragment shaders runs, **clipping** is performed. Clipping discards any fragments that are outside your view, increasing performance.

A fragment in OpenGL is all the data required for OpenGL to render a single pixel.

The main purpose of the **fragment shader** is to calculate the final color of a pixel and this is usually the stage where all the advanced OpenGL effects occur. Usually the fragment shader contains data about the 3D scene that it can use to calculate the final pixel color (like lights, shadows, color of the light and so on).

After all the corresponding color values have been determined, the final object will then pass through one more stage that we call the **alpha test** and **blending** stage. This stage checks the corresponding depth (and stencil) value (we'll get to those later) of the fragment and uses those to check if the resulting fragment is in front or behind other objects and should be discarded accordingly. The stage also checks for **alpha** values (alpha values define the opacity of an object) and **blends** the objects accordingly. So even if a pixel output color is calculated in the fragment shader, the final pixel color could still be something entirely different when rendering multiple triangles.

As you can see, the graphics pipeline is quite a complex whole and contains many configurable parts. However, for almost all the cases we only have to work with the vertex and fragment shader. The geometry shader and the tessellation shaders are optional and usually left to their default shaders.

In Modern OpenGL we are **required** to define at least a vertex and fragment shader of our own (there are no default vertex/fragment shaders on the GPU). For this reason it is often quite difficult to start learning Modern OpenGL since a great deal of knowledge is required before being able to render your first triangle. Once you do get to finally render your triangle at the end of this chapter you will end up knowing a lot more about graphics programming.

5.1 Vertex input

To start drawing something we have to first give OpenGL some input vertex data. OpenGL is a 3D graphics library so all coordinates that we specify in OpenGL are in 3D (x, y and z coordinate). OpenGL doesn't simply transform **all** your 3D coordinates to 2D pixels on your screen; OpenGL only processes 3D coordinates when they're in a specific range between -1.0 and 1.0 on all 3 axes (x, y and z). All coordinates within this so called **normalized device coordinates** range will end up visible on your screen (and all coordinates outside this region won't).

Because we want to render a single triangle we want to specify a total of three vertices with each vertex having a 3D position. We define them in normalized device coordinates (the visible region of OpenGL) in a `GLfloat` array:

```
GLfloat vertices[] = {
    -0.5f, -0.5f, 0.0f,
     0.5f, -0.5f, 0.0f,
     0.0f, 0.5f, 0.0f
}
```

```
};
```

Because OpenGL works in 3D space we render a 2D triangle with each vertex having a z coordinate of 0.0 . This way the *depth* of the triangle remains the same making it look like it's 2D.

Normalized Device Coordinates (NDC)

Once your vertex coordinates have been processed in the vertex shader, they should be in **normalized device coordinates** which is a small space where the x , y and z values vary from -1.0 to 1.0 . Any coordinates that fall outside this range will be discarded/clipped and won't be visible on your screen. Below you can see the triangle we specified within normalized device coordinates (ignoring the z axis):

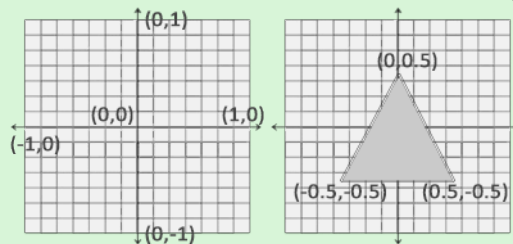

Unlike usual screen coordinates the positive y -axis points in the up-direction and the $(0, 0)$ coordinates are at the center of the graph, instead of top-left. Eventually you want all the (transformed) coordinates to end up in this coordinate space, otherwise they won't be visible.

Your NDC coordinates will then be transformed to **screen-space coordinates** via the **viewport transform** using the data you provided with `glViewport`. The resulting screen-space coordinates are then transformed to fragments as inputs to your fragment shader.

With the vertex data defined we'd like to send it as input to the first process of the graphics pipeline: the vertex shader. This is done by creating memory on the GPU where we store the vertex data, configure how OpenGL should interpret the memory and specify how to send the data to the graphics card. The vertex shader then processes as much vertices as we tell it to from its memory.

We manage this memory via so called **vertex buffer objects (VBO)** that can store a large number of vertices in the GPU's memory. The advantage of using those buffer objects is that we can send large batches of data all at once to the graphics card without having to send data a vertex a time. Sending data to the graphics card from the CPU is relatively slow, so wherever we can we try to send as much data as possible at once. Once the data is in the graphics card's memory the vertex shader has almost instant access to the vertices making it extremely fast

A vertex buffer object is our first occurrence of an OpenGL object as we've discussed in the [OpenGL tutorial](#). Just like any object in OpenGL this buffer has a unique ID corresponding to that buffer, so we can generate one with a buffer ID using the `glGenBuffers` function:

```
GLuint VBO;
glGenBuffers(1, &VBO);
```

OpenGL has many types of buffer objects and the buffer type of a vertex buffer object is `GL_ARRAY_BUFFER`. OpenGL allows us to bind to several buffers at once as long as they have a different buffer type. We can bind the newly created buffer to the `GL_ARRAY_BUFFER` target with the `glBindBuffer` function:

```
glBindBuffer(GL_ARRAY_BUFFER, VBO);
```

From that point on any buffer calls we make (on the `GL_ARRAY_BUFFER` target) will be used to configure the currently bound buffer, which is `VBO`. Then we can make a call to `glBufferData` function that copies the previously defined vertex data into the buffer's memory:

```
glBufferData(GL_ARRAY_BUFFER, sizeof(vertices), vertices, GL_STATIC_DRAW);
```

`glBufferData` is a function specifically targeted to copy user-defined data into the currently bound buffer. Its first argument is the type of the buffer we want to copy data into: the vertex buffer object currently bound to the `GL_ARRAY_BUFFER` target. The second argument specifies the size of the data (in bytes) we want to pass to the buffer; a simple `sizeof` of the vertex data suffices. The third parameter is the actual data we want to send.

The fourth parameter specifies how we want the graphics card to manage the given data. This can take 3 forms:

- `GL_STATIC_DRAW`: the data will most likely not change at all or very rarely.
- `GL_DYNAMIC_DRAW`: the data is likely to change a lot.
- `GL_STREAM_DRAW`: the data will change every time it is drawn.

The position data of the triangle does not change and stays the same for every render call so its usage type should best be `GL_STATIC_DRAW`. If, for instance, one would have a buffer with data that is likely to change frequently, a usage type of `GL_DYNAMIC_DRAW` or `GL_STREAM_DRAW` ensures the graphics card will place the data in memory that allows for faster writes.

As of now we stored the vertex data within memory on the graphics card as managed by a vertex buffer object named `VBO`. Next we want to create a vertex and fragment shader that actually processes this data, so let's start building those.

5.2 Vertex shader

The vertex shader is one of the shaders that are programmable by people like us. Modern OpenGL requires that we at least set up a vertex and fragment shader if we want to do some rendering so we will briefly introduce shaders and configure two very simple shaders for drawing our first triangle. In the next tutorial we'll discuss shaders in more detail.

The first thing we need to do is write the vertex shader in the shader language GLSL (OpenGL Shading Language) and then compile this shader so we can use it in our application. Below you'll find the source code of a very basic vertex shader in GLSL:

```
#version 330 core

layout (location = 0) in vec3 position;
```

```
void main()
{
    gl_Position = vec4(position.x, position.y, position.z, 1.0);
}
```

As you can see, GLSL looks similar to C. Each shader begins with a declaration of its version. Since OpenGL 3.3 and higher the version numbers of GLSL match the version of OpenGL (GLSL version 420 corresponds to OpenGL version 4.2 for example). We also explicitly mention we're using core profile functionality.

Next we declare all the input vertex attributes in the vertex shader with the `in` keyword. Right now we only care about position data so we only need a single vertex attribute. GLSL has a vector datatype that contains 1 to 4 floats based on its postfix digit. Since each vertex has a 3D coordinate we create a `vec3` input variable with the name `position`. We also specifically set the location of the input variable via `layout (location = 0)` and you'll later see that why we're going to need that location.

Vector

In graphics programming we use the mathematical concept of a vector quite often, since it neatly represents positions/directions in any space and has useful mathematical properties. A vector in GLSL has a maximum size of 4 and each of its values can be retrieved via `vec.x`, `vec.y`, `vec.z` and `vec.w` respectively where each of them represents a coordinate in space. Note that the `vec.w` component is not used as a position in space (we're dealing with 3D, not 4D) but is used for something called *perspective division*. We'll discuss vectors in much greater depth in a later tutorial.

To set the output of the vertex shader we have to assign the position data to the predefined `gl_Position` variable which is a `vec4` behind the scenes. At the end of the `main` function, whatever we set `gl_Position` to will be used as the output of the vertex shader. Since our input is a vector of size 3 we have to cast this to a vector of size 4. We can do this by inserting the `vec3` values inside the constructor of `vec4` and set its `w` component to `1.0f` (we will explain why in a later tutorial).

The current vertex shader is probably the most simple vertex shader we can imagine because we did no processing whatsoever on the input data and simply forwarded it to the shader's output. In real applications the input data is usually not already in normalized device coordinates so we first have to transform the input data to coordinates that fall within OpenGL's visible region

5.3 Compiling a shader

We wrote the source code for the vertex shader, but in order for OpenGL to use the shader it has to dynamically compile it at run-time from its source code.

The first thing we need to do is create a shader object, again referenced by an ID. So we store the vertex shader as a `GLuint` and create the shader with `glCreateShader`:

```
GLuint vertexShader;
vertexShader = glCreateShader(GL_VERTEX_SHADER);
```

We provide the type of shader we want to create as an argument to `glCreateShader`. Since we're creating a vertex shader we pass in `GL_VERTEX_SHADER`.

Next we attach the shader source code to the shader object and compile the shader:

```
glShaderSource(vertexShader, 1, &vertexShaderSource, NULL);
glCompileShader(vertexShader);
```

The `glShaderSource` function takes the shader object to compile to as its first argument. The second argument specifies how many strings we're passing as source code, which is only one. The third parameter is the actual source code of the vertex shader and we can leave the 4th parameter to `NULL`.

You probably want to check if compilation was successful after the call to `glCompileShader` and if not, what errors were found so you can fix those. Checking for compile-time errors is accomplished as follows:

```
GLint success;
GLchar infoLog[512];
glGetShaderiv(vertexShader, GL_COMPILE_STATUS, &success);
```

First we define an integer to indicate success and a storage container for the error messages (if any). Then we check if compilation was successful with `glGetShaderiv`. If compilation failed, we should retrieve the error message with `glGetShaderInfoLog` and print the error message.

```
if (!success)
{
    glGetShaderInfoLog(vertexShader, 512, NULL, infoLog);
    std::cout << "ERROR::SHADER::VERTEX::COMPILATION_FAILED\n" <<
    infoLog << std::endl;
}
```

If no errors were detected while compiling the vertex shader it is now compiled.

5.4 Fragment shader

The fragment shader is the second and final shader we're going to create for rendering a triangle. The fragment shader is all about calculating the color output of your pixels. To keep things simple the fragment shader will always output an orange-ish color.

Colors in computer graphics are represented as an array of 4 values: the red, green, blue and alpha (opacity) component, commonly abbreviated to RGBA. When defining a color in OpenGL or GLSL we set the strength of each component to a value between 0.0 and 1.0. If, for example, we would set red to 1.0f and green to 1.0f we would get a mixture of both colors and get the color yellow. Given those 3 color components we can generate over 16 million different colors!

```
#version 330 core

out vec4 color;

void main()
{
    color = vec4(1.0f, 0.5f, 0.2f, 1.0f);
}
```

The fragment shader only requires one output variable and that is a vector of size 4 that defines the final color output that we should calculate ourselves. We can declare output values with the `out` keyword, that we here promptly named `color`. Next we simply assign a `vec4` to the color output as an orange color with an alpha value of 1.0 (1.0 being completely opaque).

The process for compiling a fragment shader is similar to the vertex shader, although this time we use the `GL_FRAGMENT_SHADER` constant as the shader type:

```
GLuint fragmentShader;
fragmentShader = glCreateShader(GL_FRAGMENT_SHADER);
glShaderSource(fragmentShader, 1, &fragmentShaderSource, NULL);
glCompileShader(fragmentShader);
```

Both the shaders are now compiled and the only thing left to do is link both shader objects into a **shader program** that we can use for rendering.

5.4.1 Shader program

A shader program object is the final linked version of multiple shaders combined. To use the recently compiled shaders we have to **link** them to a shader program object and then activate this shader program when rendering objects. The activated shader program's shaders will be used when we issue render calls.

When linking the shaders into a program it links the outputs of each shader to the inputs of the next shader. This is also where you'll get linking errors if your outputs and inputs do not match.

Creating a program object is easy:

```
GLuint shaderProgram;
shaderProgram = glCreateProgram();
```

The `glCreateProgram` function creates a program and returns the ID reference to the newly created program object. Now we need to attach the previously compiled shaders to the program object and then link them with `glLinkProgram`:

```
glAttachShader(shaderProgram, vertexShader);
glAttachShader(shaderProgram, fragmentShader);
glLinkProgram(shaderProgram);
```

The code should be pretty self-explanatory, we attach the shaders to the program and link them via `glLinkProgram`.

Just like shader compilation we can also check if linking a shader program failed and retrieve the corresponding log. However, instead of using `glGetShaderiv` and `glGetShaderInfoLog` we now use:

```
glGetProgramiv(shaderProgram, GL_LINK_STATUS, &success);
if(!success) {
    glGetProgramInfoLog(shaderProgram, 512, NULL, infoLog);
    ...
}
```

The result is a program object that we can activate by calling `glUseProgram` with the newly created program object as its argument:

```
glUseProgram(shaderProgram);
```

Every shader and rendering call after `glUseProgram` will now use this program object (and thus the shaders).

Oh yeah, and don't forget to delete the shader objects once we've linked them into the program object; we no longer need them anymore:

```
glDeleteShader(vertexShader);
glDeleteShader(fragmentShader);
```

Right now we sent the input vertex data to the GPU and instructed the GPU how it should process the vertex data within a vertex and fragment shader. We're almost there, but not quite yet. OpenGL does not yet know how it should interpret the vertex data in memory and how it should connect the vertex data to the vertex shader's attributes. We'll be nice and tell OpenGL how to do that.

5.5 Linking Vertex Attributes

The vertex shader allows us to specify any input we want in the form of vertex attributes and while this allows for great flexibility, it does mean we have to manually specify what part of our input data goes to which vertex attribute in the vertex shader. This means we have to specify how OpenGL should interpret the vertex data before rendering.

Our vertex buffer data is formatted as follows:

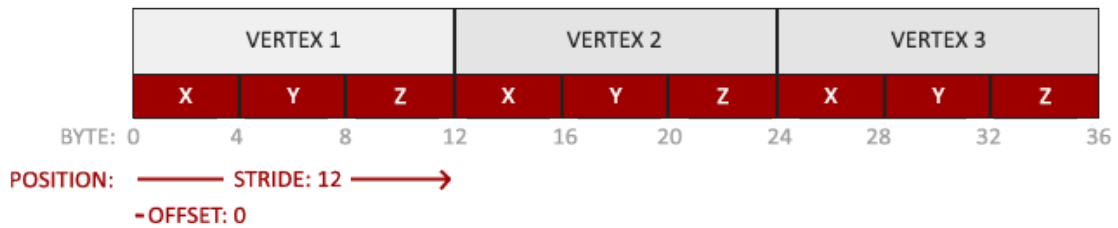

- The position data is stored as 32-bit (4 byte) floating point values.
- Each position is composed of 3 of those values.
- There is no space (or other values) between each set of 3 values. The values are **tightly packed** in the array.
- The first value in the data is at the beginning of the buffer.

With this knowledge we can tell OpenGL how it should interpret the vertex data (per vertex attribute) using `glVertexAttribPointer`:

```
glVertexAttribPointer(0, 3, GL_FLOAT, GL_FALSE, 3 * sizeof(GLfloat), (
    GLvoid*) 0);
glEnableVertexAttribArray(0);
```

The function `glVertexAttribPointer` has quite a few parameters so let's carefully walk through them:

- The first parameter specifies which vertex attribute we want to configure. Remember that we specified the location of the `position` vertex attribute in the vertex shader with `layout (location = 0)`. This sets the location of the vertex attribute to 0 and since we want to pass data to this vertex attribute, we pass in 0.
- The next argument specifies the size of the vertex attribute. The vertex attribute is a `vec3` so it is composed of 3 values.
- The third argument specifies the type of the data which is `GL_FLOAT` (a `vec*` in GLSL consists of floating point values).
- The next argument specifies if we want the data to be normalized. If we set this to `GL_TRUE` all the data that has a value not between 0 (or -1 for signed data) and 1 will be mapped to those values. We leave this at `GL_FALSE`.
- The fifth argument is known as the **stride** and tells us the space between consecutive vertex attribute sets. Since the next set of position data is located exactly 3 times the size of a `GLfloat` away we specify that value as the stride. Note that since we know that the array is tightly packed (there is no space between the next vertex attribute value) we could've also specified the stride as 0 to let OpenGL determine the stride (this only works when values are tightly packed). Whenever we have more vertex attributes we have to carefully define the spacing between each vertex attribute but we'll get to see more examples of that later on.
- The last parameter is of type `GLvoid*` and thus requires that weird cast. This is the **offset** of where the position data begins in the buffer. Since the position data is at the start of the data array this value is just 0. We will explore this parameter in more detail later on

Each vertex attribute takes its data from memory managed by a VBO and which VBO it takes its data from (one could have multiple VBOs) is determined by the VBO currently bound to `GL_ARRAY_BUFFER` when calling `glVertexAttribPointer`. Since the previously defined VBO was bound before calling `glVertexAttribPointer` vertex attribute 0 is now associated with its vertex data.

Now that we specified how OpenGL should interpret the vertex data we should also enable the vertex attribute with `glEnableVertexAttribArray` giving the vertex attribute location as its argument; vertex attributes are disabled by default. From that point on we have everything set up: we initialized the vertex data in a buffer using a vertex buffer object, set up a vertex and fragment shader and told OpenGL how to link the vertex data to the vertex shader's vertex attributes. Drawing an object in OpenGL would now look something like this:

```
// 0. Copy our vertices array in a buffer for OpenGL to use
glBindBuffer(GL_ARRAY_BUFFER, VBO);
glBufferData(GL_ARRAY_BUFFER, sizeof(vertices), vertices, GL_STATIC_DRAW);
// 1. Then set the vertex attributes pointers
glVertexAttribPointer(0, 3, GL_FLOAT, GL_FALSE, 3 * sizeof(GLfloat), (
    GLvoid*)0);
glEnableVertexAttribArray(0);
// 2. Use our shader program when we want to render an object
glUseProgram(shaderProgram);
// 3. Now draw the object
someOpenGLFunctionThatDrawsOurTriangle();
```

We have to repeat this process every time we want to draw an object. It may not look like that much, but imagine if we have over 5 vertex attributes and perhaps 100s of different objects (which is not uncommon). Binding the appropriate buffer objects and configuring all vertex attributes for each of those objects quickly becomes a cumbersome process. What if there was some way we could store all these state configurations into an object and simply bind this object to restore its state?

5.5.1 Vertex Array Object

A **vertex array object** (also known as **VAO**) can be bound just like a vertex buffer object and any subsequent vertex attribute calls from that point on will be stored inside the VAO. This has the advantage that when configuring vertex attribute pointers you only have to make those calls once and whenever we want to draw the object, we can just bind the corresponding VAO. This makes switching between different vertex data and attribute configurations as easy as binding a different VAO. All the state we just set is stored inside the VAO.

Core OpenGL **requires** that we use a VAO so it knows what to do with our vertex inputs. If we fail to bind a VAO, OpenGL will most likely refuse to draw anything.

A vertex array object stores the following:

- Calls to `glEnableVertexAttribArray` or `glDisableVertexAttribArray`.
- Vertex attribute configurations via `glVertexAttribPointer`.
- Vertex buffer objects associated with vertex attributes by calls to `glVertexAttribPointer`.

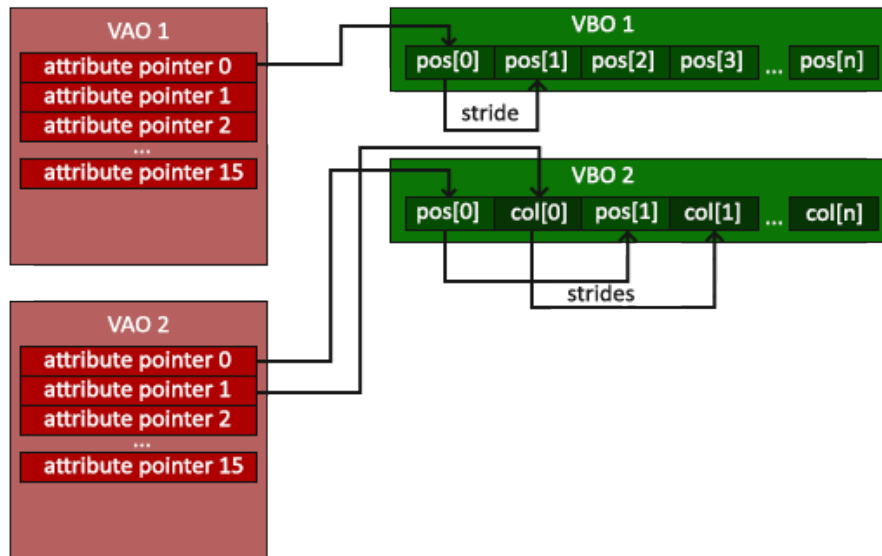

The process to generate a VAO looks similar to that of a VBO:

```
GLuint VAO;
glGenVertexArrays(1, &VAO);
```

To use a VAO all you have to do is bind the VAO using `glBindVertexArray`. From that point on we should bind/configure the corresponding VBO(s) and attribute pointer(s) and then unbind the VAO for later use. As soon as we want to draw an object, we simply bind the VAO with the preferred settings before drawing the object and that is it. In code this would look a bit like this:

```
// ...: Initialization code (done once (unless your object frequently
// changes)) :: ..
// 1. Bind Vertex Array Object
glBindVertexArray(VAO);
// 2. Copy our vertices array in a buffer for OpenGL to use
glBindBuffer(GL_ARRAY_BUFFER, VBO);
glBufferData(GL_ARRAY_BUFFER, sizeof(vertices), vertices,
GL_STATIC_DRAW);
// 3. Then set our vertex attributes pointers
glVertexAttribPointer(0, 3, GL_FLOAT, GL_FALSE, 3 * sizeof(GLfloat), (
GLvoid*)0);
glEnableVertexAttribArray(0);
//4. Unbind the VAO
glBindVertexArray(0);

[...]

// ...: Drawing code (in Game loop) :: ..
// 5. Draw the object
glUseProgram(shaderProgram);
glBindVertexArray(VAO);
someOpenGLFunctionThatDrawsOurTriangle();
glBindVertexArray(0);
```

It is common practice to unbind OpenGL objects when we're done configuring them so we don't mistakenly (mis)configure them elsewhere.

And that is it! Everything we did the last few million pages led up to this moment, a VAO that stores our vertex attribute configuration and which VBO to use. Usually when you have multiple objects you want to draw, you first generate/configure all the VAOs (and thus the required VBO and attribute pointers) and store those for later use. The moment we want to draw one of our objects, we take the corresponding VAO, bind it, then draw the object and unbind the VAO again.

5.5.2 The triangle we've all been waiting for

To draw our objects of choice OpenGL provides us with the `glDrawArrays` function that draws primitives using the currently active shader, the previously defined vertex attribute configuration and with the VBO's vertex data (indirectly bound via the VAO).

```
glUseProgram(shaderProgram);  
glBindVertexArray(VAO);  
glDrawArrays(GL_TRIANGLES, 0, 3);  
glBindVertexArray(0);
```

The `glDrawArrays` function takes as its first argument the OpenGL primitive type we would like to draw. Since we said at the start we wanted to draw a triangle and I don't like lying to you, we pass in `GL_TRIANGLES`. The second argument specifies the starting index of the vertex array we'd like to draw; we just leave this at 0. The last argument specifies how many vertices we want to draw, which is 3 (we only render 1 triangle from our data, which is exactly 3 vertices long).

Now try to compile the code and work your way backwards if any errors popped up. As soon as your application compiles, you should see the following result:

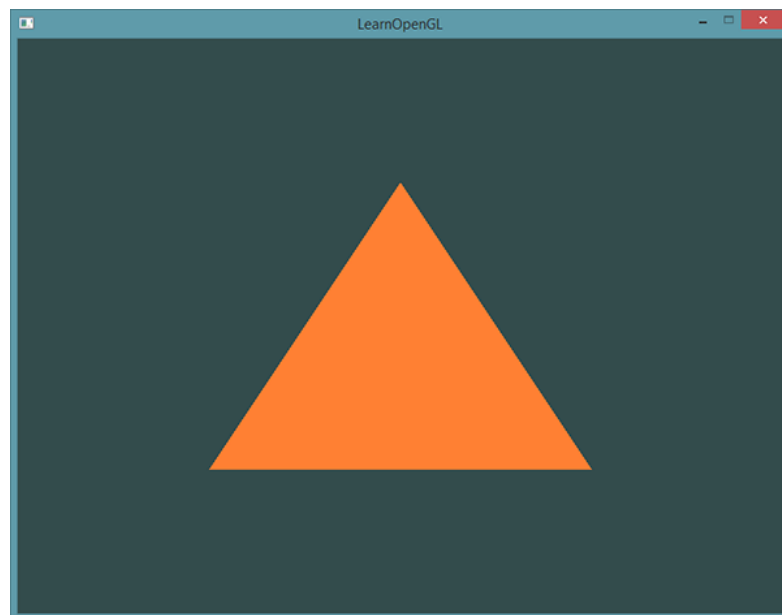

The source code for the complete program can be found [here](#).

If your output does not look the same you probably did something wrong along the way so

check the complete source code, see if you missed anything or ask below in the comments section.

5.6 Element Buffer Objects

There is one last thing we'd like to discuss when rendering vertices and that is **element buffer objects** abbreviated to EBO. To explain how element buffer objects work it's best to give an example: suppose we want to draw a rectangle instead of a triangle. We can draw a rectangle using two triangles (OpenGL mainly works with triangles). This will generate the following set of vertices:

```
GLfloat vertices[] = {
    // First triangle
    0.5f, 0.5f, 0.0f, // Top Right
    0.5f, -0.5f, 0.0f, // Bottom Right
    -0.5f, 0.5f, 0.0f, // Top Left
    // Second triangle
    0.5f, -0.5f, 0.0f, // Bottom Right
    -0.5f, -0.5f, 0.0f, // Bottom Left
    -0.5f, 0.5f, 0.0f // Top Left
};
```

As you can see, there is some overlap on the vertices specified. We specify `Bottom Right` and `Top Left` twice! This is an overhead of 50% since the same rectangle could also be specified with only 4 vertices, instead of 6. This will only get worse as soon as we have more complex models that have over 1000s of triangles where there will be large chunks that overlap. What would be a better solution is to store only the unique vertices and then specify the order at which we want to draw these vertices in. In that case we would only have to store 4 vertices for the rectangle, and then just specify at which order we'd like to draw them. Wouldn't it be great if OpenGL provided us with a feature like that?

Thankfully, element buffer objects work exactly like that. An EBO is a buffer, just like a vertex buffer object, that stores indices that OpenGL uses to decide what vertices to draw. This so called **indexed drawing** is exactly the solution to our problem. To get started we first have to specify the (unique) vertices and the indices to draw them as a rectangle:

```
GLfloat vertices[] = {
    0.5f, 0.5f, 0.0f, // Top Right
    0.5f, -0.5f, 0.0f, // Bottom Right
    -0.5f, -0.5f, 0.0f, // Bottom Left
    -0.5f, 0.5f, 0.0f // Top Left
};
GLuint indices[] = { // Note that we start from 0!
    0, 1, 3, // First Triangle
    1, 2, 3 // Second Triangle
};
```

You can see that, when using indices, we only need 4 vertices instead of 6. Next we need to create the element buffer object:

```
GLuint EBO;
glGenBuffers(1, &EBO);
```

Similar to the VBO we bind the EBO and copy the indices into the buffer with `glBufferData`. Also, just like the VBO we want to place those calls between a bind and an unbind call, although this time we specify `GL_ELEMENT_ARRAY_BUFFER` as the buffer type.

```
glBindBuffer(GL_ELEMENT_ARRAY_BUFFER, EBO);
glBufferData(GL_ELEMENT_ARRAY_BUFFER, sizeof(indices), indices,
             GL_STATIC_DRAW);
```

Note that we're now giving `GL_ELEMENT_ARRAY_BUFFER` as the buffer target. The last thing left to do is replace the `glDrawArrays` call with `glDrawElements` to indicate we want to render the triangles from an index buffer. When using `glDrawElements` we're going to draw using indices provided in the element buffer object currently bound:

```
glBindBuffer(GL_ELEMENT_ARRAY_BUFFER, EBO);
glDrawElements(GL_TRIANGLES, 6, GL_UNSIGNED_INT, 0);
```

The first argument specifies the mode we want to draw in, similar to `glDrawArrays`. The second argument is the count or number of elements we'd like to draw. We specified 6 indices so we want to draw 6 vertices in total. The third argument is the type of the indices which is of type `GL_UNSIGNED_INT`. The last argument allows us to specify an offset in the EBO (or pass in an index array, but that is when you're not using element buffer objects), but we're just going to leave this at 0.

The `glDrawElements` function takes its indices from the EBO currently bound to the `GL_ELEMENT_ARRAY_BUFFER` target. This means we have to bind the corresponding EBO each time we want to render an object with indices which seems again a bit cumbersome. It just so happens that a vertex array object also keeps track of element buffer object bindings. The element buffer object currently bound while a VAO is bound, is stored as the VAO's element buffer object. Binding to a VAO thus also automatically binds its EBO.

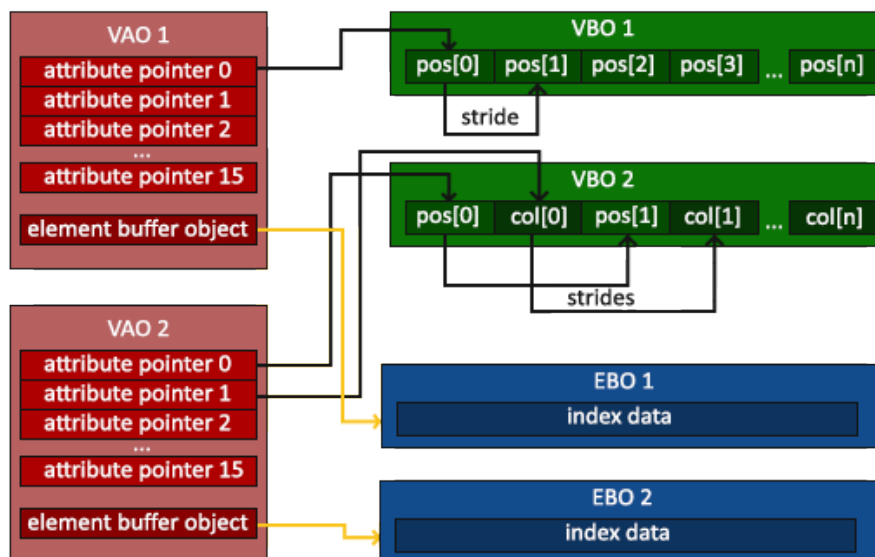

A VAO stores the `glBindBuffer` calls when the target is `GL_ELEMENT_ARRAY_BUFFER`. This also means it stores its unbind calls so make sure you don't unbind the element array buffer before unbinding your VAO, otherwise it doesn't have an EBO configured.

The resulting initialization and drawing code now looks something like this:

```
// ...: Initialization code :: ..
// 1. Bind Vertex Array Object
glBindVertexArray(VAO);
// 2. Copy our vertices array in a vertex buffer for OpenGL to use
glBindBuffer(GL_ARRAY_BUFFER, VBO);
glBufferData(GL_ARRAY_BUFFER, sizeof(vertices), vertices,
GL_STATIC_DRAW);
// 3. Copy our index array in a element buffer for OpenGL to use
glBindBuffer(GL_ELEMENT_ARRAY_BUFFER, EBO);
glBufferData(GL_ELEMENT_ARRAY_BUFFER, sizeof(indices), indices,
GL_STATIC_DRAW);
// 3. Then set the vertex attributes pointers
glVertexAttribPointer(0, 3, GL_FLOAT, GL_FALSE, 3 * sizeof(GLfloat), (
GLvoid*)0);
glEnableVertexAttribArray(0);
// 4. Unbind VAO (NOT the EBO)
glBindVertexArray(0);

[...]

// ...: Drawing code (in Game loop) :: ..
glUseProgram(shaderProgram);
glBindVertexArray(VAO);
glDrawElements(GL_TRIANGLES, 6, GL_UNSIGNED_INT, 0)
glBindVertexArray(0);
```

Running the program should give an image as depicted below. The left image should look familiar and the right image is the rectangle drawn in **wireframe mode**. The wireframe rectangle shows that the rectangle indeed consists of two triangles.

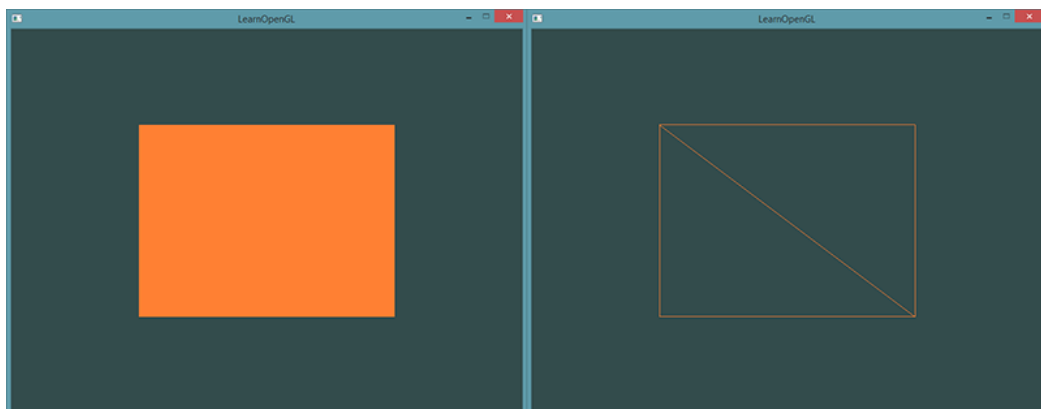

Wireframe mode

To draw your triangles in wireframe mode, you can configure how OpenGL draws its primitives via `glPolygonMode(GL_FRONT_AND_BACK, GL_LINE)`. The first argument says we want to apply it to the front and back of all triangles and the second line tells us to draw them as lines. Any subsequent drawing calls will render the triangles in wireframe mode until we set it back to its default using `glPolygonMode(GL_FRONT_AND_BACK, GL_FILL)`.

If you have any errors, work your way backwards and see if you missed anything. Also, you can find the complete source code [here](#) and feel free to ask any question in the comments section below.

If you managed to draw a triangle or a rectangle just like we did then congratulations, you managed to make it past one of the hardest parts of modern OpenGL: drawing your first triangle. This is a difficult part since there is a large chunk of knowledge required before being able to draw your first triangle. Thankfully, we now made it past that barrier and the upcoming tutorials will hopefully be much easier to understand.

5.7 Additional resources

- antongerdelan.net/hellotriangle: Anton Gerdelan's take on rendering the first triangle.
- open.gl/drawing: Alexander Overvoorde's take on rendering the first triangle.
- antongerdelan.net/vertexbuffers: some extra insights into vertex buffer objects.

5.8 Exercises

To really get a good grasp of the concepts discussed a few exercises were set up. It is advised to work through them before continuing to the next subject to make sure you get a good grasp of what's going on.

1. Try to draw 2 triangles next to each other using `glDrawArrays` by adding more vertices to your data: [solution](#).
2. Now create the same 2 triangles using two different VAOs and VBOs for their data: [solution](#).
3. Create two shader programs where the second program uses a different fragment shader that outputs the color yellow; draw both triangles again where one outputs the color yellow: [solution](#).



6. Shaders

As mentioned in the [Hello Triangle](#) tutorial, shaders are little programs that rest on the GPU. These programs are run for each specific section of the graphics pipeline. In a basic sense, shaders are nothing more than programs transforming inputs to outputs. Shaders are also very isolated programs in that they're not allowed to communicate with each other; the only communication they have is via their inputs and outputs.

In the previous tutorial we briefly touched the surface of shaders and how to properly use them. We will now explain shaders, and specifically the OpenGL Shading Language, in a more general fashion.

6.1 GLSL

Shaders are written in the C-like language GLSL. GLSL is tailored for use with graphics and contains useful features specifically targeted at vector and matrix manipulation.

Shaders always begin with a version declaration, followed by a list of input and output variables, uniforms and its `main` function. Each shader's entry point is at its `main` function where we process any input variables and output the results in its output variables. Don't worry if you don't know what uniforms are, we'll get to those shortly.

A shader typically has the following structure:

```
#version version_number

in type in_variable_name;
in type in_variable_name;

out type out_variable_name;
```

```
uniform type uniform_name;

int main()
{
    // Process input(s) and do some weird graphics stuff
    ...
    // Output processed stuff to output variable
    out_variable_name = weird_stuff_we_processed;
}
```

When we're talking specifically about the vertex shader each input variable is also known as a **vertex attribute**. There is a maximum number of vertex attributes we're allowed to declare limited by the hardware. OpenGL guarantees there are always at least 16 4-component vertex attributes available, but some hardware might allow for more which you can retrieve by querying `GL_MAX_VERTEX_ATTRIBS`:

```
GLint nrAttributes;
glGetIntegerv(GL_MAX_VERTEX_ATTRIBS, &nrAttributes);
std::cout << "Maximum nr of vertex attributes supported: " << nrAttributes
  << std::endl;
```

This often returns the minimum of 16 which should be more than enough for most purposes.

6.2 Types

GLSL has like any other programming language data types for specifying what kind of variable we want to work with. GLSL has most of the default basic types we know from languages like C: `int`, `float`, `double`, `uint` and `bool`. GLSL also features two container types that we'll be using a lot throughout the tutorials, namely `vectors` and `matrices`. We'll discuss matrices in a later tutorial.

6.2.1 Vectors

A vector in GLSL is a 1,2,3 or 4 component container for any of the basic types just mentioned. They can take the following form (`n` represents the number of components):

- `vecn`: the default vector of `n` floats.
- `bvecn`: a vector of `n` booleans.
- `ivecn`: a vector of `n` integers.
- `uvecn`: a vector of `n` unsigned integers.
- `dvecn`: a vector of `n` double components.

Most of the time we will be using the basic `vecn` since floats are sufficient for most of our purposes.

Components of a vector can be accessed via `vec.x` where `x` is the first component of the vector. You can use `.x`, `.y`, `.z` and `.w` to access their first, second, third and fourth component respectively. GLSL also allows you to use `rgba` for colors or `stpq` for texture coordinates, accessing the same components.

The vector datatype allows for some interesting and flexible component selection called **swizzling**. Swizzling allows for the following syntax:

```
vec2 someVec;  
vec4 differentVec = someVec.xyxx;  
vec3 anotherVec = differentVec.zyw;  
vec4 otherVec = someVec.xxxx + anotherVec.yxzy;
```

You can use any combination of up to 4 letters to create a new vector (of the same type) as long as the original vector has those components; it is not allowed to access the `.z` component of a `vec2` for example. We can also pass vectors as arguments to different vector constructor calls, reducing the number of arguments required:

```
vec2 vect = vec2(0.5f, 0.7f);  
vec4 result = vec4(vect, 0.0f, 0.0f);  
vec4 otherResult = vec4(result.xyz, 1.0f);
```

Vectors are thus a flexible datatype that we can use for all kinds of input and output. Throughout the tutorials you'll see plenty of examples of how we can creatively manage vectors.

6.3 Ins and outs

Shaders are nice little programs on their own, but they are part of a whole and for that reason we want to have inputs and outputs on the individual shaders so that we can move stuff around. GLSL defined the `in` and `out` keywords specifically for that purpose. Each shader can specify inputs and outputs using those keywords and wherever an output variable matches with an input variable of the next shader stage they're passed along. The vertex and fragment shader differ a bit though.

The vertex shader should receive some form of input otherwise it would be pretty ineffective. The vertex shader differs in its input, in that it receives its input straight from the vertex data. To define how the vertex data is organized we specify the input variables with location metadata so we can configure the vertex attributes on the CPU. We've seen this in the previous tutorial as `layout (location = 0)`. The vertex shader thus requires an extra layout specification for its inputs so we can link it with the vertex data.

It is also possible to omit the `layout (location = 0)` specifier and query for the attribute locations in your OpenGL code via `glGetAttribLocation`, but I'd prefer to set them in the vertex shader. It is easier to understand and saves you (and OpenGL) some work.

The other exception is that the fragment shader requires a `vec4` color output variable, since the fragment shaders needs to generate a final output color. If you'd fail to specify an output color in your fragment shader OpenGL will render your object black (or white).

So if we want to send data from one shader to the other we'd have to declare an output in the sending shader and a similar input in the receiving shader. When the types and the names are equal on both sides OpenGL will link those variables together and then it is possible to send data between shaders (this is done when linking a program object). To show you how this works in practice we're going to alter the shaders from the previous tutorial to let the vertex shader decide the color for the fragment shader.

Vertex shader

```
#version 330 core
layout (location = 0) in vec3 position; // The position variable has
    attribute position 0

out vec4 vertexColor; // Specify a color output to the fragment shader

void main()
{
    gl_Position = vec4(position, 1.0); // See how we directly give a vec3
    to vec4's constructor
    vertexColor = vec4(0.5f, 0.0f, 0.0f, 1.0f); // Set the output variable
    to a dark-red color
}
```

Fragment shader

```
#version 330 core
in vec4 vertexColor; // The input variable from the vertex shader (same
    name and same type)

out vec4 color;

void main()
{
    color = vertexColor;
}
```

You can see we declared a `vertexColor` variable as a `vec4` output that we set in the vertex shader and we declare a similar `vertexColor` input in the fragment shader. Since they both have the same type and name, the `vertexColor` in the fragment shader is linked to the `vertexColor` in the vertex shader. Because we set the color to a dark-red color in the vertex shader, the resulting fragments should be dark-red as well. The following image shows the output:

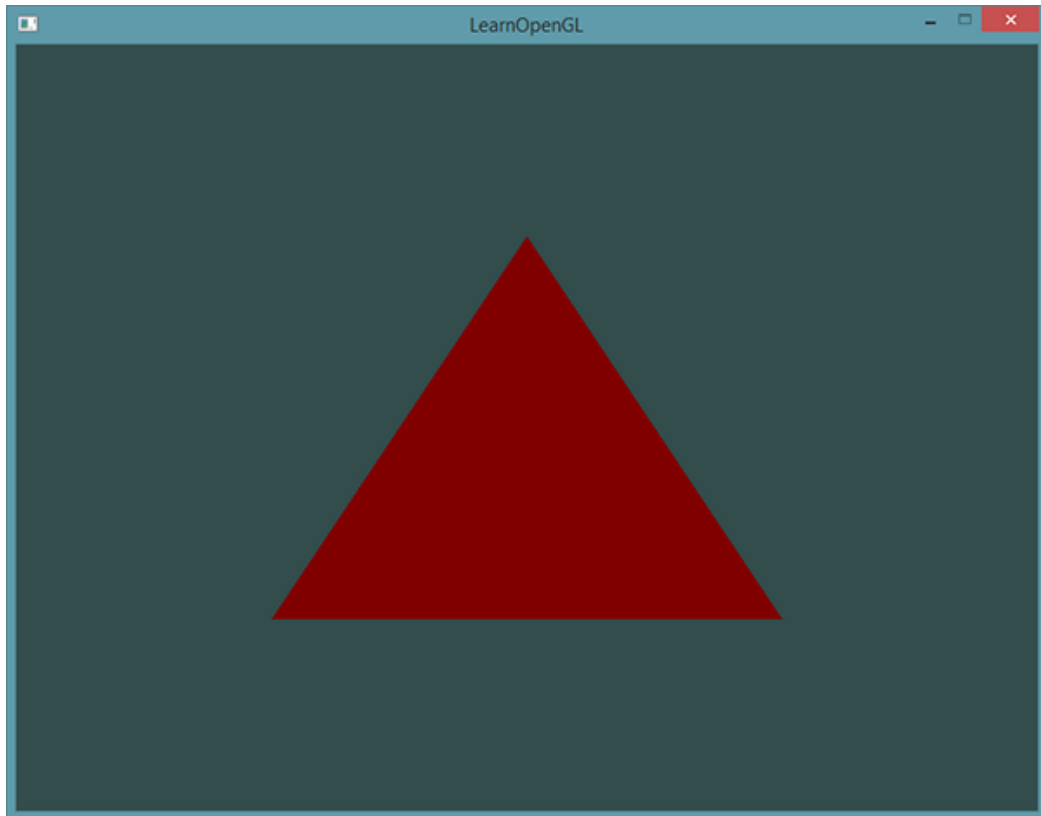

There we go! We just managed to send a value from the vertex shader to the fragment shader. Let's spice it up a bit and see if we can send a color from our application to the fragment shader!

6.4 Uniforms

Uniforms are another way to pass data from our application on the CPU to the shaders on the GPU, but uniforms are slightly different compared to vertex attributes. First of all, uniforms are **global**. Global, meaning that a uniform variable is unique per shader program object, and can be accessed from any shader at any stage in the shader program. Second, whatever you set the uniform value to, uniforms will keep their values until they're either reset or updated.

To declare a uniform in GLSL we simply add the `uniform` keyword to a shader with a type and a name. From that point on we can use the newly declared uniform in the shader. Let's see if this time we can set the color of the triangle via a uniform:

```
#version 330 core

out vec4 color;

uniform vec4 ourColor; // We set this variable in the OpenGL code.

void main()
{
    color = ourColor;
}
```

We declared a uniform `vec4 ourColor` in the fragment shader and set the fragment's output color to the content of this uniform value. Since uniforms are global variables, we can define them in any shader we'd like so no need to go through the vertex shader again to get something to the fragment shader. We're not using this uniform in the vertex shader so there's no need to define it there.

If you declare a uniform that isn't used anywhere in your GLSL code the compiler will silently remove the variable from the compiled version which is the cause for several frustrating errors; keep this in mind!

The uniform is currently empty; we haven't added any data to the uniform yet so let's try that. We first need to find the index/location of the uniform attribute in our shader. Once we have the index/location of the uniform, we can update its values. Instead of passing a single color to the fragment shader, let's spice things up by gradually changing color over time:

```
GLfloat timeValue = glfwGetTime();
GLfloat greenValue = (sin(timeValue) / 2) + 0.5;
GLint vertexColorLocation = glGetUniformLocation(shaderProgram, "ourColor");
;
glUseProgram(shaderProgram);
glUniform4f(vertexColorLocation, 0.0f, greenValue, 0.0f, 1.0f);
```

First, we retrieve the running time in seconds via `glfwGetTime()`. Then we vary the color in the range of `0.0 - 1.0` by using the `sin` function and store the result in `greenValue`.

Then we query for the location of the `ourColor` uniform using `glGetUniformLocation`. We supply the shader program and the name of the uniform (that we want to retrieve the location from) to the query function. If `glGetUniformLocation` returns `-1`, it could not find the location. Lastly we can set the uniform value using the `glUniform4f` function. Note that finding the uniform location does not require you to use the shader program first, but updating a uniform **does** require you to first use the program (by calling `glUseProgram`), because it sets the uniform on the currently active shader program.

Because OpenGL is in its core a C library it does not have native support for type overloading, so wherever a function can be called with different types OpenGL defines new functions for each type required; `glUniform` is a perfect example of this. The function requires a specific postfix for the type of the uniform you want to set. A few of the possible postfixes are:

- `f`: the function expects a `float` as its value
- `i`: the function expects an `int` as its value
- `ui`: the function expects an unsigned `int` as its value
- `3f`: the function expects 3 `floats` as its value
- `fV`: the function expects a `float vector/array` as its value

Whenever you want to configure an option of OpenGL simply pick the overloaded function that corresponds with your type. In our case we want to set 4 floats of the uniform individually so we pass our data via `glUniform4f` (note that we also could've used the `fV` version).

Now that we know how to set the values of uniform variables, we can use them for rendering. If we want the color to gradually change, we want to update this uniform every game loop iteration (so it changes per-frame) otherwise the triangle would maintain a single solid color if we only set it once. So we calculate the `greenValue` and update the uniform each render iteration:

```
while(!glfwWindowShouldClose(window))
{
    // Check and call events
    glfwPollEvents();

    // Render
    // Clear the colorbuffer
    glClearColor(0.2f, 0.3f, 0.3f, 1.0f);
    glClear(GL_COLOR_BUFFER_BIT);

    // Be sure to activate the shader
    glUseProgram(shaderProgram);

    // Update the uniform color
    GLfloat timeValue = glfwGetTime();
    GLfloat greenValue = (sin(timeValue) / 2) + 0.5;
    GLint vertexColorLocation = glGetUniformLocation(shaderProgram, "
ourColor");
    glUniform4f(vertexColorLocation, 0.0f, greenValue, 0.0f, 1.0f);

    // Now draw the triangle
    glBindVertexArray(VAO);
    glDrawArrays(GL_TRIANGLES, 0, 3);
    glBindVertexArray(0);
}
```

The code is a relatively straightforward adaptation of the previous code. This time, we update a uniform value each iteration before drawing the triangle. If you update the uniform correctly you should see the color of your triangle gradually change from green to black and back to green.

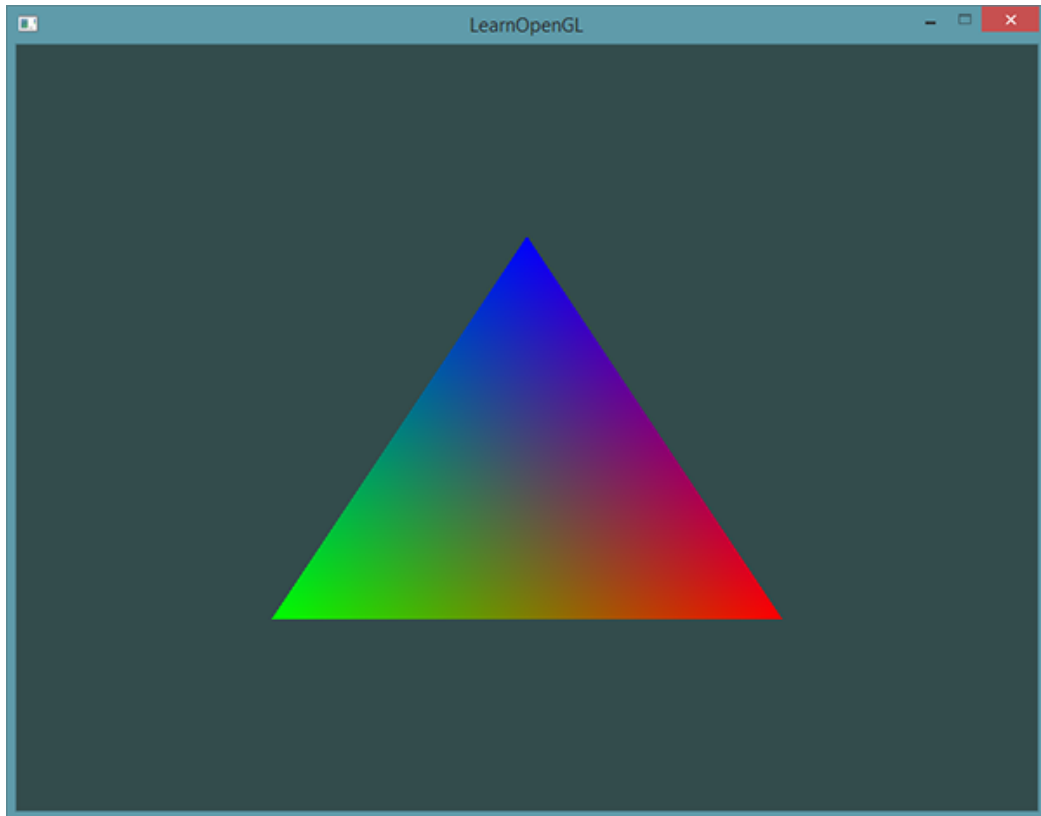

Check out the source code [here](#) if you're stuck.

The image might not be exactly what you would expect, since we only supplied 3 colors, not the huge color palette we're seeing right now. This is all the result of something called **fragment interpolation** in the fragment shader. When rendering a triangle the rasterization stage usually results in a lot more fragments than vertices originally specified. The rasterizer then determines the positions of each of those fragments based on where they reside on the triangle shape.

Based on these positions, it **interpolates** all the fragment shader's input variables. Say for example we have a line where the upper point has a green color and the lower point a blue color. If the fragment shader is run at a fragment that resides around a position at 70% of the line its resulting color input attribute would then be a linear combination of green and blue; to be more precise: 30% blue and 70% green.

This is exactly what happened at the triangle. We have 3 vertices and thus 3 colors and judging from the triangle's pixels it probably contains around 50000 fragments, where the fragment shader interpolated the colors among those pixels. If you take a good look at the colors you'll see it all makes sense: red to blue first gets to purple and then to blue. Fragment interpolation is applied to all the fragment shader's input attributes.

6.5 Our own shader class

Writing, compiling and managing shaders can be quite cumbersome. As a final touch on the shader subject we're going to make our life a bit easier by building a shader class that reads shaders from disk, compiles and links them, checks for errors and is easy to use. This also gives you a bit of an idea how we can encapsulate some of the knowledge we learned so far into useful abstract objects.

We will create the shader class entirely in a header file, mainly for learning purposes and portability. Let's start by adding the required includes and by defining the class structure:

```
#ifndef SHADER_H
#define SHADER_H

#include <string>
#include <fstream>
#include <sstream>
#include <iostream>
using namespace std;

#include <GL/glew.h>; // Include glew to get all the required OpenGL
                    headers

class Shader
{
public:
    // The program ID
    GLuint Program;
    // Constructor reads and builds the shader
    Shader(const GLchar* vertexSourcePath, const GLchar* fragmentSourcePath
    );
    // Use the program
    void Use();
};

#endif
```

We used several **preprocessor directives** at the top of the header file. Using these little lines of code informs your compiler to only include and compile this header file if it hasn't been included yet, even if multiple files include the shader header. This prevents linking conflicts.

The shader class holds the ID of the shader program. Its constructor requires the file paths of the source code of the vertex and fragment shader respectively that we can store on disk as simple text files. To add a little extra we also added a utility `Use` function which is rather trivial, but a nice display of how we could ease our life (albeit a little) with home-made classes.

6.6 Reading from file

We're using C++ filestreams to read the content from the file into several `string` objects:

```
Shader(const GLchar* vertexPath, const GLchar* fragmentPath)
{
    // 1. Retrieve the vertex/fragment source code from filePath
    std::string vertexCode;
    std::string fragmentCode;
    std::ifstream vShaderFile;
    std::ifstream fShaderFile;
    // ensures ifstream objects can throw exceptions:
    vShaderFile.exceptions (std::ifstream::failbit | std::ifstream::badbit)
;
}
```

```

fShaderFile.exceptions (std::ifstream::failbit | std::ifstream::badbit)
;
try
{
    // Open files
    vShaderFile.open(vertexPath);
    fShaderFile.open(fragmentPath);
    std::stringstream vShaderStream, fShaderStream;
    // Read file's buffer contents into streams
    vShaderStream << vShaderFile.rdbuf();
    fShaderStream << fShaderFile.rdbuf();
    // close file handlers
    vShaderFile.close();
    fShaderFile.close();
    // Convert stream into GLchar array
    vertexCode = vShaderStream.str();
    fragmentCode = fShaderStream.str();
}
catch(std::ifstream::failure e)
{
    std::cout << "ERROR::SHADER::FILE_NOT_SUCCESFULLY_READ" << std:::
endl;
}
const GLchar* vShaderCode = vertexCode.c_str();
const GLchar* fShaderCode = fragmentCode.c_str();
[...]
```

Next we need to compile and link the shaders. Note that we're also reviewing if compilation/linking failed and if so, print the compile-time errors which is extremely useful when debugging (you are going to need those error logs eventually):

```

// 2. Compile shaders
GLuint vertex, fragment;
GLint success;
GLchar infoLog[512];

// Vertex Shader
vertex = glCreateShader(GL_VERTEX_SHADER);
glShaderSource(vertex, 1, &vShaderCode, NULL);
glCompileShader(vertex);
// Print compile errors if any
glGetShaderiv(vertex, GL_COMPILE_STATUS, &success);
if(!success)
{
    glGetShaderInfoLog(vertex, 512, NULL, infoLog);
    std::cout << "ERROR::SHADER::VERTEX::COMPILATION_FAILED\n" << infoLog
<< std::endl;
};

// Similiar for Fragment Shader
[...]
```

```

// Shader Program
this->Program = glCreateProgram();
glAttachShader(this->Program, vertex);
glAttachShader(this->Program, fragment);
glLinkProgram(this->Program);
// Print linking errors if any
glGetProgramiv(this->Program, GL_LINK_STATUS, &success);
if(!success)
```

```

{
    glGetProgramInfoLog(this->Program, 512, NULL, infoLog);
    std::cout << "ERROR::SHADER::PROGRAM::LINKING_FAILED\n" << infoLog <<
    std::endl;
}

// Delete the shaders as they're linked into our program now and no longer
// necessary
glDeleteShader(vertex);
glDeleteShader(fragment);

```

And as a finishing touch we will also implement the `Use` function:

```
void Use() { glUseProgram(this->Program); }
```

And there we have it, a completed shader class. Using the shader class is fairly easy; we create a shader object once and from that point on simply start using it:

```

Shader ourShader("path/to/shaders/shader.vs", "path/to/shaders/shader.frag"
);
...
while(...)
{
    ourShader.Use();
    glUniform1f(glGetUniformLocation(ourShader.Program, "someUniform"), 1.0f);
    DrawStuff();
}

```

Here we stored the vertex and fragment shader source code in two files called `shader.vs` and `shader.frag`. You're free to name your shader files in any way you like; I personally find the extensions `.vs` and `.frag` quite intuitive.

Source code of the [program with new shader class](#), the [shader class](#), the [vertex shader](#) and the [fragment shader](#).

6.7 Exercises

1. Adjust the vertex shader so that the triangle is upside down: [solution](#).
2. Specify a horizontal offset via a uniform and move the triangle to the right side of the screen in the vertex shader using this offset value: [solution](#).
3. Output the vertex position to the fragment shader using the `out` keyword and set the fragment's color equal to this vertex position (see how even the vertex position values are interpolated across the triangle). Once you managed to do this; try to answer the following question: why is the bottom-left side of our triangle black?: [solution](#).

A futuristic cityscape with a flying vehicle. The scene is set in a dense, vertical city with many tall, thin buildings. A flying vehicle with blue lights is in the foreground, flying towards the right. The background is a hazy, distant cityscape.

7. Textures

We learned that to add more detail to our objects we can use colors for each vertex to create some interesting images. However, to get a fair bit of realism we'd have to have many vertices so we could specify a lot of colors. This takes up a considerable amount of extra overhead, since each model needs a lot more vertices and for each vertex a color attribute as well.

What artists and programmers generally prefer is to use a [texture](#). A texture is a 2D image (even 1D and 3D textures exist) used to add detail to an object; think of a texture as a piece of paper with a nice brick image (for example) on it neatly folded over your 3D house so it looks like your house has a stone exterior. Because we can insert a lot of detail in a single image, we can give the illusion the object is extremely detailed without having to specify extra vertices.

Aside from images, textures can also be used to store a large collection of data to send to the shaders, but we'll leave that for a different topic.

Below you'll see a texture image of a [brick wall](#) mapped to the triangle from the previous tutorial.

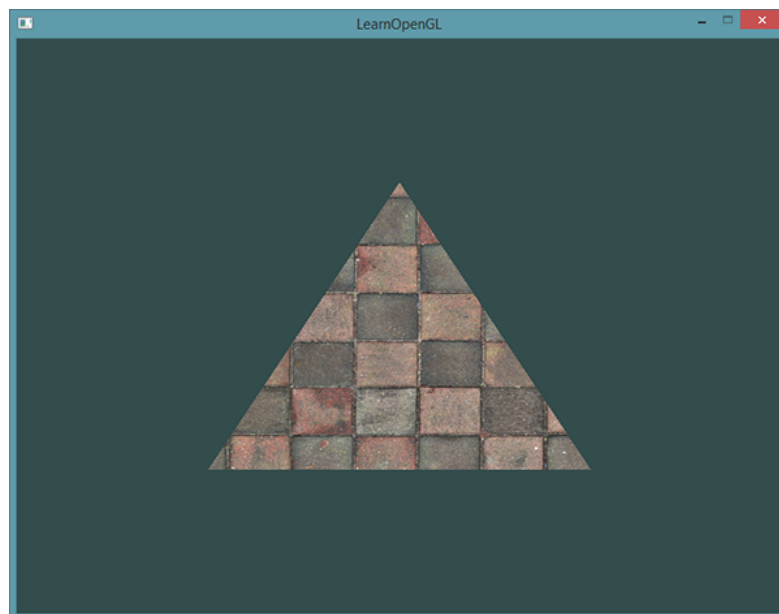

In order to map a texture to the triangle we need to tell each vertex of the triangle which part of the texture it corresponds to. Each vertex should thus have a **texture coordinate** associated with them that specifies what part of the texture image to sample from. Fragment interpolation then does the rest for the other fragments.

Texture coordinates range from 0 to 1 in the x and y axis (remember that we use 2D texture images). Retrieving the texture color using texture coordinates is called **sampling**. Texture coordinates start at $(0, 0)$ for the lower left corner of a texture image to $(1, 1)$ for the upper right corner of a texture image. The following image shows how we map texture coordinates to the triangle:

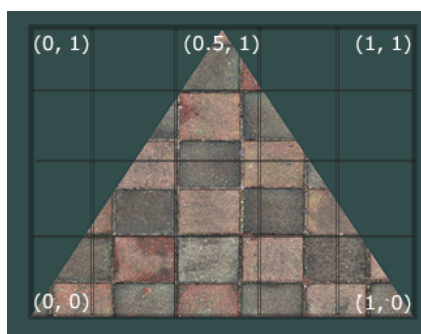

We specify 3 texture coordinate points for the triangle. We want the bottom-left side of the triangle to correspond with the bottom-left side of the texture so we use the $(0, 0)$ texture coordinate for the triangle's bottom-left vertex. The same applies to the bottom-right side with a $(1, 0)$ texture coordinate. The top of the triangle should correspond with the top-center of the texture image so we take $(0.5, 1.0)$ as its texture coordinate. We only have to pass 3 texture coordinates to the vertex shader, which then passes those to the fragment shader that neatly interpolates all the texture coordinates for each fragment.

The resulting texture coordinates would then look like this:

```
GLfloat texCoords[] = {
```

```

0.0f, 0.0f, // Lower-left corner
1.0f, 0.0f, // Lower-right corner
0.5f, 1.0f // Top-center corner
};

```

Texture sampling has a loose interpretation and can be done in many different ways. It is thus our job to tell OpenGL how it should *sample* its textures.

7.1 Texture Wrapping

Texture coordinates usually range from $(0, 0)$ to $(1, 1)$ but what happens if we specify coordinates outside this range? The default behavior of OpenGL is to repeat the texture images (we basically ignore the integer part of the floating point texture coordinate), but there are more options OpenGL offers:

- `GL_REPEAT`: The default behavior for textures. Repeats the texture image.
- `GL_MIRRORED_REPEAT`: Same as `GL_REPEAT` but mirrors the image with each repeat.
- `GL_CLAMP_TO_EDGE`: Clamps the coordinates between 0 and 1. The result is that higher coordinates become clamped to the edge, resulting in a stretched edge pattern.
- `GL_CLAMP_TO_BORDER`: Coordinates outside the range are now given a user-specified border color.

Each of the options have a different visual output when using texture coordinates outside the default range. Let's see what these look like on a sample texture image:



Each of the aforementioned options can be set per coordinate axis (*s*, *t* (and *r* if you're using 3D textures) equivalent to *x*, *y*, *z*) with the `glTexParameter*` function:

```

glTexParameteri(GL_TEXTURE_2D, GL_TEXTURE_WRAP_S, GL_MIRRORED_REPEAT);
glTexParameteri(GL_TEXTURE_2D, GL_TEXTURE_WRAP_T, GL_MIRRORED_REPEAT);

```

The first argument specifies the texture target; we're working with 2D textures so the texture target is `GL_TEXTURE_2D`. The second argument requires us to tell what option we want to set and for which texture axis. We want to configure the `WRAP` option and specify it for both the *S* and *T* axis. The last argument requires us to pass in the texture wrapping mode we'd like and in this case OpenGL will set its texture wrapping option on the currently active texture with `GL_MIRRORED_REPEAT`.

If we choose the `GL_CLAMP_TO_BORDER` option we should also specify a border color. This is done using the `fV` equivalent of the `glTexParameter` function with `GL_TEXTURE_BORDER_COLOR` as its option where we pass in a float array of the border's color value:

```
float borderColor[] = { 1.0f, 1.0f, 0.0f, 1.0f };
glTexParameterfv(GL_TEXTURE_2D, GL_TEXTURE_BORDER_COLOR, borderColor);
```

7.2 Texture Filtering

Texture coordinates do not depend on resolution but can be any floating point value, thus OpenGL has to figure out which texture pixel (also known as a **texel**) to map the texture coordinate to. This becomes especially important if you have a very large object and a low resolution texture. You probably guessed by now that OpenGL has options for this **texture filtering** as well. There are several options available but for now we'll discuss the most important options: `GL_NEAREST` and `GL_LINEAR`.

`GL_NEAREST` (also known as **nearest neighbor filtering**) is the default texture filtering method of OpenGL. When set to `GL_NEAREST`, OpenGL selects the pixel which center is closest to the texture coordinate. Below you can see 4 pixels where the cross represents the exact texture coordinate. The upper-left texel has its center closest to the texture coordinate and is therefore chosen as the sampled color:

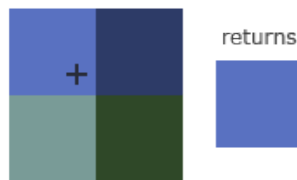

`GL_LINEAR` (also known as **(bi)linear filtering**) takes an interpolated value from the texture coordinate's neighboring texels, approximating a color between the texels. The smaller the distance from the texture coordinate to a texel's center, the more that texel's color contributes to the sampled color. Below we can see that a mixed color of the neighboring pixels is returned:

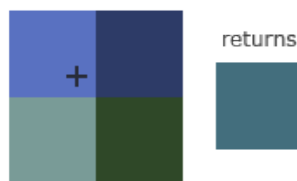

But what is the visual effect of such a texture filtering method? Let's see how these methods work when using a texture with a low resolution on a large object (texture is therefore scaled upwards and individual texels are noticeable):

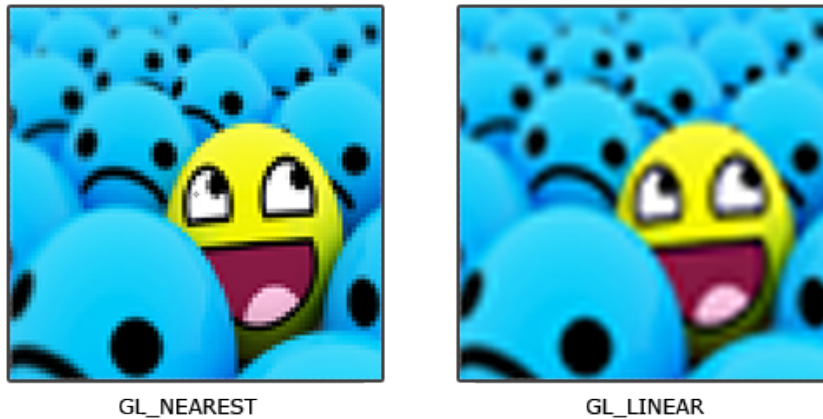

`GL_NEAREST` results in blocked patterns where we can clearly see the pixels that form the texture while `GL_LINEAR` produces a smoother pattern where the individual pixels are less visible. `GL_LINEAR` produces a more realistic output, but some developers prefer a more 8-bit look and as a result pick the `GL_NEAREST` option.

Texture filtering can be set for **magnifying** and **minifying** operations (when scaling up or downwards) so you could for example use nearest neighbor filtering when textures are scaled downwards and linear filtering for upscaled textures. We thus have to specify the filtering method for both options via `glTexParameter*`. The code should look similar to setting the wrapping method:

```
glTexParameteri(GL_TEXTURE_2D, GL_TEXTURE_MIN_FILTER, GL_NEAREST);  
glTexParameteri(GL_TEXTURE_2D, GL_TEXTURE_MAG_FILTER, GL_LINEAR);
```

7.2.1 Mipmaps

Imagine if we had a large room with thousands of objects, each with an attached texture. There will be objects far away that have the same high resolution texture attached as the objects close to the viewer. Since the objects are far away and probably only produce a few fragments, OpenGL has difficulties retrieving the right color value for its fragment from the high resolution texture, since it has to pick a texture color for a fragment that spans a large part of the texture. This will produce visible artifacts on small objects, not to mention the waste of memory to use high resolution textures on small objects.

To solve this issue OpenGL uses a concept called **mipmaps** that is basically a collection of texture images where each subsequent texture is twice as small compared to the previous one. The idea behind mipmaps should be easy to understand: after a certain distance threshold from the viewer, OpenGL will use a different mipmap texture that best suits the distance to the object. Because the object is far away, the smaller resolution will not be noticeable to the user. Also, mipmaps have the added bonus feature that they're good for performance as well. Let's take a closer look at what a mipmapped texture looks like:



Creating a collection of mipmapped textures for each texture image is cumbersome to do manually, but luckily OpenGL is able to do all the work for us with a single call to `glGenerateMipmaps` after we've created a texture. Later in the texture tutorial you'll see use of this function.

When switching between mipmaps levels during rendering OpenGL might show some artifacts like sharp edges visible between the two mipmap layers. Just like normal texture filtering, it is also possible to filter between mipmap levels using `NEAREST` and `LINEAR` filtering for switching between mipmap levels. To specify the filtering method between mipmap levels we can replace the original filtering methods with one of the following four options:

- `GL_NEAREST_MIPMAP_NEAREST`: takes the nearest mipmap to match the pixel size and uses nearest neighbor interpolation for texture sampling.
- `GL_LINEAR_MIPMAP_NEAREST`: takes the nearest mipmap level and samples using linear interpolation.
- `GL_NEAREST_MIPMAP_LINEAR`: linearly interpolates between the two mipmaps that most closely match the size of a pixel and samples via nearest neighbor interpolation.
- `GL_LINEAR_MIPMAP_LINEAR`: linearly interpolates between the two closest mipmaps and samples the texture via linear interpolation.

Just like texture filtering we can set the filtering method to one of the 4 aforementioned methods using `glTexParameteri`:

```
glTexParameteri(GL_TEXTURE_2D, GL_TEXTURE_MIN_FILTER,  
                GL_LINEAR_MIPMAP_LINEAR);  
glTexParameteri(GL_TEXTURE_2D, GL_TEXTURE_MAG_FILTER, GL_LINEAR);
```

A common mistake is to set one of the mipmap filtering options as the magnification filter. This doesn't have any effect since mipmaps are primarily used for when textures get downscaled: texture magnification doesn't use mipmaps and giving it a mipmap filtering option will generate an OpenGL `GL_INVALID_ENUM` error code.

7.3 Loading and creating textures

The first thing we need to do to actually use textures is to load them into our application. Texture images can be stored in dozens of file formats, each with their own structure and ordering of data, so how do we get those images in our application? One solution would be to choose a file format we'd like to use, say `.PNG` and write our own image loader to convert the image format into a large array of bytes. While it's not very hard to write your own image loader, it's still cumbersome and what if you want to support more file formats? You'd then have to write an image loader for each format you want to support.

Another solution, and probably a good one, is to use an image-loading library that supports several popular formats and does all the hard work for us. A library like SOIL.

7.4 SOIL

SOIL stands for Simple OpenGL Image Library and supports the most popular image formats, is easy to use and can be downloaded from their webpage [here](#). Like most other libraries you'll have to generate the `.lib` yourself. You can use one of their solution files in `/projects` (don't worry if their visual studio version is older, you can just convert them to your newer version; this works almost all the time) to generate your own. Also, add the content of the `src` folder to your `includes` folder; don't forget to add `SOIL.lib` to your linker options and add `#include <SOIL.h>` at the top of your code.

For the following texture sections we're going to use an image of a [wooden container](#). To load an image in SOIL we use its `SOIL_load_image` function:

```
int width, height;
unsigned char* image = SOIL_load_image("container.jpg", &width, &height, 0,
    SOIL_LOAD_RGB);
```

The function first takes as input the location of an image file. It then expects you to give two ints as its second and third argument that SOIL will fill with the resulting image's *width* and *height*. We need the image's width and height for generating textures later on. The 4th argument specifies the number of *channels* the image has, but we're just going to leave this at 0. The last argument tells SOIL how it should load the image: we're only interested in the RGB values of the image. The result is then stored in a large char/byte array.

7.5 Generating a texture

Like any of the previous objects in OpenGL, textures are referenced with an ID; let's create one:

```
GLuint texture;
glGenTextures(1, &texture);
```

The `glGenTextures` function first takes as input how many textures we want to generate and stores them in a `GLuint` array given as its second argument (in our case just a single `GLuint`). Just like other objects we need to bind it so any subsequent texture commands will configure the currently bound texture:

```
glBindTexture(GL_TEXTURE_2D, texture);
```

Now that the texture is bound, we can start generating a texture using the previously loaded image data. Textures are generated with `glTexImage2D`:

```
glTexImage2D(GL_TEXTURE_2D, 0, GL_RGB, width, height, 0, GL_RGB,
    GL_UNSIGNED_BYTE, image);
glGenerateMipmap(GL_TEXTURE_2D);
```

This is a large function with quite a few parameters so we'll walk through them step-by-step:

- The first argument specifies the texture target; setting this to `GL_TEXTURE_2D` means this operation will generate a texture on the currently bound texture object at the same target (so any textures bound to targets `GL_TEXTURE_1D` or `GL_TEXTURE_3D` will not be affected).
- The second argument specifies the mipmap level for which we want to create a texture for if you want to set each mipmap level manually, but we'll leave it at the base level which is 0.
- The third argument tells OpenGL in what kind of format we want to store the texture. Our image has only RGB values so we'll store the texture with RGB values as well.
- The 4th and 5th argument sets the width and height of the resulting texture. We stored those earlier when loading the image so we'll use the corresponding variables.
- The next argument should always be 0 (some legacy stuff).
- The 7th and 8th argument specify the format and datatype of the source image. We loaded the image with RGB values and stored them as `chars` (bytes) so we'll pass in the corresponding values.
- The last argument is the actual image data.

Once `glTexImage2D` is called, the currently bound texture object now has the texture image attached to it. However, currently it only has the base-level of the texture image loaded and if we want to use mipmaps we have to specify all the different images manually (by continually incrementing the second argument) or, we could call `glGenerateMipmap` after generating the texture. This will automatically generate all the required mipmaps for the currently bound texture.

After we're done generating the texture and its corresponding mipmaps, it is good practice to free the image memory and unbind the texture object:

```
SOIL_free_image_data(image);
glBindTexture(GL_TEXTURE_2D, 0);
```

The whole process of generating a texture thus looks something like this:

```
GLuint texture;
glGenTextures(1, &texture);
glBindTexture(GL_TEXTURE_2D, texture);
// Set the texture wrapping/filtering options (on the currently bound
// texture object)
...
// Load and generate the texture
int width, height;
unsigned char* image = SOIL_load_image("container.jpg", &width, &height, 0,
    SOIL_LOAD_RGB);
glTexImage2D(GL_TEXTURE_2D, 0, GL_RGB, width, height, 0, GL_RGB,
    GL_UNSIGNED_BYTE, image);
glGenerateMipmap(GL_TEXTURE_2D);
SOIL_free_image_data(image);
glBindTexture(GL_TEXTURE_2D, 0);
```

7.6 Applying textures

For the upcoming sections we will use the rectangle shape drawn with `glDrawElements` from the final part of the [Hello-Triangle](#) tutorial. We need to inform OpenGL how to sample the texture so we'll have to update the vertex data with the texture coordinates:

```
GLfloat vertices[] = {
    // Positions      // Colors      // Texture Coords
    0.5f, 0.5f, 0.0f, 1.0f, 0.0f, 0.0f, 1.0f, 1.0f, // Top Right
    0.5f, -0.5f, 0.0f, 0.0f, 1.0f, 0.0f, 1.0f, 0.0f, // Bottom Right
    -0.5f, -0.5f, 0.0f, 0.0f, 0.0f, 1.0f, 0.0f, 0.0f, // Bottom Left
    -0.5f, 0.5f, 0.0f, 1.0f, 1.0f, 0.0f, 0.0f, 1.0f // Top Left
};
```

Since we've added an extra vertex attribute we again have to notify OpenGL of the new vertex format:

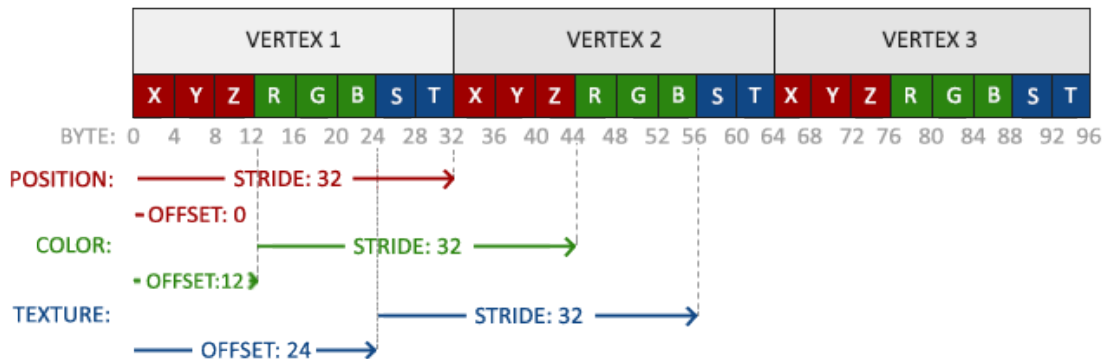

```
glVertexAttribPointer(2, 2, GL_FLOAT, GL_FALSE, 8 * sizeof(GLfloat), (GLvoid *) (6 * sizeof(GLfloat)));
glEnableVertexAttribArray(2);
```

Note that we have to adjust the stride parameter of the previous two vertex attributes to $8 * \text{sizeof}(\text{GLfloat})$ as well.

Next we need to alter the vertex shader to accept the texture coordinates as a vertex attribute and then forward the coordinates to the fragment shader:

```
#version 330 core
layout (location = 0) in vec3 position;
layout (location = 1) in vec3 color;
layout (location = 2) in vec2 texCoord;

out vec3 ourColor;
out vec2 TexCoord;

void main()
{
    gl_Position = vec4(position, 1.0f);
    ourColor = color;
    TexCoord = texCoord;
}
```

The fragment shader should then accept the `TexCoord` output variable as an input variable.

The fragment shader should also have access to the texture object, but how do we pass the texture object to the fragment shader? GLSL has a built-in data-type for texture objects called a **sampler** that takes as a postfix the texture type we want e.g. `sampler1D`, `sampler3D` or in

our case `sampler2D`. We can then add a texture to the fragment shader by simply declaring a uniform `sampler2D` that we later assign our texture to.

```
#version 330 core
in vec3 ourColor;
in vec2 TexCoord;

out vec4 color;

uniform sampler2D ourTexture;

void main()
{
    color = texture(ourTexture, TexCoord);
}
```

To sample the color of a texture we use GLSL's built-in `texture` function that takes as its first argument a texture sampler and as its second argument the corresponding texture coordinate. The `texture` function then samples the corresponding color value using the texture parameters we set earlier. The output of this fragment shader is then the (filtered) color of the texture at the (interpolated) texture coordinate.

All that's left to do now is to bind the texture before calling the `glDrawElements` and it will then automatically assign the texture to the fragment shader's sampler:

```
glBindTexture(GL_TEXTURE_2D, texture);
glBindVertexArray(VAO);
glDrawElements(GL_TRIANGLES, 6, GL_UNSIGNED_INT, 0);
glBindVertexArray(0);
```

If you did everything right you should see the following image:

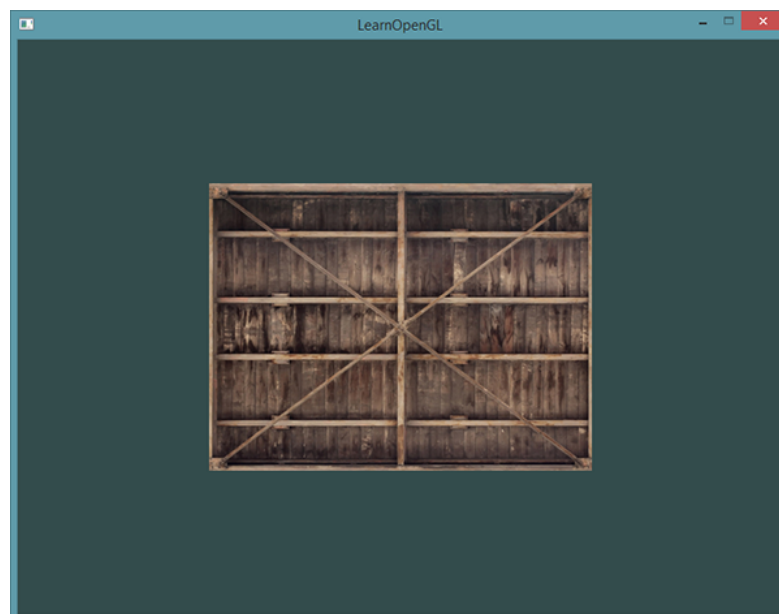

If your rectangle is completely white or black you probably made an error along the way. Check your shader logs and try to compare your code with the application's [source code](#).

To get a little funky we can also mix the resulting texture color with the vertex colors. We simply multiply the resulting texture color with the vertex color in the fragment shader to mix both colors:

```
color = texture(ourTexture, TexCoord) * vec4(ourColor, 1.0f);
```

The result should be a mixture of the vertex's color and the texture's color:

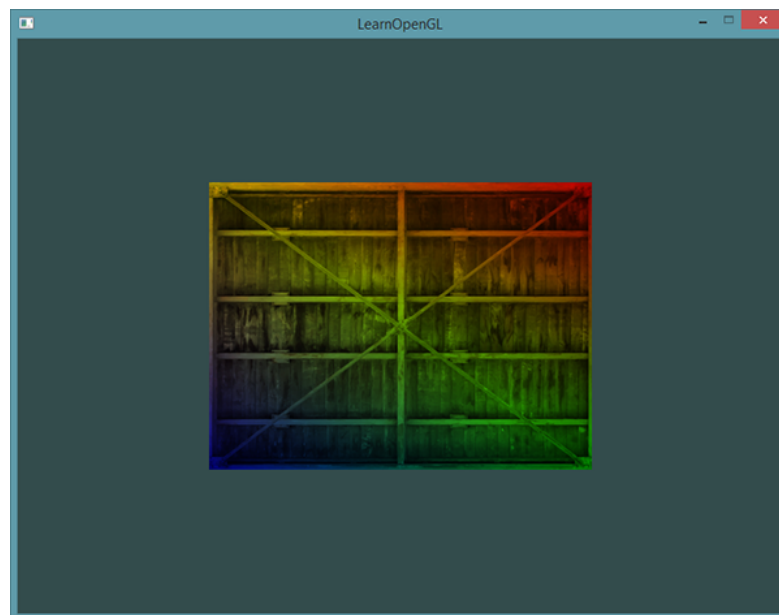

I guess you could say our container likes to disco.

7.7 Texture Units

You probably wondered why the `sampler2D` variable is a uniform if we didn't even assign it some value with `glUniform`. Using `glUniform1i` we can actually assign a *location* value to the texture sampler so we can set multiple textures at once in a fragment shader. This location of a texture is more commonly known as a **texture unit**. The default texture unit for a texture is 0 which is the default active texture unit so we did not had to assign a location in the previous section.

The main purpose of texture units is to allow us to use more than 1 texture in our shaders. By assigning texture units to the samplers, we can bind to multiple textures at once as long as we activate the corresponding texture unit first. Just like `glBindTexture` we can activate texture units using `glActiveTexture` passing in the texture unit we'd like to use:

```
glActiveTexture(GL_TEXTURE0); // Activate the texture unit first before
    binding texture
glBindTexture(GL_TEXTURE_2D, texture);
```

After activating a texture unit, a subsequent `glBindTexture` call will bind that texture to the currently active texture unit. Texture unit `GL_TEXTURE0` is always by default activated, so we didn't had to activate any texture units in the previous example when using `glBindTexture`.

OpenGL should have at least a minimum of 16 texture units for you to use which you can activate using `GL_TEXTURE0` to `GL_TEXTURE15`. They are defined in order so we could also get `GL_TEXTURE8` via `GL_TEXTURE0 + 8` for example, which is useful when we'd have to loop over several texture units.

We still however need to edit the fragment shader to accept another sampler. This should be relatively straightforward now:

```
#version 330 core
...

uniform sampler2D ourTexture1;
uniform sampler2D ourTexture2;

void main()
{
    color = mix(texture(ourTexture1, TexCoord), texture(ourTexture2,
    TexCoord), 0.2);
}
```

The final output color is now the combination of two texture lookups. GLSL's built-in `mix` function takes two values as input and linearly interpolates between them based on its third argument. If the third value is `0.0` it returns the first input; if it's `1.0` it returns the second input value. A value of `0.2` will return 80% of the first input color and 20% of the second input color, resulting in a mixture of both our textures.

We now want to load and create another texture; you should be familiar with the steps now. Make sure to create another texture object, load the image and generate the final texture using `glTexImage2D`. For the second texture we'll use an image of your [facial expression while learning OpenGL](#).

To use the second texture (and the first texture) we'd have to change the rendering procedure a bit by binding both textures to the corresponding texture unit and specifying which uniform sampler corresponds to which texture unit:

```
glActiveTexture(GL_TEXTURE0);
glBindTexture(GL_TEXTURE_2D, texture1);
glUniform1i(glGetUniformLocation(ourShader.Program, "ourTexture1"), 0);
glActiveTexture(GL_TEXTURE1);
glBindTexture(GL_TEXTURE_2D, texture2);
glUniform1i(glGetUniformLocation(ourShader.Program, "ourTexture2"), 1);

glBindVertexArray(VAO);
glDrawElements(GL_TRIANGLES, 6, GL_UNSIGNED_INT, 0);
glBindVertexArray(0);
```

Note that we're using `glUniform1i` to set the *location* or *texture-unit* of the uniform samplers. By setting them via `glUniform1i` we make sure each uniform sampler corresponds to the proper texture unit. You should get the following result:

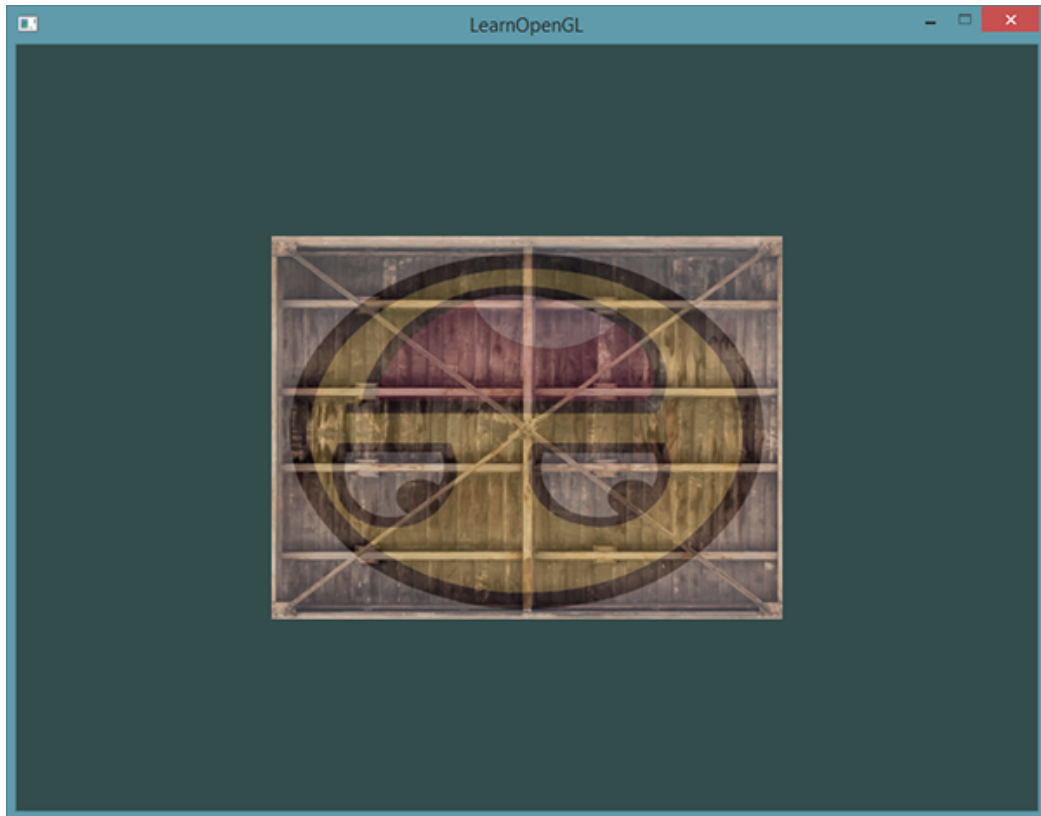

You probably noticed that the texture is flipped upside-down! This happens because OpenGL expects the 0.0 coordinate on the y-axis to be on the bottom side of the image, but images usually have 0.0 at the top of the y-axis. Some image loaders like [DevIL](#) have options to reposition the y-origin during loading, but SOIL doesn't. SOIL does have a function called `SOIL_load_OGL_texture` that loads **and** generates a texture with a flag called `SOIL_FLAG_INVERT_Y` that solves our problem. This function does however use features that are not available in modern OpenGL so we'd have to stick with `SOIL_load_image` for now and do the texture generation ourselves.

So to fix our little issue we have 2 options:

1. We can alter the texture coordinates in the vertex data and swap the y values (subtract the y coordinates from 1).
2. We can edit the vertex shader to swap the y -coordinate automatically by replacing the `TexCoord` assignment with `TexCoord = vec2(texCoord.x, 1.0f - texCoord.y);`

The provided solutions are small little hacks to get the picture flipped. This works in most cases, but is still implementation/texture-dependent so the best solution is to alter your image loader or edit your texture images in such a way that their y-origin suits OpenGL's needs.

Once you've either edited the vertex data or swapped the y -coordinate in the vertex shader you should get the following result:

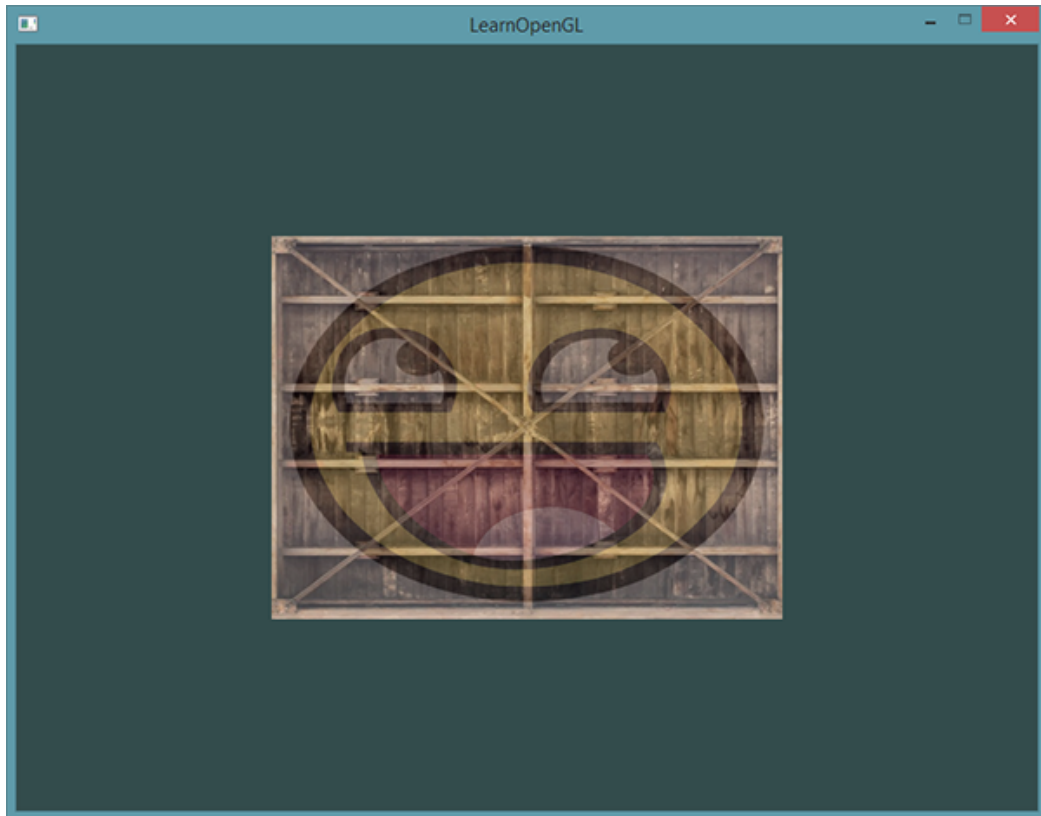

If you see one happy container, you did things right. You can compare it with the [source code](#) and the [vertex](#) or [fragment](#) shader.

7.8 Exercises

To get more comfortable with textures it is advised to work through these exercises before continuing.

- Make sure **only** the happy face looks in the other/reverse direction by changing the fragment shader: [solution](#).
- Experiment with the different texture wrapping methods by specifying texture coordinates in the range $0.0f$ to $2.0f$ instead of $0.0f$ to $1.0f$. See if you can display 4 smiley faces on a single container image clamped at its edge: [solution](#), [result](#). See if you can experiment with other wrapping methods as well.
- Try to display only the center pixels of the texture image on the rectangle in such a way that the individual pixels are getting visible by changing the texture coordinates. Try to set the texture filtering method to `GL_NEAREST` to see the pixels more clearly: [solution](#).
- Use a uniform variable as the `mix` function's third parameter to vary the amount the two textures are visible. Use the up and down arrow keys to change how much the container or the smiley face is visible: [solution](#), [fragment shader](#).

A futuristic cityscape with a flying vehicle in the foreground. The city is filled with tall, slender buildings and a flying vehicle with blue lights is in the foreground. The scene is set against a hazy, blue sky.

8. Transformations

We now know how to create objects, color them and/or give them a detailed appearance using textures, but they're still not that interesting since they're all static objects. We could try and make them move by changing their vertices and re-configuring their buffers each frame, but that's cumbersome and costs quite some processing power. There are much better ways to **transform** an object and that's by using (multiple) **matrix** objects. This doesn't mean we're going to talk about kungfu and a large digital artificial world.

Matrices are very powerful mathematical constructs that seem scary at first, but once you'll grow accustomed to them they'll prove extremely useful. When discussing matrices, we'll have to make a small dive into some mathematics and for the more mathematically inclined readers I'll post additional resources for further reading.

However, to fully understand transformations we first have to delve a bit deeper into vectors before discussing matrices. The focus of this chapter is to give you a basic mathematical background in topics we will require later on. If the subjects are difficult, try to understand them as much as you can and come back to this page later to review the concepts whenever you need them.

8.1 Vectors

In its most basic definition, vectors are directions and nothing more. A vector has a **direction** and a **magnitude** (also known as its strength or length). You can think of vectors like directions on a treasure map: 'go left 10 steps, now go north 3 steps and go right 5 steps'; here 'left' is the direction and '10 steps' is the magnitude of the vector. The directions for the treasure map thus contains 3 vectors. Vectors can have any dimension, but we usually work with dimensions of 2 to 4. If a vector has 2 dimensions it represents a direction on a plane (think of 2D graphs) and when it has 3 dimensions it can represent any direction in a 3D world.

Below you'll see 3 vectors where each vector is represented with (x, y) as arrows in a 2D

graph. Because it is more intuitive to display vectors in 2D (than in 3D) you can think of the 2D vectors as 3D vectors with a z coordinate of 0. Since vectors represent directions, the origin of the vector does not change its value. In the graph below we can see that the vectors \vec{v} and \vec{w} are equal even though their origin is different:

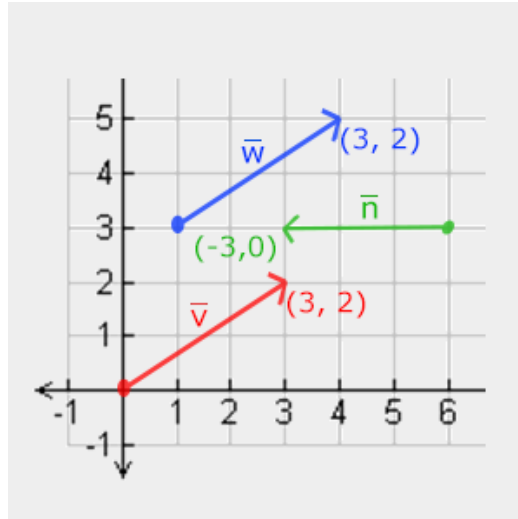

When describing vectors mathematicians generally prefer to describe vectors as character symbols with a little bar over their head like \vec{v} . Also, when displaying vectors in formulas they are generally displayed as follows:

$$\vec{v} = \begin{pmatrix} x \\ y \\ z \end{pmatrix}$$

Because vectors are specified as directions it is sometimes hard to visualize them as positions. What we basically visualize is we set the origin of the direction to $(0, 0, 0)$ and then point towards a certain direction that specifies the point, making it a **position vector** (we could also specify a different origin and then say: 'this vector points to that point in space from this origin'). The position vector $(3, 5)$ would then point to $(3, 5)$ on the graph with an origin of $(0, 0)$. Using vectors we can thus describe directions **and** positions in 2D and 3D space.

Just like with normal numbers we can also define several operations on vectors (some of which you've already seen).

8.2 Scalar vector operations

A **scalar** is a single digit (or a vector with 1 component if you'd like stay in vector-land). When adding/subtracting/multiplying or dividing a vector with a scalar we simply add/subtract/multiply or divide each element of the vector by the scalar. For addition it would look like this:

$$\begin{pmatrix} 1 \\ 2 \\ 3 \end{pmatrix} + x = \begin{pmatrix} 1+x \\ 2+x \\ 3+x \end{pmatrix}$$

Where $+$ can be $+$, $-$, \cdot or \div where \cdot is the multiplication operator. Keep in mind that for the $-$ and \div operator order the reverse order is not defined.

8.3 Vector negation

Negating a vector results in a vector in the reversed direction. A vector pointing north-east would point south-west after negation. To negate a vector we add a minus-sign to each component (you can also represent it as a scalar-vector multiplication with a scalar value of -1):

$$-\vec{v} = - \begin{pmatrix} v_x \\ v_y \\ v_z \end{pmatrix} = \begin{pmatrix} -v_x \\ -v_y \\ -v_z \end{pmatrix}$$

8.4 Addition and subtraction

Addition of two vectors is defined as **component-wise** addition, that is each component of one vector is added to the same component of the other vector like so:

$$\vec{v} = \begin{pmatrix} 1 \\ 2 \\ 3 \end{pmatrix}, \vec{k} = \begin{pmatrix} 4 \\ 5 \\ 6 \end{pmatrix} \rightarrow \vec{v} + \vec{k} = \begin{pmatrix} 1+4 \\ 2+5 \\ 3+6 \end{pmatrix} = \begin{pmatrix} 5 \\ 7 \\ 9 \end{pmatrix}$$

Visually, it looks like this on vectors $\vec{v} = (4, 2)$ and $\vec{k} = (1, 2)$:

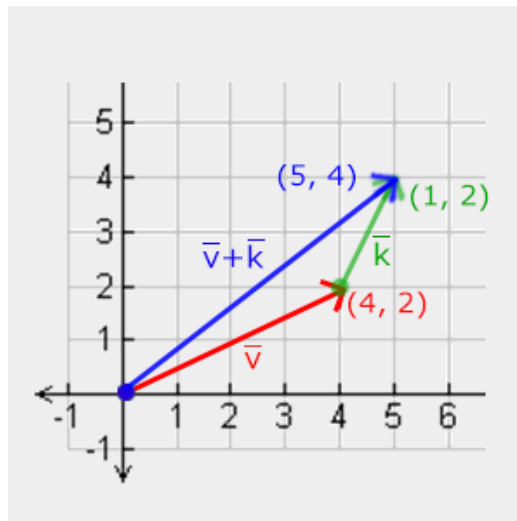

Just like normal addition and subtraction, vector subtraction is the same as addition with a negated second vector:

$$\vec{v} = \begin{pmatrix} 1 \\ 2 \\ 3 \end{pmatrix}, \vec{k} = \begin{pmatrix} 4 \\ 5 \\ 6 \end{pmatrix} \rightarrow \vec{v} + (-\vec{k}) = \begin{pmatrix} 1+(-4) \\ 2+(-5) \\ 3+(-6) \end{pmatrix} = \begin{pmatrix} -3 \\ -3 \\ -3 \end{pmatrix}$$

Subtracting two vectors from each other results in a vector that's the difference of the positions both vectors are pointing at. This proves useful in certain cases where we need to retrieve a vector that's the difference between two points.

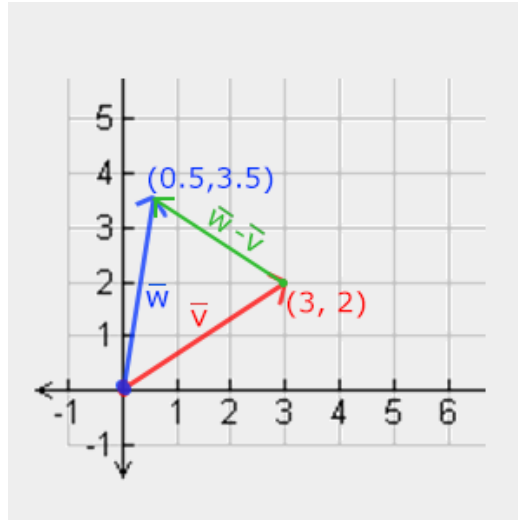

8.5 Length

To retrieve the length/magnitude of a vector we use the **Pythagoras theorem** that you might remember from your math classes. A vector forms a triangle when you visualize its individual x and y component as two sides of a triangle:

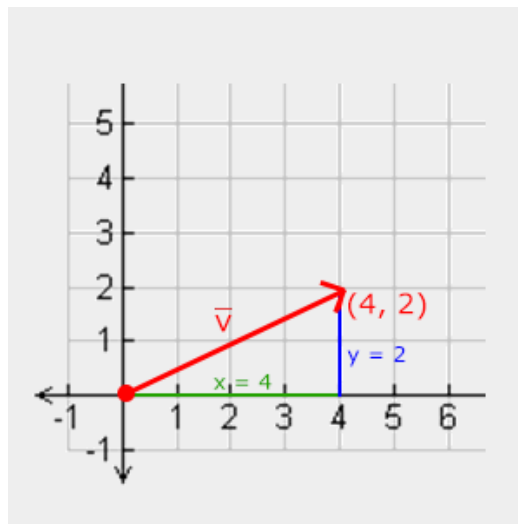

Since the length of the two sides (x , y) are known and we want to know the length of the tilted side \vec{v} we can calculate it using the Pythagoras theorem as:

$$\|\vec{v}\| = \sqrt{x^2 + y^2}$$

Where $\|\vec{v}\|$ is denoted as *the length of vector \vec{v}* . This is easily extended to 3D by adding z^2 to the equation.

In this case the length of vector $(4, 2)$ equals:

$$\|\vec{v}\| = \sqrt{4^2 + 2^2} = \sqrt{16 + 4} = \sqrt{20} = 4.47$$

Which is 4.47.

There is also a special type of vector that we call a **unit vector**. A unit vector has one extra property and that is that its length is exactly 1. We can calculate a unit vector \hat{n} from any vector by dividing each of the vector's components by its length:

$$\hat{n} = \frac{\vec{v}}{\|\vec{v}\|}$$

We call this **normalizing** a vector. Unit vectors are displayed with a little roof over their head and are generally easier to work with, especially when we only care about their directions (the direction does not change if we change a vector's length).

8.6 Vector-vector multiplication

Multiplying two vectors is a bit of a weird case. Normal multiplication isn't really defined on vectors since it has no visual meaning, but we have two specific cases that we could choose from when multiplying: one is the **dot product** denoted as $\vec{v} \cdot \vec{k}$ and the other is the **cross product** denoted as $\vec{v} \times \vec{k}$.

8.6.1 Dot product

The dot product of two vectors is equal to the scalar product of their lengths times the cosine of the angle between them. If this sounds confusing take a look at its formula:

$$\vec{v} \cdot \vec{k} = \|\vec{v}\| \cdot \|\vec{k}\| \cdot \cos \theta$$

Where the angle between them is represented as theta (θ). Why is this interesting? Well, imagine if \vec{v} and \vec{k} are unit vectors then their length would be equal to 1. This would effectively reduce the formula to:

$$\vec{v} \cdot \vec{k} = 1 \cdot 1 \cdot \cos \theta = \cos \theta$$

Now the dot product **only** defines the angle between both vectors. You might remember that the cosine or cos function becomes 0 when the angle is 90 degrees or 1 when the angle is 0. This allows us to easily test if the two vectors are **orthogonal** or parallel to each other using the dot product (orthogonal means the vectors are at a **right-angle** to each other). In case you want to know more about the **sin** or the **cosine** functions I'd suggest the following [Khan Academy videos](#) about basic trigonometry.

You can also calculate the angle between two non-unit vectors, but then you'd have to divide the lengths of both vectors from the result to be left with $\cos \theta$.

So how do we calculate the dot product? The dot product is a component-wise multiplication where we add the results together. It looks like this with two unit vectors (you can verify that both their lengths are exactly 1):

$$\begin{pmatrix} 0.6 \\ -0.8 \\ 0 \end{pmatrix} \cdot \begin{pmatrix} 0 \\ 1 \\ 0 \end{pmatrix} = (0.6 * 0) + (-0.8 * 1) + (0 * 0) = -0.8$$

To calculate the degree between both these unit vectors we use the inverse of the cosine function \cos^{-1} and this results in 143.1 degrees. We now effectively calculated the angle between these two vectors. The dot product proves very useful when doing lighting calculations.

8.6.2 Cross product

The cross product is only defined in 3D space and takes two non-parallel vectors as input and produces a third vector that is orthogonal to both the input vectors. If both the input vectors are orthogonal to each other as well, a cross product would result in 3 orthogonal vectors. This will prove useful in the upcoming tutorials. The following image shows what this looks like in 3D space:

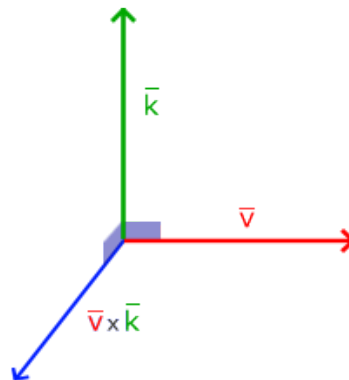

Unlike the other operations, the cross product isn't really intuitive without delving into linear algebra so it's best to just memorize the formula and you'll be fine (or don't, you'll probably be fine as well). Below you'll see the cross product between two orthogonal vectors A and B:

$$\begin{pmatrix} A_x \\ A_y \\ A_z \end{pmatrix} \times \begin{pmatrix} B_x \\ B_y \\ B_z \end{pmatrix} = \begin{pmatrix} A_y \cdot B_z - A_z \cdot B_y \\ A_z \cdot B_x - A_x \cdot B_z \\ A_x \cdot B_y - A_y \cdot B_x \end{pmatrix}$$

As you can see, it doesn't really seem to make sense. However, if you just follow these steps you'll get another vector that is orthogonal to your input vectors.

8.7 Matrices

Now that we've discussed almost all there is to vectors it is time to enter the matrix! A matrix is basically a rectangular array of numbers, symbols and/or expressions. Each individual item in a matrix is called an **element** of the matrix. An example of a 2x3 matrix is shown below:

$$\begin{bmatrix} 1 & 2 & 3 \\ 4 & 5 & 6 \end{bmatrix}$$

Matrices are indexed by (i, j) where i is the row and j is the column, that is why the above matrix is called a 2x3 matrix (3 columns and 2 rows, also known as the **dimensions** of the matrix). This is the opposite of what you're used to when indexing 2D graphs as (x, y) . To retrieve the value 4 we would index it as $(2, 1)$ (second row, first column).

Matrices are basically nothing more than that, just rectangular arrays of mathematical expressions. They do have a very nice set of mathematical properties and just like vectors we can define several operations on matrices, namely: addition, subtraction and multiplication.

8.8 Addition and subtraction

Addition and subtraction between a matrix and a scalar is defined as follows:

$$\begin{bmatrix} 1 & 2 \\ 3 & 4 \end{bmatrix} + 3 = \begin{bmatrix} 1+3 & 2+3 \\ 3+3 & 4+3 \end{bmatrix} = \begin{bmatrix} 4 & 5 \\ 6 & 7 \end{bmatrix}$$

The scalar value is basically added to each individual element of the matrix. The same applies for matrix-scalar subtraction:

$$\begin{bmatrix} 1 & 2 \\ 3 & 4 \end{bmatrix} - 3 = \begin{bmatrix} 1-3 & 2-3 \\ 3-3 & 4-3 \end{bmatrix} = \begin{bmatrix} -2 & -1 \\ 0 & 1 \end{bmatrix}$$

Matrix addition and subtraction between two matrices is done on a per-element basis. So the same general rules apply that we're familiar with for normal numbers, but done on the elements of both matrices with the same index. This does mean that addition and subtraction is only defined for matrices of the same dimensions. A 3x2 matrix and a 2x3 matrix (or a 3x3 matrix and a 4x4 matrix) cannot be added or subtracted together. Let's see how matrix addition works on two 2x2 matrices:

$$\begin{bmatrix} 1 & 2 \\ 3 & 4 \end{bmatrix} + \begin{bmatrix} 5 & 6 \\ 7 & 8 \end{bmatrix} = \begin{bmatrix} 1+5 & 2+6 \\ 3+7 & 4+8 \end{bmatrix} = \begin{bmatrix} 6 & 8 \\ 10 & 12 \end{bmatrix}$$

The same rules apply for matrix subtraction:

$$\begin{bmatrix} 4 & 2 \\ 1 & 6 \end{bmatrix} - \begin{bmatrix} 2 & 4 \\ 0 & 1 \end{bmatrix} = \begin{bmatrix} 4-2 & 2-4 \\ 1-0 & 6-1 \end{bmatrix} = \begin{bmatrix} 2 & -2 \\ 1 & 5 \end{bmatrix}$$

8.9 Matrix-scalar products

Just like addition and subtraction, a matrix-scalar product multiplies each element of the matrix by a scalar. The following example illustrates the multiplication:

$$2 \cdot \begin{bmatrix} 1 & 2 \\ 3 & 4 \end{bmatrix} = \begin{bmatrix} 2 \cdot 1 & 2 \cdot 2 \\ 2 \cdot 3 & 2 \cdot 4 \end{bmatrix} = \begin{bmatrix} 2 & 4 \\ 6 & 8 \end{bmatrix}$$

Now it also makes sense as to why those single numbers are called scalars. A scalar basically *scales* all the elements of the matrix by its value. In the previous example, all elements were scaled by 2.

So far so good, all of our cases weren't really too complicated. That is, until we start on matrix-matrix multiplication.

8.10 Matrix-matrix multiplication

Multiplying matrices is not necessarily complex, but rather difficult to get comfortable with. Matrix multiplication basically means to follow a set of pre-defined rules when multiplying. There are a few restrictions though:

1. You can only multiply two matrices if the number of columns on the left-hand side matrix is equal to the number of rows on the right-hand side matrix.
2. Matrix multiplication is not **commutative** that is $A \cdot B \neq B \cdot A$.

Let's get started with an example of a matrix multiplication of 2 \times 2 matrices:

$$\begin{bmatrix} 1 & 2 \\ 3 & 4 \end{bmatrix} \cdot \begin{bmatrix} 5 & 6 \\ 7 & 8 \end{bmatrix} = \begin{bmatrix} 1 \cdot 5 + 2 \cdot 7 & 1 \cdot 6 + 2 \cdot 8 \\ 3 \cdot 5 + 4 \cdot 7 & 3 \cdot 6 + 4 \cdot 8 \end{bmatrix} = \begin{bmatrix} 19 & 22 \\ 43 & 50 \end{bmatrix}$$

Right now you're probably trying to figure out what the hell just happened? Matrix multiplication is a combination of normal multiplication and addition using the left-matrix's rows with the right-matrix's columns. Let's try discussing this with the following image:

$$\begin{bmatrix} 1 & 2 \\ 3 & 4 \end{bmatrix} \cdot \begin{bmatrix} 5 & 6 \\ 7 & 8 \end{bmatrix} = \begin{bmatrix} 1 \cdot 5 + 2 \cdot 7 & 1 \cdot 6 + 2 \cdot 8 \\ 3 \cdot 5 + 4 \cdot 7 & 3 \cdot 6 + 4 \cdot 8 \end{bmatrix} = \begin{bmatrix} 19 & 22 \\ 43 & 50 \end{bmatrix}$$

We first take the upper row of the left matrix and then take a column from the right matrix. The row and column that we picked decides which output value of the resulting 2×2 matrix we're going to calculate. If we take the first row of the left matrix the resulting value will end up in the first row of the result matrix, then we pick a column and if it's the first column the result value will end up in the first column of the result matrix. This is exactly the case of the red pathway. To calculate the bottom-right result we take the bottom row of the first matrix and the rightmost column of the second matrix.

To calculate the resulting value we multiply the first element of the row and column together using normal multiplication, we do the same for the second elements, third, fourth etc. The results of the individual multiplications are then summed up and we have our result. Now it also makes

sense that one of the requirements is that the size of the left-matrix's columns and the right-matrix's rows are equal, otherwise we can't finish the operations!

The result is then a matrix that has dimensions of (n, m) where n is equal to the number of rows of the left-hand side matrix and m is equal to the columns of the right-hand side matrix.

Don't worry if you have difficulties imagining the multiplications inside your head. Just keep trying to do the calculations by hand and return to this page whenever you have difficulties. Over time, matrix multiplication becomes second nature to you.

Let's finish the discussion of matrix-matrix multiplication with a larger example. Try to visualize the pattern using the colors. As a useful exercise, see if you can come up with your own answer of the multiplication and then compare them with the resulting matrix (once you try to do a matrix multiplication by hand you'll quickly get the grasp of them).

$$\begin{bmatrix} 4 & 2 & 0 \\ 0 & 8 & 1 \\ 0 & 1 & 0 \end{bmatrix} \cdot \begin{bmatrix} 4 & 2 & 1 \\ 2 & 0 & 4 \\ 9 & 4 & 2 \end{bmatrix} = \begin{bmatrix} 4 \cdot 4 + 2 \cdot 2 + 0 \cdot 9 & 4 \cdot 2 + 2 \cdot 0 + 0 \cdot 4 & 4 \cdot 1 + 2 \cdot 4 + 0 \cdot 2 \\ 0 \cdot 4 + 8 \cdot 2 + 1 \cdot 9 & 0 \cdot 2 + 8 \cdot 0 + 1 \cdot 4 & 0 \cdot 1 + 8 \cdot 4 + 1 \cdot 2 \\ 0 \cdot 4 + 1 \cdot 2 + 0 \cdot 9 & 0 \cdot 2 + 1 \cdot 0 + 0 \cdot 4 & 0 \cdot 1 + 1 \cdot 4 + 0 \cdot 2 \end{bmatrix} = \begin{bmatrix} 20 & 8 & 12 \\ 25 & 4 & 34 \\ 2 & 0 & 4 \end{bmatrix}$$

As you can see, matrix-matrix multiplication is quite a cumbersome process and very prone to errors (which is why we usually let computers do this) and this gets problematic real quick when the matrices become larger. If you're still thirsty for more and you're curious about some more of the mathematical properties of matrices I strongly suggest you take a look at these [Khan Academy videos](#) about matrices.

Anyways, now that we know how to multiply matrices together, we can start getting to the good stuff.

8.11 Matrix-Vector multiplication

Up until now we've had our fair share of vectors these tutorials. We used vectors to represent positions, colors and even texture coordinates. Let's move a bit further down the rabbit hole and tell you that a vector is basically a $N \times 1$ matrix where N is the vector's number of components (also known as an **N-dimensional** vector). If you think about it, it makes a lot of sense. Vectors are just like matrices an array of numbers, but with only 1 column. So, how does this new piece of information help us? Well, if we have a $M \times N$ matrix we can multiply this matrix by our $N \times 1$ vector, since the columns of our matrix are equal to the number of rows of our vector, thus matrix multiplication is defined.

But why do we care if we can multiply matrices with a vector? Well, it just so happens that there are lots of interesting 2D/3D transformations we can place inside a matrix and multiplying that matrix with our vector basically *transforms* our vector. In case you're still a bit confused, let's start with some examples and you'll soon see what we mean.

8.12 Identity matrix

In OpenGL we usually work with 4×4 transformation matrices for several reasons and one of them is that most of the vectors are of size 4. The most simple transformation matrix that we can think of is the **identity matrix**. The identity matrix is an $N \times N$ matrix with only 0s except on its diagonal. As you'll see, this transformation matrix leaves a vector completely unharmed:

$$\begin{bmatrix} 1 & 0 & 0 & 0 \\ 0 & 1 & 0 & 0 \\ 0 & 0 & 1 & 0 \\ 0 & 0 & 0 & 1 \end{bmatrix} \cdot \begin{bmatrix} 1 \\ 2 \\ 3 \\ 4 \end{bmatrix} = \begin{bmatrix} 1 \cdot 1 \\ 1 \cdot 2 \\ 1 \cdot 3 \\ 1 \cdot 4 \end{bmatrix} = \begin{bmatrix} 1 \\ 2 \\ 3 \\ 4 \end{bmatrix}$$

The vector seems completely untouched. This becomes obvious from the rules of multiplication: the first result element is each individual element of the first row of the matrix multiplied with each element of the vector. Since each of the row's elements are 0 except the first one, we get: $1 \cdot 1 + 0 \cdot 2 + 0 \cdot 3 + 0 \cdot 4 = 1$ and the same applies for the other 3 elements of the vector.

You might be wondering what the use is of a transformation matrix that does not transform? The identity matrix is usually a starting point for generating other transformation matrices and if we dig even deeper into linear algebra, a very useful matrix for proving theorems and solving linear equations.

8.13 Scaling

When we're scaling a vector we are increasing the length of the arrow by amount we'd like to scale, keeping its direction the same. Since we're working in either 2 or 3 dimensions we can define scaling by a vector of 2 or 3 scaling variables, each scaling one axis (x, y or z).

Let's try scaling the vector $\vec{v} = (3, 2)$. We will scale the vector along the x-axis by 0.5, thus making it twice as narrow; and we'll scale the vector by 2 along the y-axis, making it twice as high. Let's see what it looks like if we scale the vector by $(0.5, 2)$ as \vec{s} :

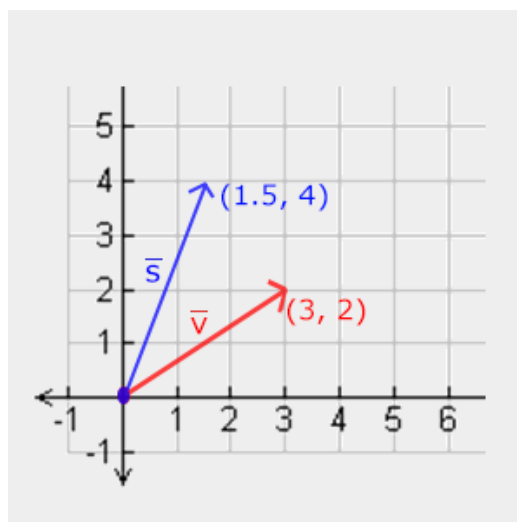

Keep in mind that OpenGL usually operates in 3D space so for this 2D case we could set the z-axis scale to 1 thus leaving it unharmed. The scaling operation we just performed is a **non-uniform**

scale, because the scaling factor is not the same for each axis. If the scalar would be equal on all axes it would be called a **uniform scale**.

Let's start building a transformation matrix that does the scaling for us. We saw from the identity matrix that each of the diagonal elements were multiplied with its corresponding vector element. What if we were to change the 1s in the identity matrix to 3s? In that case, we would be multiplying each of the vector elements by a value of 3 and thus effectively scale the vector by 3. If we represent the scaling variables as (S_1, S_2, S_3) we can define a scaling matrix on any vector (x, y, z) as:

$$\begin{bmatrix} S_1 & 0 & 0 & 0 \\ 0 & S_2 & 0 & 0 \\ 0 & 0 & S_3 & 0 \\ 0 & 0 & 0 & 1 \end{bmatrix} \cdot \begin{pmatrix} x \\ y \\ z \\ 1 \end{pmatrix} = \begin{pmatrix} S_1 \cdot x \\ S_2 \cdot y \\ S_3 \cdot z \\ 1 \end{pmatrix}$$

Note that the 4th scaling vector stays 1, since it's undefined to scale the w component in a 3D space. The w component is used for other purposes as we'll see later on.

8.14 Translation

Translation is the process of adding another vector on top of the original vector to return a new vector with a different position, thus *moving* the vector based on a translation vector. We've already discussed vector addition so this shouldn't be too new.

Just like the scaling matrix there are several locations on a 4-by-4 matrix that we can use to perform certain operations and for translation those are the top-3 values of the 4th column. If we represent the scaling vector as (T_x, T_y, T_z) we can define the translation matrix by:

$$\begin{bmatrix} 1 & 0 & 0 & T_x \\ 0 & 1 & 0 & T_y \\ 0 & 0 & 1 & T_z \\ 0 & 0 & 0 & 1 \end{bmatrix} \cdot \begin{pmatrix} x \\ y \\ z \\ 1 \end{pmatrix} = \begin{pmatrix} x + T_x \\ y + T_y \\ z + T_z \\ 1 \end{pmatrix}$$

This works because all of the translation values are multiplied by the vector's w column and added to the vector's original values (remember the matrix-multiplication rules). This wouldn't have been possible with a 3-by-3 matrix.

Homogeneous coordinates

The w component of a vector is also known as a **homogeneous coordinate**. To get the 3D vector from a homogeneous vector we divide the x , y and z coordinate by its w coordinate. We usually do not notice this since the w component is 1. 0 most of the time. Using homogeneous coordinates has several advantages: it allows us to do translations on 3D vectors (without a w component we can't translate vectors) and in the next chapter we'll use the w value to create 3D visuals.

Also, whenever the homogeneous coordinate is equal to 0 the vector is specifically known as a **direction vector** since a vector with a w coordinate of 0 cannot be translated.

With a translation matrix we could move objects in any of the 3 directions (x , y , z) we'd like, making it a very useful transformation matrix for our transformation toolkit.

8.15 Rotation

The last few transformations were relatively easy to understand and visualize in 2D or 3D space, but rotations are a bit trickier. If you want to know exactly how these matrices are constructed I'd recommend that you watch the rotation items of Khan Academy's [linear algebra](#) videos.

First let's define what a rotation of a vector actually is. A rotation in 2D or 3D is represented with an **angle**. An angle could be in degrees or radians where a whole circle has 360 degrees or 2π radians. I personally prefer to work in degrees, since they seem to make more sense to me.

Most rotation functions require an angle in radians, but luckily degrees are easily converted to radians:

angle in degrees = angle in radians * (180.0f / PI)

angle in radians = angle in degrees * (PI / 180.0f)

Where PI equals (sort of) 3.14159265359.

Rotating half a circle would rotate us $360/2 = 180$ degrees and rotating 1/5th to the right means we rotate $360/5 = 72$ degrees to the right. This is demonstrated for a basic 2D vector where \vec{v} is rotated 72 degrees to the right from \vec{k} :

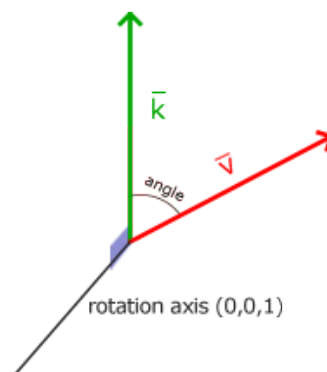

Rotations in 3D are specified with an angle **and** a **rotation axis**. The angle specified will rotate the object along the rotation axis given. Try to visualize this by spinning your head a certain degree while continually looking down a single rotation axis. When rotating 2D vectors in a 3D world for example, we set the rotation axis to the z-axis (try to visualize this).

Using trigonometry it is possible to transform vectors to new rotated vectors given an angle. This is usually done via a smart combination of the `sine` and `cosine` function (commonly abbreviated to `sin` and `cos`). A discussion of how the transformation matrices are generated is out of the scope of this tutorial.

A rotation matrix is defined for each unit axis in 3D space where the angle is represented as the theta symbol θ .

Rotation around the X-axis:

$$\begin{bmatrix} 1 & 0 & 0 & 0 \\ 0 & \cos \theta & -\sin \theta & 0 \\ 0 & \sin \theta & \cos \theta & 0 \\ 0 & 0 & 0 & 1 \end{bmatrix} \cdot \begin{pmatrix} x \\ y \\ z \\ 1 \end{pmatrix} = \begin{pmatrix} x \\ \cos \theta \cdot y - \sin \theta \cdot z \\ \sin \theta \cdot y + \cos \theta \cdot z \\ 1 \end{pmatrix}$$

Rotation around the Y-axis:

$$\begin{bmatrix} \cos \theta & 0 & \sin \theta & 0 \\ 0 & 1 & 0 & 0 \\ -\sin \theta & 0 & \cos \theta & 0 \\ 0 & 0 & 0 & 1 \end{bmatrix} \cdot \begin{pmatrix} x \\ y \\ z \\ 1 \end{pmatrix} = \begin{pmatrix} \cos \theta \cdot x + \sin \theta \cdot z \\ y \\ -\sin \theta \cdot x + \cos \theta \cdot z \\ 1 \end{pmatrix}$$

Rotation around the Z-axis:

$$\begin{bmatrix} \cos \theta & -\sin \theta & 0 & 0 \\ \sin \theta & \cos \theta & 0 & 0 \\ 0 & 0 & 1 & 0 \\ 0 & 0 & 0 & 1 \end{bmatrix} \cdot \begin{pmatrix} x \\ y \\ z \\ 1 \end{pmatrix} = \begin{pmatrix} \cos \theta \cdot x - \sin \theta \cdot y \\ \sin \theta \cdot x + \cos \theta \cdot y \\ z \\ 1 \end{pmatrix}$$

Using the rotation matrices we can transform our position vectors around one of the three unit axes. It is also possible to combine them by first rotating around the X-axis and then the Y-axis for example. However, this quickly introduces a problem called **Gimbal lock**. We won't discuss the details, but a better solution is to rotate around an arbitrary unit axis e.g. $(0.662, 0.2, 0.722)$ (note that this is a unit vector) right away instead of combining the rotation matrices. Such a (nasty) matrix exists and is given below with (R_x, R_y, R_z) as the arbitrary rotation axis:

$$\begin{bmatrix} \cos \theta + R_x^2(1 - \cos \theta) & R_x R_y(1 - \cos \theta) - R_z \sin \theta & R_x R_z(1 - \cos \theta) + R_y \sin \theta & 0 \\ R_y R_x(1 - \cos \theta) + R_z \sin \theta & \cos \theta + R_y^2(1 - \cos \theta) & R_y R_z(1 - \cos \theta) - R_x \sin \theta & 0 \\ R_z R_x(1 - \cos \theta) - R_y \sin \theta & R_z R_y(1 - \cos \theta) + R_x \sin \theta & \cos \theta + R_z^2(1 - \cos \theta) & 0 \\ 0 & 0 & 0 & 1 \end{bmatrix}$$

A mathematical discussion of generating such a matrix is out of the scope of this tutorial. Keep in mind that even this matrix does not completely prevent gimbal lock (although it gets a lot harder). To truly prevent Gimbal locks we have to represent rotations using **quaternions**, that are not only safer, but also more computationally friendly. However, a discussion of quaternions is reserved for a later tutorial.

8.16 Combining matrices

The true power from using matrices for transformations is that we can combine multiple transformations in a single matrix thanks to matrix-matrix multiplication. Let's see if we can generate a transformation matrix that combines several transformations. Say we have a vector (x, y, z) and

we want to scale it by 2 and then translate it by $(1, 2, 3)$. We need a translation and a scaling matrix for our required steps. The resulting transformation matrix would then look like:

$$Trans.Scale = \begin{bmatrix} 1 & 0 & 0 & 1 \\ 0 & 1 & 0 & 2 \\ 0 & 0 & 1 & 3 \\ 0 & 0 & 0 & 1 \end{bmatrix} \cdot \begin{bmatrix} 2 & 0 & 0 & 0 \\ 0 & 2 & 0 & 0 \\ 0 & 0 & 2 & 0 \\ 0 & 0 & 0 & 1 \end{bmatrix} = \begin{bmatrix} 2 & 0 & 0 & 1 \\ 0 & 2 & 0 & 2 \\ 0 & 0 & 2 & 3 \\ 0 & 0 & 0 & 1 \end{bmatrix}$$

Note that we first do a translation and then a scale transformation when multiplying matrices. Matrix multiplication is not commutative, which means their order is important. When multiplying matrices the right-most matrix is first multiplied with the vector so you should read the multiplications from right to left. It is advised to first do scaling operations, then rotations and lastly translations when combining matrices otherwise they might (negatively) affect each other. For example, if you would first do a translation and then scale, the translation vector would also scale!

Running the final transformation matrix on our vector results in the following vector:

$$\begin{bmatrix} 2 & 0 & 0 & 1 \\ 0 & 2 & 0 & 2 \\ 0 & 0 & 2 & 3 \\ 0 & 0 & 0 & 1 \end{bmatrix} \cdot \begin{bmatrix} x \\ y \\ z \\ 1 \end{bmatrix} = \begin{bmatrix} 2x+1 \\ 2y+2 \\ 2z+3 \\ 1 \end{bmatrix}$$

Great! The vector is first scaled by two and then translated by $(1, 2, 3)$.

8.17 In practice

Now that we've explained all the theory behind transformations, it's time to see how we can actually use this knowledge to our advantage. OpenGL does not have any form of matrix or vector knowledge built in, so we have to define our own mathematics classes and functions. In the tutorials we'd rather abstract from all the tiny mathematical details and simply use pre-made mathematics libraries. Luckily, there is an easy-to-use and tailored-for-OpenGL mathematics library called GLM.

8.18 GLM



GLM stands for OpenGL Mathematics and is a *header-only* library, which means that we only have to include the proper header files and we're done; no linking and compiling necessary. GLM can be downloaded from their [website](#). Copy the root directory of the header files into your *includes* folder and let's get rolling.

Most of GLM's functionality that we need can be found in only 3 headers files that we'll include as follows:

```
#include <glm/glm.hpp>
#include <glm/gtc/matrix_transform.hpp>
#include <glm/gtc/type_ptr.hpp>
```

Let's see if we can put our transformation knowledge to good use by translating a vector of $(1, 0, 0)$ by $(1, 1, 0)$ (note that we define it as a `glm::vec4` with its homogenous coordinate set to `1.0`):

```
glm::vec4 vec(1.0f, 0.0f, 0.0f, 1.0f);
glm::mat4 trans;
trans = glm::translate(trans, glm::vec3(1.0f, 1.0f, 0.0f));
vec = trans * vec;
std::cout << vec.x << vec.y << vec.z << std::endl;
```

We first define a vector named `vec` using GLM's built-in vector class. Next we define a `mat4` which is a 4-by-4 identity matrix by default. The next step is to create a transformation matrix by passing our identity matrix to the `glm::translate` function, together with a translation vector (the given matrix is then multiplied with a translation matrix and the resulting matrix is returned).

Then we multiply our vector by the transformation matrix and output the result. If we still remember how matrix translation works then the resulting vector should be $(1+1, 0+1, 0+0)$ which is $(2, 1, 0)$. This snippet of code outputs `210` so the translation matrix did its job.

Let's do something more interesting and scale and rotate the container object from the previous tutorial. First we'll rotate the container by 90 degrees counter-clockwise. Then we scale it by `0.5`, thus making it twice as small. Let's create the transformation matrix first:

```
glm::mat4 trans;
trans = glm::rotate(trans, 90.0f, glm::vec3(0.0, 0.0, 1.0));
trans = glm::scale(trans, glm::vec3(0.5, 0.5, 0.5));
```

First we scale the container by `0.5` on each axis and then rotate the container 90 degrees around the Z-axis. Note that the textured rectangle is on the XY plane so we want to rotate around the Z-axis. Because we pass the matrix to each of GLM's functions, GLM automatically multiples the matrices together, resulting in a transformation matrix that combines all the transformations.

Some versions of GLM take the angle in radians instead of degrees in which case you can convert it to radians with `glm::radians(90.0f)`.

The next big question is: how do we get the transformation matrix to the shaders? We shortly mentioned before that GLSL also has a `mat4` type. So we'll adapt the vertex shader to accept a `mat4` uniform variable and multiply the position vector by the matrix uniform:

```
#version 330 core
layout (location = 0) in vec3 position;
layout (location = 1) in vec3 color;
layout (location = 2) in vec2 texCoord;

out vec3 ourColor;
out vec2 TexCoord;

uniform mat4 transform;

void main()
{
    gl_Position = transform * vec4(position, 1.0f);
    ourColor = color;
```

```
TexCoord = vec2(texCoord.x, 1.0 - texCoord.y);  
}
```

GLSL also has `mat2` and `mat3` types that allow for swizzling-like operations just like vectors. All the aforementioned math operations (like scalar-matrix multiplication, matrix-vector multiplication and matrix-matrix multiplication) are allowed on the matrix types. Wherever special matrix operations are used we'll be sure to explain what's happening.

We added the uniform and multiplied the position vector with the transformation matrix before passing it to `gl_Position`. Our container should now be twice as small and rotated 90 degrees (tilted to the left). We still need to pass the transformation matrix to the shader though:

```
GLuint transformLoc = glGetUniformLocation(ourShader.Program, "transform");  
glUniformMatrix4fv(transformLoc, 1, GL_FALSE, glm::value_ptr(trans));
```

We first query the location of the uniform variable and then send the matrix data to the shaders via `glUniform` function with `Matrix4fv` as its postfix. The first argument should be familiar by now which is the uniform's location. The second argument tells OpenGL how many matrices we'd like to send, which is 1. The third argument asks us if we want to transpose our matrix, that is to swap the columns and rows. OpenGL uses an internal matrix layout that's called **column-major ordering** for their matrices under the hood. GLM already defines its matrices using column-major ordering so there is no need to transpose the matrices, we can keep it at `GL_FALSE`. The last parameter is the actual matrix data, but GLM stores their matrices not in the exact way that OpenGL likes to receive them so we first transform them with GLM's built-in function `value_ptr`.

We created a transformation matrix, declared a uniform in the vertex shader and sent the matrix to the shaders where we transform our vertex coordinates. The result should look something like this:

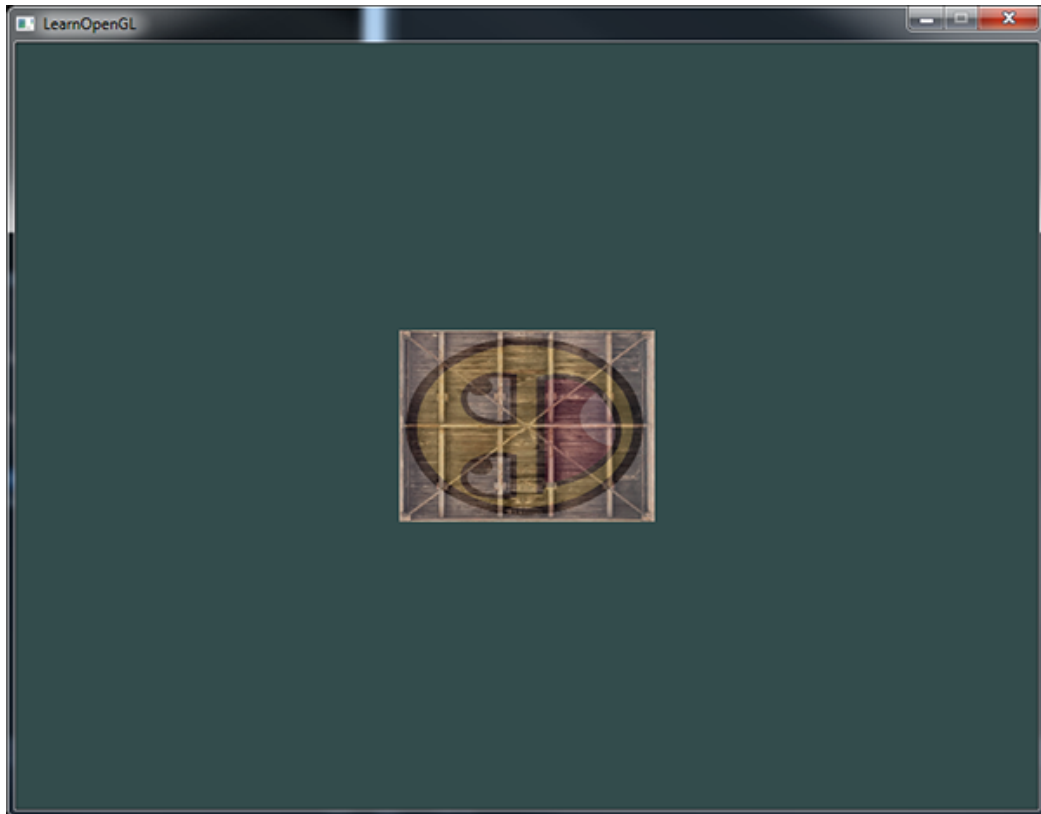

Perfect! Our container is indeed tilted to the left and twice as small so the transformation was successful. Let's get a little more funky and see if we can rotate the container over time and for fun we'll also reposition the container at the bottom-right side of the window. To rotate the container over time we have to update the transformation matrix in the game loop because it needs to update each render iteration. We use GLFW's time function to get the angle over time:

```
glm::mat4 trans;
trans = glm::translate(trans, glm::vec3(0.5f, -0.5f, 0.0f));
trans = glm::rotate(trans, (GLfloat)glfwGetTime() * 50.0f, glm::vec3(0.0f,
    0.0f, 1.0f));
```

Keep in mind that in the previous case we could declare the transformation matrix anywhere, but now we have to create it every iteration so we continuously update the rotation. This means we have to re-create the transformation matrix in each iteration of the game loop. Usually when rendering scenes we have several transformation matrices that are re-created with new values each render iteration.

Here we first rotate the container around the origin $(0, 0, 0)$ and once it's rotated, we translate its rotated version to the bottom-right corner of the screen. Remember that the actual transformation order should be read in reverse: even though in code we first translate and then later rotate, the actual transformations first apply a rotation and then a translation. Understanding all these combinations of transformations and how they apply to objects is difficult to understand. Try and experiment with transformations like these and you'll quickly get a grasp of it.

If you did things right you should get the following result:

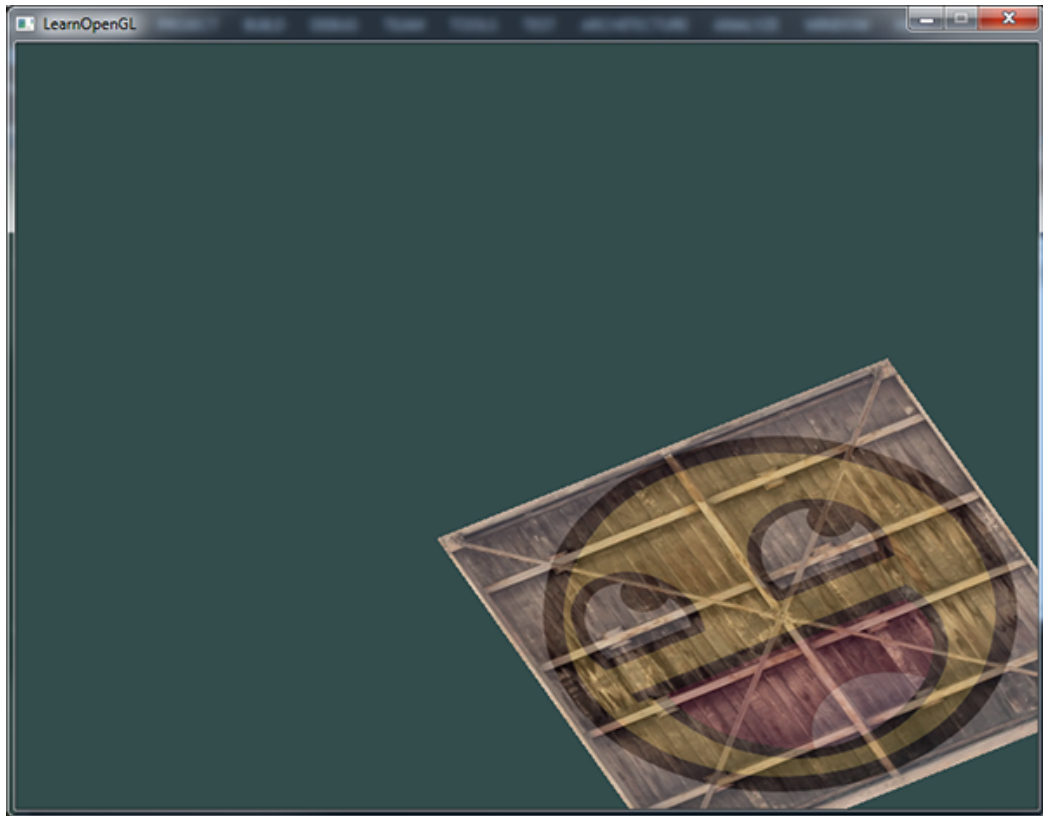

And there you have it. A translated container that's rotated over time, all done by a single transformation matrix! Now you can see why matrices are such a powerful construct in graphics land. We can define an infinite amount of transformations and combine them all in a single matrix that we can re-use as often as we'd like. Using transformations like this in the vertex shader saves us the effort of re-defining the vertex data and saves us some processing time as well, since we don't have to re-send our data all the time (which is quite slow).

If you didn't get the right result or you're stuck somewhere else. Take a look at the [source code](#) together with the [vertex](#) and [fragment](#) shader.

In the next tutorial we'll discuss how we can use matrices to define different coordinate spaces for our vertices. This will be our first step into real-time 3D graphics!

8.19 Exercises

- Using the last transformation on the container, try switching the order around by first rotating and then translating. See what happens and try to reason why this happens: [solution](#).
- Try drawing a second container with another call to `glDrawElements` but place it at a different position using transformations **only**. Make sure this second container is placed at the top-left of the window and instead of rotating, scale it over time (using the `sin` function is useful here; note that using `sin` will cause the object to invert as soon as a negative scale is applied): [solution](#).

A futuristic cityscape with a flying vehicle in the foreground. The vehicle is dark with blue lights and is flying towards the left. The city is composed of many tall, thin buildings, some of which are illuminated with blue light. The sky is a mix of blue and white, suggesting a bright day or a clear sky.

9. Coordinate Systems

In the last tutorial we learned how we can use matrices to our advantage by transforming all vertices with transformation matrices. OpenGL expects all the vertices, that we want to become visible, to be in normalized device coordinates after each vertex shader run. That is, the x , y and z coordinates of each vertex should be between -1.0 and 1.0 ; coordinates outside this range will not be visible. What we usually do, is specify the coordinates in a range we configure ourselves and in the vertex shader transform these coordinates to NDC. These NDC coordinates are then given to the rasterizer to transform them to 2D coordinates/pixels on your screen.

Transforming coordinates to NDC and then to screen coordinates is usually accomplished in a step-by-step fashion where we transform an object's vertices to several coordinate systems before finally transforming them to screen coordinates. The advantage of transforming them to several *intermediate* coordinate systems is that some operations/calculations are easier in certain coordinate systems as will soon become apparent. There are a total of 5 different coordinate systems that are of importance to us:

- Local space (or Object space)
- World space
- View space (or Eye space)
- Clip space
- Screen space

Those are all a different state at which our vertices will be transformed in before finally ending up as fragments.

You're probably quite confused by now by what a space or coordinate system actually is so we'll explain them in a more understandable fashion by showing the total picture and what each specific space actually does.

9.1 The global picture

To transform the coordinates in one space to the next coordinate space we'll use several transformation matrices of which the most important are the **model**, **view** and **projection** matrix. Our vertex coordinates first start in **local space** as **local coordinates** and are then further processed to **world coordinates**, **view coordinates**, **clip coordinates** and eventually end up as **screen coordinates**. The following image displays the process and shows what each transformation does:

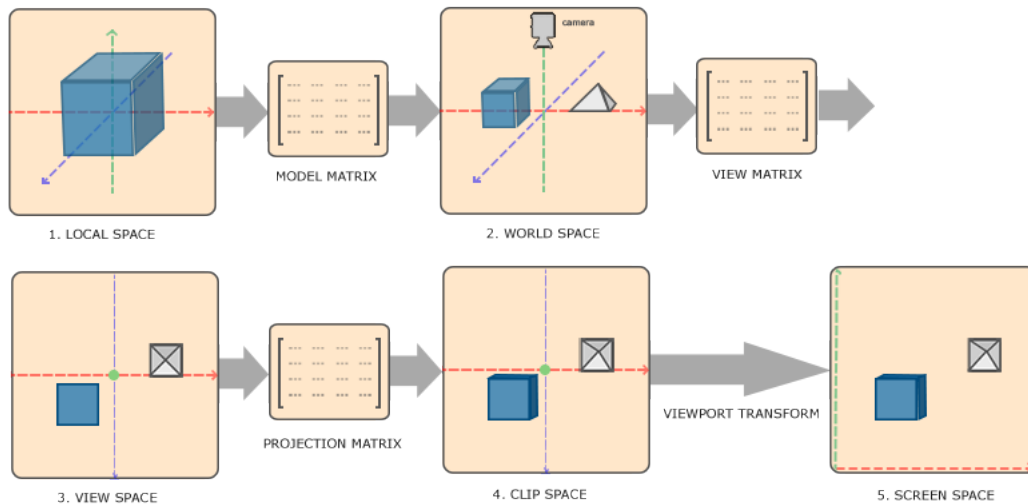

1. Local coordinates are the coordinates of your object relative to its local origin; they're the coordinates your object begins in.
2. The next step is to transform the local coordinates to world-space coordinates which are coordinates in respect of a larger world. These coordinates are relative to a global origin of the world, together with many other objects also placed relative to the world's origin.
3. Next we transform the world coordinates to view-space coordinates in such a way that each coordinate is as seen from the camera or viewer's point of view.
4. After the coordinates are in view space we want to project them to clip coordinates. Clip coordinates are processed to the -1.0 and 1.0 range and determine which vertices will end up on the screen.
5. And lastly we transform the clip coordinates to screen coordinates in a process we call **viewport transform** that transforms the coordinates from -1.0 and 1.0 to the coordinate range defined by `glViewport`. The resulting coordinates are then send to the rasterizer to turn them into fragments.

You probably got a slight idea what each individual space is used for. The reason we're transforming our vertices into all these different spaces is that some operations make more sense or are easier to use in certain coordinate systems. For example, when modifying your object it makes most sense to do this in local space, while calculating certain operations on the object with respect to the position of other objects makes most sense in world coordinates and so on. If we want, we could define one transformation matrix that goes from local space to clip space all in one go, but that leaves us with less flexibility.

We'll discuss each coordinate system in more detail below.

9.2 Local space

Local space is the coordinate space that is local to your object, i.e. where your object begins in. Imagine that you've created your cube in a modeling software package (like Blender). The origin of your cube is probably at $(0, 0, 0)$ even though your cube might end up at a different location in your final application. Probably all the models you've created all have $(0, 0, 0)$ as their initial position. All the vertices of your model are therefore in *local* space: they are all local to your object.

The vertices of the container we've been using were specified as coordinates between -0.5 and 0.5 with 0.0 as its origin. These are local coordinates.

9.3 World space

If we would import all our objects directly in the application they would probably all be somewhere stacked on each other around the world's origin of $(0, 0, 0)$ which is not what we want. We want to define a position for each object to position them inside a larger world. The coordinates in world space are exactly what they sound like: the coordinates of all your vertices relative to a (game) world. This is the coordinate space where you want your objects transformed to in such a way that they're all scattered around the place (preferably in a realistic fashion). The coordinates of your object are transformed from local to world space; this is accomplished with the *model* matrix.

The model matrix is a transformation matrix that translates, scales and/or rotates your object to place it in the world at a location/orientation they belong to. Think of it as transforming a house by scaling it down (it was a bit too large in local space), translating it to a suburbia town and rotating it a bit to the left on the y-axis so that it neatly fits with the neighboring houses. You could think of the matrix in the previous tutorial to position the container all over the scene as a sort of model matrix as well; we transformed the local coordinates of the container to some different place in the scene/world.

9.4 View space

The view space is what people usually refer to as the *camera* of OpenGL (it is sometimes also known as the *camera space* or *eye space*). The view space is the result of transforming your world-space coordinates to coordinates that are in front of the user's view. The view space is thus the space as seen from the camera's point of view. This is usually accomplished with a combination of translations and rotations to translate/rotate the scene so that certain items are transformed to the front of the camera. These combined transformations are generally stored inside a *view matrix* that transforms world coordinates to view space. In the next tutorial we'll extensively discuss how to create such a view matrix to simulate a camera.

9.5 Clip space

At the end of each vertex shader run, OpenGL expects the coordinates to be within a specific range and any coordinate that falls outside this range is *clipped*. Coordinates that are clipped are discarded, so the remaining coordinates will end up as fragments visible on your screen. This is also where *clip space* gets its name from.

Because specifying all the visible coordinates to be within the range -1.0 and 1.0 isn't really intuitive, we specify our own coordinate set to work in and convert those back to NDC as OpenGL expects them.

To transform vertex coordinates from view to clip-space we define a so called **projection matrix** that specifies a range of coordinates e.g. -1000 and 1000 in each dimension. The projection matrix then transforms coordinates within this specified range to normalized device coordinates ($-1.0, 1.0$). All coordinates outside this range will not be mapped between -1.0 and 1.0 and therefore be clipped. With this range we specified in the projection matrix, a coordinate of $(1250, 500, 750)$ would not be visible, since the x coordinate is out of range and thus gets converted to a coordinate higher than 1.0 in NDC and is therefore clipped.

Note that if only a part of a primitive e.g. a triangle is outside the **clipping volume** OpenGL will reconstruct the triangle as one or more triangles to fit inside the clipping range.

This *viewing box* a projection matrix creates is called a **frustum** and each coordinate that ends up inside this frustum will end up on the user's screen. The total process to convert coordinates within a specified range to NDC that can easily be mapped to 2D view-space coordinates is called **projection** since the projection matrix **projects** 3D coordinates to the easy-to-map-to-2D normalized device coordinates.

Once all the vertices are transformed to clip space a final operation called **perspective division** is performed where we divide the x , y and z components of the position vectors by the vector's homogeneous w component; perspective division is what transforms the 4D clip space coordinates to 3D normalized device coordinates. This step is performed automatically at the end of each vertex shader run.

It is after this stage where the resulting coordinates are mapped to screen coordinates (using the settings of `glViewport`) and turned into fragments.

The projection matrix to transform view coordinates to clip coordinates can take two different forms, where each form defines its own unique frustum. We can either create an **orthographic** projection matrix or a **perspective** projection matrix.

9.5.1 Orthographic projection

An orthographic projection matrix defines a cube-like frustum box that defines the clipping space where each vertex outside this box is clipped. When creating an orthographic projection matrix we specify the width, height and length of the visible frustum. All the coordinates that end up inside this frustum after transforming them to clip space with the orthographic projection matrix won't be clipped. The frustum looks a bit like a container:

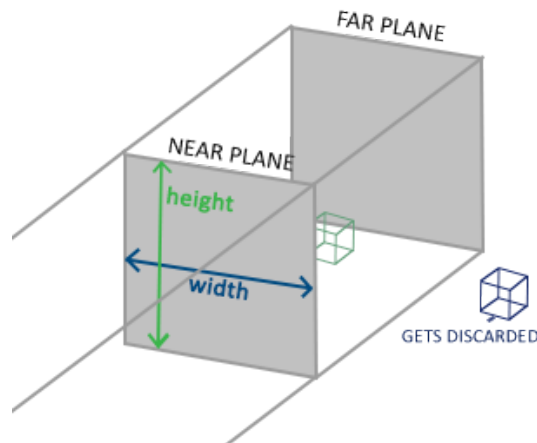

The frustum defines the visible coordinates and is specified by a width, a height and a **near** and **far** plane. Any coordinate in front of the near plane is clipped and the same applies to coordinates behind the far plane. The orthographic frustum directly maps all coordinates inside the frustum to normalized device coordinates since the w component of each vector is untouched; if the w component is equal to 1.0 perspective division doesn't change the coordinates.

To create an orthographic projection matrix we make use of GLM's built-in function `glm::ortho`:

```
glm::ortho(0.0f, 800.0f, 0.0f, 600.0f, 0.1f, 100.0f);
```

The first two parameters specify the left and right coordinate of the frustum and the third and fourth parameter specify the bottom and top part of the frustum. With those 4 points we've defined the size of the near and far planes and the 5th and 6th parameter then define the distances between the near and far plane. This specific projection matrix transforms all coordinates between these x , y and z range values to normalized device coordinates.

An orthographic projection matrix directly maps coordinates to the 2D plane that is your screen, but in reality a direct projection produces unrealistic results since the projection doesn't take **perspective** into account. That is something the **perspective projection** matrix fixes for us.

9.5.2 Perspective projection

If you ever were to enjoy the graphics the *real life* has to offer you'll notice that objects that are farther away appear much smaller. This weird effect is something we call **perspective** and it happens because we see the world from two different viewports: one eye each. Perspective is especially noticeable when looking down the end of an infinite motorway or railway as seen in the following image:

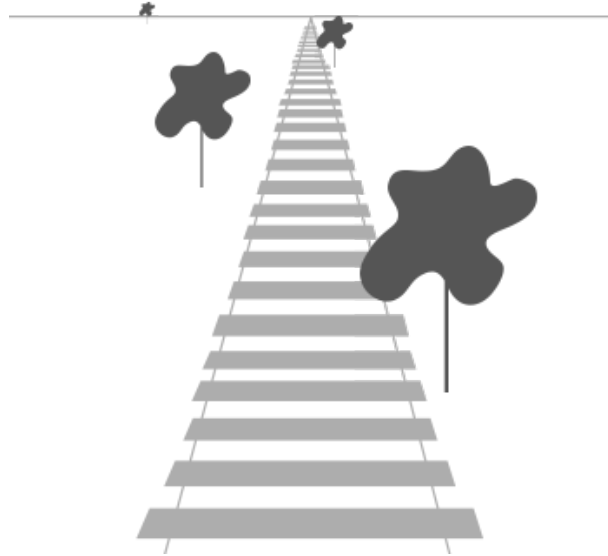

As you can see, due to perspective the lines seem to coincide the farther they're away. This is exactly the effect perspective projection tries to mimic and it does so using a [perspective projection matrix](#). The projection matrix maps a given frustum range to clip space, but also manipulates the w value of each vertex coordinate in such a way that the further away a vertex coordinate is from the viewer, the higher this w component becomes. Once the coordinates are transformed to clip space they are in the range $-w$ to w (anything outside this range is clipped). OpenGL requires that the visible coordinates fall between the range -1.0 and 1.0 as the final vertex shader output, thus once the coordinates are in clip space, perspective division is applied to the clip space coordinates:

$$out = \begin{pmatrix} x/w \\ y/w \\ z/w \end{pmatrix}$$

Each component of the vertex coordinate is divided by its w component giving smaller vertex coordinates the further away a vertex is from the viewer. This is another reason why the w component is important, since it helps us with perspective projection. The resulting coordinates are then in normalized device space. If you're interested to figure out how the orthographic and perspective projection matrices are actually calculated (and aren't too scared of mathematics) I can recommend [this excellent article](#) by Songho.

A perspective projection matrix can be created in GLM as follows:

```
glm::mat4 proj = glm::perspective(45.0f, (float)width/(float)height, 0.1f,
    100.0f);
```

What `glm::perspective` does is again create a large *frustum* that defines the visible space, anything outside the frustum will not end up in the clip space volume and will thus become clipped. A perspective frustum can be visualized as a non-uniformly shaped box from where each coordinate inside this box will be mapped to a point in clip space. An image of a perspective frustum is seen below:

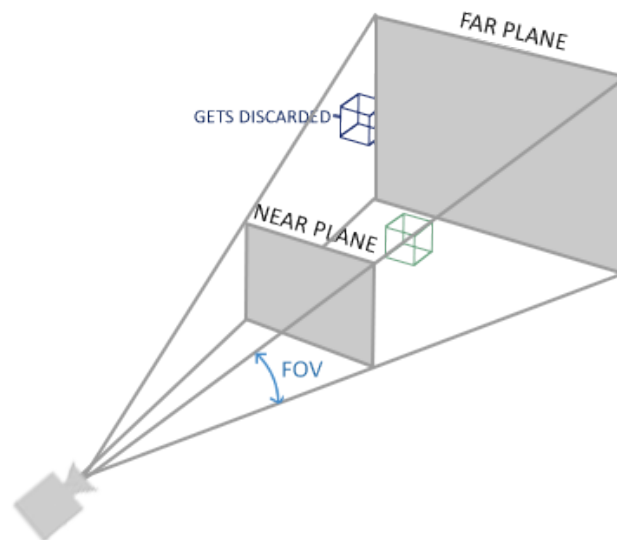

Its first parameter defines the *fov* value, that stands for *field of view* and sets how large the viewport is. For a realistic view it is usually set at $45.0f$, but for more doom-style results you could set it to a higher value. The second parameter sets the aspect ratio which is calculated by dividing the viewport's width by its height. The third and fourth parameter set the *near* and *far* plane of the frustum. We usually set the near distance to $0.1f$ and the far distance to $100.0f$. All the vertices between the near and far plane and inside the frustum will be rendered.

Whenever the *near* value of your perspective matrix is set a bit too high (like $10.0f$), OpenGL will clip all coordinates close to the camera (between $0.0f$ and $10.0f$), which gives a familiar visual result in videogames in that you can see through certain objects if you move too close to them.

When using orthographic projection, each of the vertex coordinates are directly mapped to clip space without any fancy perspective division (it still does perspective division, but the w component is not manipulated (it stays 1) and thus has no effect). Because the orthographic projection doesn't use perspective projection, objects farther away do not seem smaller, which produces a weird visual output. For this reason the orthographic projection is mainly used for 2D renderings and for some architectural or engineering applications where we'd rather not have vertices distorted by perspective. Applications like *Blender* that are used for 3D modelling sometimes use orthographic projection for modelling, because it more accurately depicts each object's dimensions. Below you'll see a comparison of both projection methods in Blender:

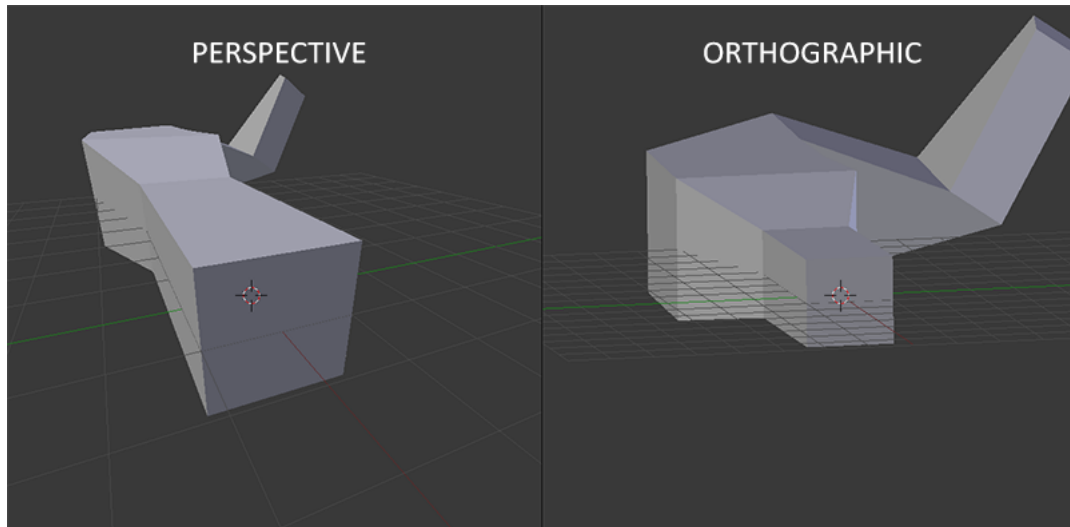

You can see that with perspective projection, the vertices farther away appear much smaller, while in orthographic projection each vertex has the same distance to the user.

9.6 Putting it all together

We create a transformation matrix for each of the aforementioned steps: model, view and projection matrix. A vertex coordinate is then transformed to clip coordinates as follows:

$$V_{clip} = M_{projection} \cdot M_{view} \cdot M_{model} \cdot V_{local}$$

Note that the order of matrix multiplication is reversed (remember that we need to read matrix multiplication from right to left). The resulting vertex should then be assigned to `gl_Position` in the vertex shader and OpenGL will then automatically perform perspective division and clipping.

And then?

The output of the vertex shader requires the coordinates to be in clip-space which is what we just did with the transformation matrices. OpenGL then performs *perspective division* on the *clip-space coordinates* to transform them to *normalized-device coordinates*. OpenGL then uses the parameters from `glViewport` to map the normalized-device coordinates to *screen coordinates* where each coordinate corresponds to a point on your screen (in our case a 800x600 screen). This process is called the *viewport transform*.

This is a difficult topic to understand so if you're still not exactly sure about what each space is used for you don't have to worry. Below you'll see how we can actually put these coordinate spaces to good use and enough examples will follow in these tutorials.

9.7 Going 3D

Now that we know how to transform 3D coordinates to 2D coordinates we can start showing our objects as real 3D objects instead of a lame 2D plane we've been showing so far.

To start drawing in 3D we'll first create a model matrix. The model matrix consists of translations, scaling and/or rotations we'd like to apply to *transform* all object's vertices it to the global world space. Let's transform our plane a bit by rotating it on the x-axis so it looks like it's laying on the floor. The model matrix then looks like this:

```
glm::mat4 model;  
model = glm::rotate(model, -55.0f, glm::vec3(1.0f, 0.0f, 0.0f));
```

By multiplying the vertex coordinates with this model matrix we're transforming the vertex coordinates to world coordinates. Our plane that is slightly on the floor thus represents the plane in the global world.

Next we need to create a view matrix. We want to move slightly backwards in the scene so the object becomes visible (when in world space we're located at the origin $(0, 0, 0)$). To move around the scene, think about the following:

- To move a camera backwards, is the same as moving the entire scene forward.

That is exactly what a view matrix does, we move the entire scene around inversed to where we want the camera to move.

Because we want to move backwards and since OpenGL is a right-handed system we have to move in the positive z-axis. We do this by translating the scene towards the negative z-axis. This gives the impression that we are moving backwards.

Right-handed system

By convention, OpenGL is a right-handed system. What this basically says is that the positive x-axis is to your right, the positive y-axis is up and the positive z-axis is backwards. Think of your screen being the center of the 3 axes and the positive z-axis going through your screen towards you. The axes are drawn as follows:

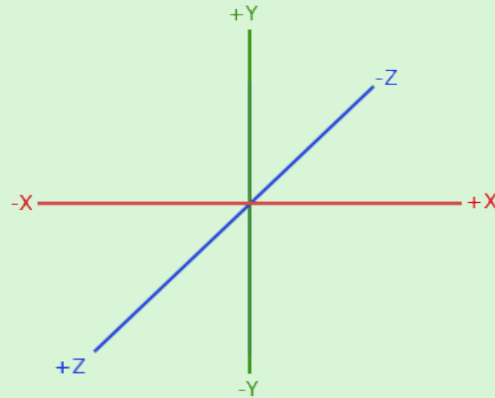

To understand why it's called right-handed do the following:

- Stretch your right-arm along the positive y-axis with your hand up top.
- Let your thumb point to the right.
- Let your pointing finger point up.
- Now bend your middle finger downwards 90 degrees.

If you did things right, your thumb should point towards the positive x-axis, the pointing finger towards the positive y-axis and your middle finger towards the positive z-axis. If you were to do this with your left-arm you would see the z-axis is reversed. This is known as a left-handed system and is commonly used by DirectX. Note that in normalized device coordinates OpenGL actually uses a left-handed system (the projection matrix switches the handedness).

We'll discuss how to move around the scene in more detail in the next tutorial. For now the view matrix looks like this:

```
glm::mat4 view;
// Note that we're translating the scene in the reverse direction of where
// we want to move
view = glm::translate(view, glm::vec3(0.0f, 0.0f, -3.0f));
```

The last thing we need to define is the projection matrix. We want to use perspective projection for our scene so we'll declare the projection matrix like this:

```
glm::mat4 projection;
projection = glm::perspective(45.0f, screenWidth / screenHeight, 0.1f,
    100.0f);
```

Again, be careful when specifying degrees in glm. Here we set the fov parameter to 45 degrees, but some implementations of GLM take the fov in radians in which case you need to set it as `glm::radians(45.0)`.

Now that we created the transformation matrices we should pass them to our shaders. First let's declare the transformation matrices as uniforms in the vertex shader and multiply them with the vertex coordinates:

```
#version 330 core
layout (location = 0) in vec3 position;
...
uniform mat4 model;
uniform mat4 view;
uniform mat4 projection;

void main()
{
    // Note that we read the multiplication from right to left
    gl_Position = projection * view * model * vec4(position, 1.0f);
    ...
}
```

We should also send the matrices to the shader (this is usually done each render iteration since transformation matrices tend to change a lot):

```
GLint modelLoc = glGetUniformLocation(ourShader.Program, "model");
glUniformMatrix4fv(modelLoc, 1, GL_FALSE, glm::value_ptr(model));
... // Same for View Matrix and Projection Matrix
```

Now that our vertex coordinates are transformed via the model, view and projection matrix the final object should be:

- Tilted backwards to the floor.
- A bit farther away from us.
- Be displayed with perspective (it should get smaller, the further its vertices are).

Let's check if the result actually does fulfill these requirements:

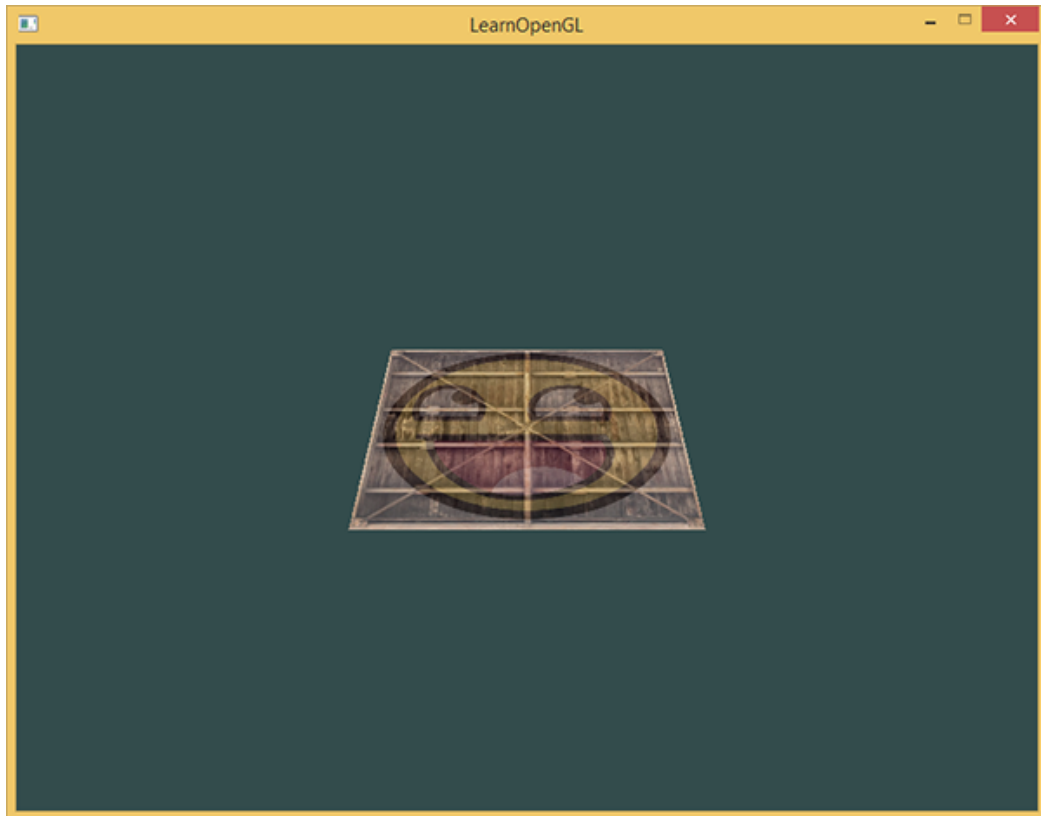

It does indeed look like the plane is a 3D plane that's resting at some imaginary floor. If you're not getting the same result check the complete [source code](#) and the [vertex](#) and [fragment](#) shader.

9.8 More 3D

So far we've been working with a 2D plane, even in 3D space, so let's take the adventurous route and extend our 2D plane to a 3D cube. To render a cube we need a total of 36 vertices (6 faces * 2 triangles * 3 vertices each). 36 vertices are a lot to sum up so you can retrieve them from [here](#). Note that we're omitting the color values, since we'll only be using textures to get the final color value.

For fun, we'll let the cube rotate over time:

```
model = glm::rotate(model, (GLfloat)glfwGetTime() * 50.0f, glm::vec3(0.5f, 1.0f, 0.0f));
```

And then we'll draw the cube using `glDrawArrays`, but this time with a count of 36 vertices.

```
glDrawArrays(GL_TRIANGLES, 0, 36);
```

You should get something similar to the following:

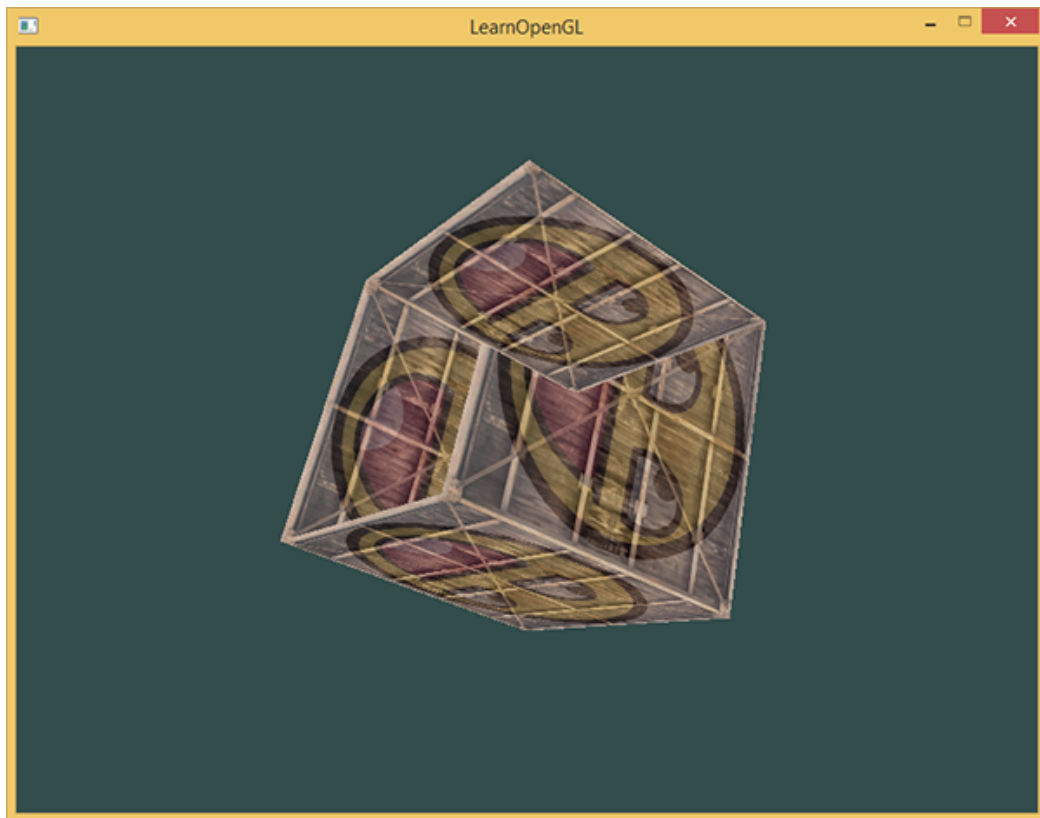

It does resemble a cube slightly but something's off. Some sides of the cubes are being drawn over other sides of the cube. This happens because when OpenGL draws your cube triangle-by-triangle, it will overwrite its pixels even though something else might've been drawn there before. Because of this, some triangles are drawn on top of each other while they're not supposed to overlap.

Luckily, OpenGL stores depth information in a buffer called the **z-buffer** that allows OpenGL to decide when to draw over a pixel and when not to. Using the z-buffer we can configure OpenGL to do depth-testing.

9.8.1 Z-buffer

OpenGL stores all its depth information in a z-buffer, also known as a **depth buffer**. GLFW automatically creates such a buffer for you (just like it has a color-buffer that stores the colors of the output image). The depth is stored within each fragment (as the fragment's z value) and whenever the fragment wants to output its color, OpenGL compares its depth values with the z-buffer and if the current fragment is behind the other fragment it is discarded, otherwise overwritten. This process is called **depth testing** and is done automatically by OpenGL.

However, if we want to make sure OpenGL actually performs the depth testing we first need to tell OpenGL we want to enable depth testing; it is disabled by default. We can enable depth testing using `glEnable`. The `glEnable` and `glDisable` functions allow us to enable/disable certain functionality in OpenGL. That functionality is then enabled/disabled until another call is made to disable/enable it. Right now we want to enable depth testing by enabling `GL_DEPTH_TEST`:

```
glEnable(GL_DEPTH_TEST);
```

Since we're using a depth buffer we also want to clear the depth buffer before each render iteration (otherwise the depth information of the previous frame stays in the buffer). Just like clearing the color buffer, we can clear the depth buffer by specifying the `DEPTH_BUFFER_BIT` bit in the `glClear` function:

```
glClear(GL_COLOR_BUFFER_BIT | GL_DEPTH_BUFFER_BIT);
```

Let's re-run our program and see if OpenGL now performs depth testing:

See video online

There we go! A fully textured cube with proper depth testing that rotates over time. Check the source code [here](#).

9.8.2 More cubes!

Say we wanted to display 10 of our cubes on screen. Each cube will look the same but will only differ in where it's located in the world with each a different rotation. The graphical layout of the cube is already defined so we don't have to change our buffers or attribute arrays when rendering more objects. The only thing we have to change for each object is its model matrix where we transform the cubes into the world.

First, let's define a translation vector for each cube that specifies its position in world space. We'll define 10 cube positions in a `glm::vec3` array:

```
glm::vec3 cubePositions[] = {
    glm::vec3( 0.0f, 0.0f, 0.0f),
    glm::vec3( 2.0f, 5.0f, -15.0f),
    glm::vec3(-1.5f, -2.2f, -2.5f),
    glm::vec3(-3.8f, -2.0f, -12.3f),
    glm::vec3( 2.4f, -0.4f, -3.5f),
    glm::vec3(-1.7f, 3.0f, -7.5f),
    glm::vec3( 1.3f, -2.0f, -2.5f),
    glm::vec3( 1.5f, 2.0f, -2.5f),
    glm::vec3( 1.5f, 0.2f, -1.5f),
    glm::vec3(-1.3f, 1.0f, -1.5f)
};
```

Now, within the game loop we want to call the `glDrawArrays` function 10 times, but this time send a different model matrix to the vertex shader each time before we render. We will create a small loop within the game loop that renders our object 10 times with a different model matrix. Note that we also add a small rotation to each container.

```
glBindVertexArray(VAO);
for(GLuint i = 0; i < 10; i++)
{
    glm::mat4 model;
    model = glm::translate(model, cubePositions[i]);
    GLfloat angle = 20.0f * i;
    model = glm::rotate(model, angle, glm::vec3(1.0f, 0.3f, 0.5f));
```

```
glUniformMatrix4fv(modelLoc, 1, GL_FALSE, glm::value_ptr(model));  
  
glDrawArrays(GL_TRIANGLES, 0, 36);  
}  
glBindVertexArray(0);
```

This snippet of code will update the model matrix each time a new cube is drawn and do this 10 times in total. Right now we should be looking into a world filled with 10 oddly rotated cubes:



Perfect! It looks like our container found some likeminded friends. If you're stuck see if you can compare your code with the [source code](#) and the [vertex](#) and [fragment](#) shader before continuing.

9.9 Exercises

- Try experimenting with the `FoV` and `aspect-ratio` parameters of GLM's `projection` function. See if you can figure out how those affect the perspective frustum.
- Play with the view matrix by translating in several directions and see how the scene changes. Think of the view matrix as a camera object.
- Try to make every 3rd container (including the 1st) rotate over time, while leaving the other containers static using just the model matrix: [solution](#).

10. Camera

In the previous tutorial we discussed the view matrix and how we can use the view matrix to move around the scene (we moved backwards a little). OpenGL by itself is not familiar with the concept of a *camera*, but we can try to simulate one by moving all objects in the scene in the reverse direction, giving the illusion that **we** are moving.

In this tutorial we'll discuss how we can set up a camera in OpenGL. We will discuss an FPS-style camera that allows you to freely move around in a 3D scene. In this tutorial we'll also discuss keyboard and mouse input and finish with a custom camera class.

10.1 Camera/View space

When we're talking about camera/view space we're talking about all the vertex coordinates as seen from the camera's perspective as the origin of the scene: the view matrix transforms all the world coordinates into view coordinates that are relative to the camera's position and direction. To define a camera we need its position in world space, the direction it's looking at, a vector pointing to the right and a vector pointing upwards from the camera. A careful reader might notice that we're actually going to create a coordinate system with 3 perpendicular unit axes with the camera's position as the origin.

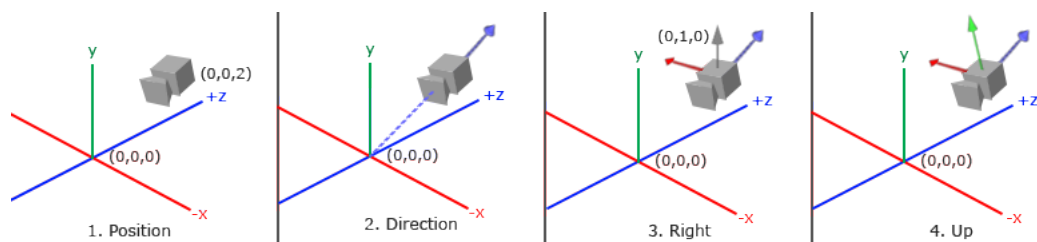

10.1.1 1. Camera position

Getting a camera position is easy. The camera position is basically a vector in world space that points to the camera's position. We set the camera at the same position we've set the camera in the previous tutorial:

```
glm::vec3 cameraPos = glm::vec3(0.0f, 0.0f, 3.0f);
```

Don't forget that the positive z-axis is going through your screen towards you so if we want the camera to move backwards, we move along the positive z-axis.

10.1.2 2. Camera direction

The next vector required is the camera's direction e.g. at what direction it is pointing at. For now we let the camera point to the origin of our scene: $(0, 0, 0)$. Remember that if we subtract two vectors from each other we get a vector that's the difference of these two vectors? Subtracting the camera position vector from the scene's origin vector thus results in the direction vector. Since we know that the camera points towards the negative z direction we want the direction vector to point towards the camera's positive z-axis. If we switch the subtraction order around we now get a vector pointing towards the camera's positive z-axis:

```
glm::vec3 cameraTarget = glm::vec3(0.0f, 0.0f, 0.0f);  
glm::vec3 cameraDirection = glm::normalize(cameraPos - cameraTarget);
```

The name *direction* vector is not the best chosen name, since it is actually pointing in the reverse direction of what it is targeting.

10.1.3 3. Right axis

The next vector that we need is a *right* vector that represents the positive x-axis of the camera space. To get the *right* vector we use a little trick by first specifying an *up* vector that points upwards (in world space). Then we do a cross product on the up vector and the direction vector from step 2. Since the result of a cross product is a vector perpendicular to both vectors, we will get a vector that points in the positive x-axis's direction (if we would switch the vectors we'd get a vector that points in the negative x-axis):

```
glm::vec3 up = glm::vec3(0.0f, 1.0f, 0.0f);  
glm::vec3 cameraRight = glm::normalize(glm::cross(up, cameraDirection));
```

10.1.4 4. Up axis

Now that we have both the x-axis vector and the z-axis vector, retrieving the vector that points in the camera's positive y-axis is relatively easy: we take the cross product of the right and direction vector:

```
glm::vec3 cameraUp = glm::cross(cameraDirection, cameraRight);
```

With the help of the cross product and a few tricks we were able to create all the vectors that form the view/camera space. For the more mathematically inclined readers, this process is known as the [Gram-Schmidt](#) process in linear algebra. Using these camera vectors we can now create a [LookAt](#) matrix that proves very useful for creating a camera.

10.2 Look At

A great thing about matrices is that if you define a coordinate space using 3 perpendicular (or non-linear) axes you can create a matrix with those 3 axes plus a translation vector and you can transform any vector to that coordinate space by multiplying it with this matrix. This is exactly what the *LookAt* matrix does and now that we have 3 perpendicular axes and a position vector to define the camera space we can create our own LookAt matrix:

$$LookAt = \begin{bmatrix} R_x & R_y & R_z & 0 \\ U_x & U_y & U_z & 0 \\ D_x & D_y & D_z & 0 \\ 0 & 0 & 0 & 1 \end{bmatrix} * \begin{bmatrix} 1 & 0 & 0 & -P_x \\ 0 & 1 & 0 & -P_y \\ 0 & 0 & 1 & -P_z \\ 0 & 0 & 0 & 1 \end{bmatrix}$$

Where R is the right vector, U is the up vector, D is the direction vector and P is the camera's position vector. Note that the position vector is inverted since we eventually want to translate the world in the opposite direction of where we want to move. Using this LookAt matrix as our view matrix effectively transforms all the world coordinates to the view space we just defined. The LookAt matrix then does exactly what it says: it creates a view matrix that *looks* at a given target.

Luckily for us, GLM already does all this work for us. We only have to specify a camera position, a target position and a vector that represents the up vector in world space (the up vector we used for calculating the right vector). GLM then creates the LookAt matrix that we can use as our view matrix:

```
glm::mat4 view;
view = glm::lookAt(glm::vec3(0.0f, 0.0f, 3.0f),
                  glm::vec3(0.0f, 0.0f, 0.0f),
                  glm::vec3(0.0f, 1.0f, 0.0f));
```

The `glm::LookAt` function requires a position, target and up vector respectively. This creates a view matrix that is the same as the one used in the previous tutorial.

Before delving into user input, let's get a little funky first by rotating the camera around our scene. We keep the target of the scene at $(0, 0, 0)$.

We use a little bit of trigonometry to create an x and z coordinate each frame that represents a point on a circle and we'll use these for our camera position. By re-calculating the x and y coordinate we're traversing all the points in a circle and thus the camera rotates around the scene. We enlarge this circle by a pre-defined `radius` and create a new view matrix each render iteration using GLFW's `glfwGetTime` function:

```
GLfloat radius = 10.0f;
GLfloat camX = sin(glfwGetTime()) * radius;
GLfloat camZ = cos(glfwGetTime()) * radius;
```



```
glm::mat4 view;  
view = glm::lookAt(glm::vec3(camX, 0.0, camZ), glm::vec3(0.0, 0.0, 0.0),  
    glm::vec3(0.0, 1.0, 0.0));
```

If you run this code you should get something like this:

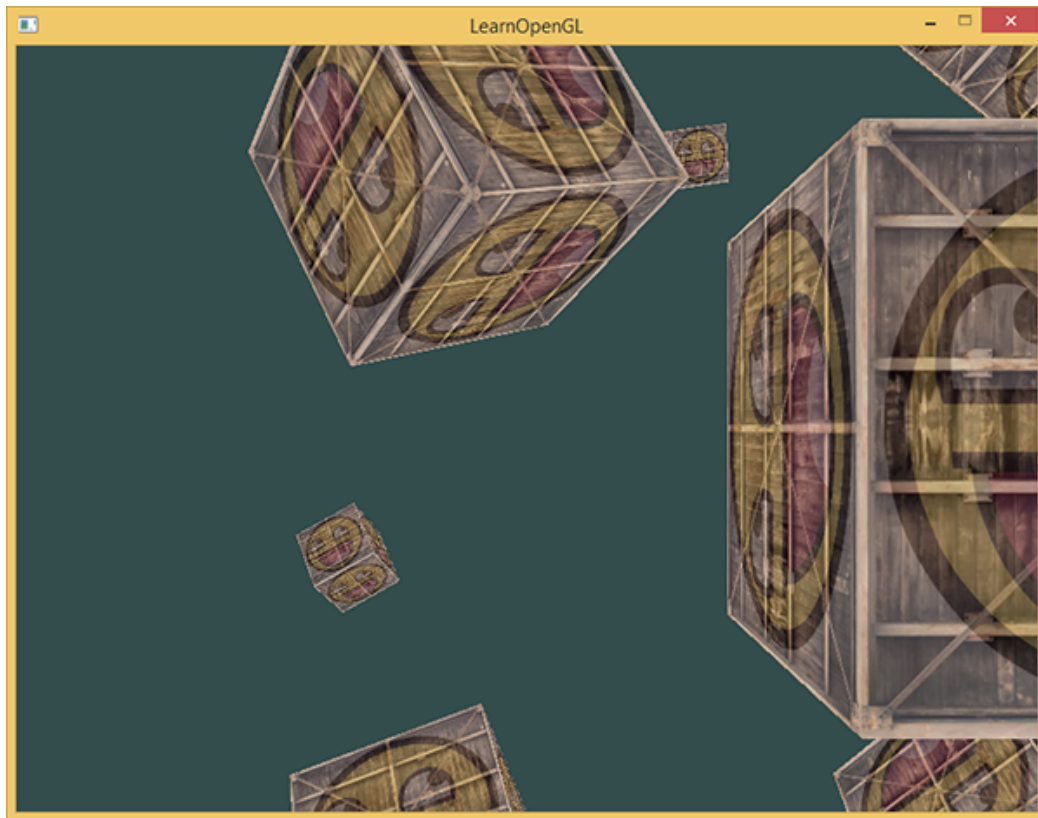

With this little snippet of code the camera now circles around the scene over time. Feel free to experiment with the radius and position/direction parameters to get the feel of how this *LookAt* matrix works. Also, check the [source code](#) and the [vertex](#) and [fragment](#) shader if you're stuck.

10.3 Walk around

Swinging the camera around a scene is fun, but it's more fun to do all the movement by ourselves! First we need to set up a camera system, so it is useful to define some camera variables at the top of our program:

```
glm::vec3 cameraPos = glm::vec3(0.0f, 0.0f, 3.0f);  
glm::vec3 cameraFront = glm::vec3(0.0f, 0.0f, -1.0f);  
glm::vec3 cameraUp = glm::vec3(0.0f, 1.0f, 0.0f);
```

The *LookAt* function now becomes:

```
view = glm::lookAt(cameraPos, cameraPos + cameraFront, cameraUp);
```

First we set the camera position to the previously defined `cameraPos`. The direction is the current position + the direction vector we just defined. This ensures that however we move, the

camera keeps looking at the target direction. Let's play a bit with these variables by updating the `cameraPos` vector when we press some keys.

We already defined a `key_callback` function for GLFW's keyboard input so let's add some new key commands to check for:

```
void key_callback(GLFWwindow* window, int key, int scancode, int action,
                 int mode)
{
    ...
    GLfloat cameraSpeed = 0.05f;
    if(key == GLFW_KEY_W)
        cameraPos += cameraSpeed * cameraFront;
    if(key == GLFW_KEY_S)
        cameraPos -= cameraSpeed * cameraFront;
    if(key == GLFW_KEY_A)
        cameraPos -= glm::normalize(glm::cross(cameraFront, cameraUp)) *
        cameraSpeed;
    if(key == GLFW_KEY_D)
        cameraPos += glm::normalize(glm::cross(cameraFront, cameraUp)) *
        cameraSpeed;
}
```

Whenever we press one of the WASD keys the camera's position is updated accordingly. If we want to move forward or backwards we add or subtract the direction vector from the position vector. If we want to move sideways we do a cross product to create a *right* vector and we move along the right vector accordingly. This creates the familiar *strafe* effect when using the camera.

Note that we normalize the resulting *right* vector. If we wouldn't normalize this vector, the resulting cross product might return differently sized vectors based on the `cameraFront` variable. If we would not normalize the vector we would either move slow or fast based on the camera's orientation instead of at a consistent movement speed.

If you update the `key_callback` function with this code fragment you are able to move along the scene by going forward/backwards or sideways.

See video online

After fiddling around with this basic camera system you probably noticed that you can't move in two directions at the same time (diagonal movement) and when you hold down one of the keys, it first bumps a little and after a short break starts moving. This happens because most event-input systems can handle only one keypress at a time and their functions are only called whenever we activate a key. While this works for most GUI systems, it is not very practical for smooth camera movement. We can solve the issue by showing you a little trick.

The trick is to only keep track of what keys are pressed/released in the callback function. In the game loop we then read these values to check what keys are *active* and react accordingly. So we're basically storing state information about what keys are pressed/released and react upon that state in the game loop. First, let's create a boolean array representing the keys pressed/released:

```
bool keys[1024];
```

We then have to set the pressed/released keys to `true` or `false` in the `key_callback` function:

```
if(action == GLFW_PRESS)
    keys[key] = true;
else if(action == GLFW_RELEASE)
    keys[key] = false;
```

And let's create a new function that we call `do_movement` where we update the camera values based on the keys that were pressed:

```
void do_movement()
{
    // Camera controls
    GLfloat cameraSpeed = 0.01f;
    if(keys[GLFW_KEY_W])
        cameraPos += cameraSpeed * cameraFront;
    if(keys[GLFW_KEY_S])
        cameraPos -= cameraSpeed * cameraFront;
    if(keys[GLFW_KEY_A])
        cameraPos -= glm::normalize(glm::cross(cameraFront, cameraUp)) *
            cameraSpeed;
    if(keys[GLFW_KEY_D])
        cameraPos += glm::normalize(glm::cross(cameraFront, cameraUp)) *
            cameraSpeed;
}
```

The code from the previous section is now moved to the `Do_Movement` function. Because all GLFW's key-enums are basically just integers, we can use them to index the array.

Last, but not least, we need to add a call to the new function in the game loop:

```
while(!glfwWindowShouldClose(window))
{
    // Check and call events
    glfwPollEvents();
    do_movement();

    // Render stuff
    ...
}
```

By now, you should be able to move in both directions at the same time and you should be able to move instantaneously even while holding down the keys. Feel free to check the [source code](#) if you're stuck.

10.4 Movement speed

Currently we used a constant value for movement speed when walking around. In theory this seems fine, but in practice people have different processing powers and the result of that is that some people are able to draw much more frames than others each second. Whenever a user draws more

frames than another user he also calls `do_movement` more often. The result is that some people move really fast and some really slow depending on their setup. When shipping your application you want to make sure it runs the same on all kinds of hardware.

Graphics applications and games usually keep track of a `deltaTime` variable that stores the time it takes to render the last frame. We then multiply all velocities with this `deltaTime` value. The result is that when we have a large `deltaTime` in a frame, meaning that the last frame took longer than average, the velocity for that frame will also be a bit higher to balance it all out. When using this approach it does not matter if you have a very fast or slow pc, the velocity of the camera will be balanced out accordingly so each user will have the same experience.

To calculate the `deltaTime` value we keep track of 2 global variables:

```
GLfloat deltaTime = 0.0f;    // Time between current frame and last frame
GLfloat lastFrame = 0.0f;    // Time of last frame
```

Within each frame we then calculate the new `deltaTime` value for later use:

```
GLfloat currentFrame = glfwGetTime();
deltaTime = currentFrame - lastFrame;
lastFrame = currentFrame;
```

Now that we have `deltaTime` we can take it into account when calculating the velocities:

```
void Do_Movement ()
{
    GLfloat cameraSpeed = 5.0f * deltaTime;
    ...
}
```

Together with the previous section we should now have a much smoother and more consistent camera system for moving around the scene:

See video online

And now we have a camera that walks and looks equally fast on any system. Again, check the [source code](#) if you're stuck. We'll see the `deltaTime` value frequently return with anything movement related.

10.5 Look around

Only using the keyboard keys to move around isn't that interesting. Especially since we can't turn around making the movement rather restricted. That's where the mouse comes in!

To look around the scene we have to change the `cameraFront` vector based on the input of the mouse. However, changing the direction vector based on mouse rotations is a little complicated and requires some trigonometry. If you do not understand the trigonometry, don't worry. You can just skip to the code sections and paste them in your code; you can always come back later if you want to know more.

10.6 Euler angles

Euler angles are 3 values that can represent any rotation in 3D, defined by Leonhard Euler somewhere in the 1700s. There are 3 Euler angles: *pitch*, *yaw* and *roll*. The following image gives them a visual meaning:

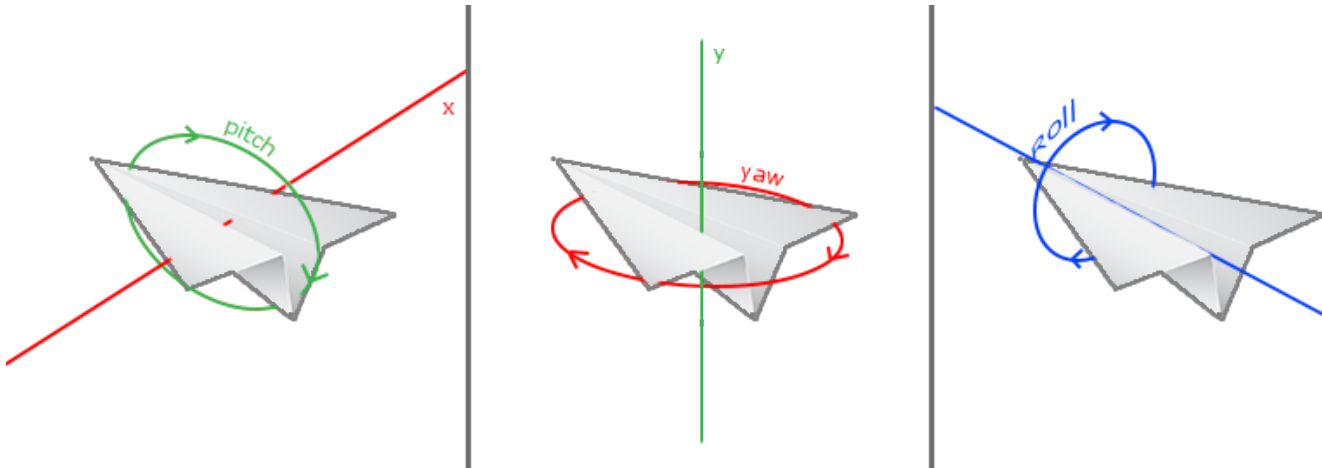

The **pitch** is the angle that depicts how much we're looking up or down as seen in the first image. The second image shows the **yaw** value which represents the magnitude we're looking to the left or to the right. The **roll** represents how much we *roll* as mostly used in space-flight cameras. Each of the Euler angles are represented by a single value and with the combination of all 3 of them we can calculate any rotation vector in 3D.

For our camera system we only care about the yaw and pitch values so we won't discuss the roll value here. Given a pitch and a yaw value we can convert them into a 3D vector that represents a new direction vector. The process of converting yaw and pitch values to a direction vector requires a bit of trigonometry and we start with a basic case:

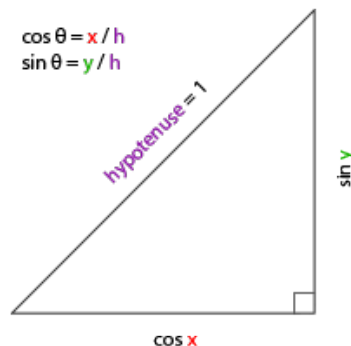

If we define the hypotenuse to be of length 1 we know from trigonometry (soh cah toa) that the adjacent side's length is $\cos x/h = \cos x/1 = \cos x$ and that the opposing side's length is $\sin y/h = \sin y/1 = \sin y$. This gives us some general formulas for retrieving the length in both the x and y directions, depending on the given angle. Let's use this to calculate the components of the direction vector:

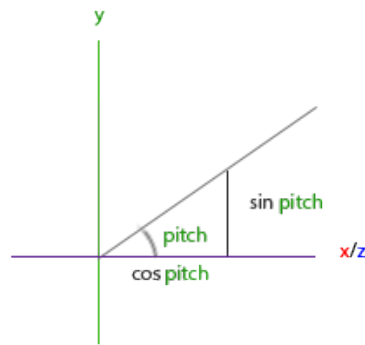

This triangle looks similar to the previous triangle so if we visualize that we are sitting on the xz plane and look towards the y axis we can calculate the length / strength of the y direction (how much we're looking up or down) based on the first triangle. From the image we can see that the resulting y value for a given pitch equals $\sin \theta$:

```
direction.y = sin(glm::radians(pitch)); // Note that we convert the angle
to radians first
```

Here we only update the y value is affected, but if you look carefully you can also that the x and z components are affected. From the triangle we can see that their values equal:

```
direction.x = cos(glm::radians(pitch));
direction.z = cos(glm::radians(pitch));
```

Let's see if we can find the required components for the yaw value as well:

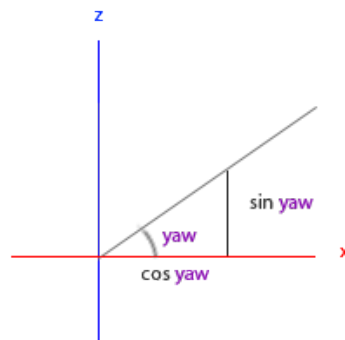

Just like the pitch triangle we can see that the x component depends on the $\cos(\text{yaw})$ value and the z value also depends on the \sin of the yaw value. Adding this to the previous values results in a final direction vector based on the pitch and yaw values:

```
direction.x = cos(glm::radians(pitch)) * cos(glm::radians(yaw));
direction.y = sin(glm::radians(pitch));
direction.z = cos(glm::radians(pitch)) * sin(glm::radians(yaw));
```

This gives us a formula to convert yaw and pitch values to a 3-dimensional direction vector that we can use for looking around. You probably wondered by now: how do we get these yaw and pitch values?

10.7 Mouse input

The yaw and pitch values are obtained from mouse (or controller/joystick) movement where horizontal mouse-movement affects the yaw and vertical mouse-movement affects the pitch. The idea is to store the last frame's mouse positions and in the current frame we calculate how much the mouse values changed in comparison with last frame's value. The higher the horizontal/vertical difference, the more we update the pitch or yaw value and thus the more the camera should move.

First we will tell GLFW that it should hide the cursor and **capture** it. Capturing a cursor means that once the application has focus the mouse cursor stays within the window (unless the application loses focus or quits). We can do this with one simple configuration call:

```
glfwSetInputMode(window, GLFW_CURSOR, GLFW_CURSOR_DISABLED);
```

After this call, wherever we move the mouse it won't be visible and it should not leave the window. This is perfect for an FPS camera system.

To calculate the pitch and yaw values we need to tell GLFW to listen to mouse-movement events. We do this (similar to keyboard input) by creating a callback function with the following prototype:

```
void mouse_callback(GLFWwindow* window, double xpos, double ypos);
```

Here `xpos` and `ypos` represent the current mouse positions. As soon as we register the callback function with GLFW each time the mouse moves, the `mouse_callback` function is called:

```
glfwSetCursorPosCallback(window, mouse_callback);
```

When handling mouse input for an FPS style camera there are several steps we have to take before eventually retrieving the direction vector:

1. Calculate the mouse's offset since the last frame.
2. Add the offset values to the camera's yaw and pitch values.
3. Add some constraints to the maximum/minimum yaw/pitch values
4. Calculate the direction vector

The first step is to calculate the offset of the mouse since the last frame. We first have to store the last mouse positions in the application, which we set to the center of the screen (screen size is 800 by 600) initially:

```
GLfloat lastX = 400, lastY = 300;
```

Then in the mouse's callback function we calculate the offset movement between the last and current frame:

```
GLfloat xoffset = xpos - lastX;  
GLfloat yoffset = lastY - ypos; // Reversed since y-coordinates range from  
    bottom to top  
lastX = xpos;  
lastY = ypos;
```

```
GLfloat sensitivity = 0.05f;
xoffset *= sensitivity;
yoffset *= sensitivity;
```

Note that we multiply the offset values by a `sensitivity` value. If we omit this multiplication the mouse movement would be way too strong; fiddle around with the sensitivity value to your liking.

Next we add the offset values to globally declared `pitch` and `yaw` values:

```
yaw += xoffset;
pitch += yoffset;
```

In the third step we'd like to add some constraints to the camera so users won't be able to make weird camera movements (also prevents a few weird issues). The pitch will be constrained in such a way that users won't be able to look higher than 89 degrees (at 90 degrees the view tends to reverse, so we stick to 89 as our limit) and also not below -89 degrees. This ensures the user will be able to look up to the sky and down to his feet but not further. The constraint works by just replacing the resulting value with its constraint value whenever it breaches the constraint:

```
if(pitch > 89.0f)
pitch = 89.0f;
if(pitch < -89.0f)
pitch = -89.0f;
```

Note that we set no constraint on the yaw value since we don't want to constrain the user in horizontal rotation. However, it's just as easy to add a constraint to the yaw as well if you feel like it.

The fourth and last step is to calculate the actual direction vector from the resulting yaw and pitch value as discussed in the previous section:

```
glm::vec3 front;
front.x = cos(glm::radians(pitch)) * cos(glm::radians(yaw));
front.y = sin(glm::radians(pitch));
front.z = cos(glm::radians(pitch)) * sin(glm::radians(yaw));
cameraFront = glm::normalize(front);
```

This computed direction vector then contains all the rotations calculated from the mouse's movement. Since the `cameraFront` vector is already included in glm's `lookAt` function we're set to go.

If you would now run the code you will notice that the camera makes a large sudden jump whenever the window first receives focus of your mouse cursor. The cause for the sudden jump is that as soon as your cursor enters the window the mouse callback function is called with an `xpos` and `ypos` position equal to the location your mouse entered the screen. This is usually a position that is quite a distance away from the center of the screen resulting in large offsets and thus a large movement jump. We can circumvent this issue by simply defining a global `bool` variable to check if this is the first time we receive mouse input and if so, we first update the initial mouse positions to the new `xpos` and `ypos` values; the resulting mouse movements will then use the entered mouse's position coordinates to calculate its offsets:

```

if(firstMouse) // this bool variable is initially set to true
{
    lastX = xpos;
    lastY = ypos;
    firstMouse = false;
}

```

The final code then becomes:

```

void mouse_callback(GLFWwindow* window, double xpos, double ypos)
{
    if(firstMouse)
    {
        lastX = xpos;
        lastY = ypos;
        firstMouse = false;
    }

    GLfloat xoffset = xpos - lastX;
    GLfloat yoffset = lastY - ypos;
    lastX = xpos;
    lastY = ypos;

    GLfloat sensitivity = 0.05;
    xoffset *= sensitivity;
    yoffset *= sensitivity;

    yaw += xoffset;
    pitch += yoffset;

    if(pitch > 89.0f)
        pitch = 89.0f;
    if(pitch < -89.0f)
        pitch = -89.0f;

    glm::vec3 front;
    front.x = cos(glm::radians(yaw)) * cos(glm::radians(pitch));
    front.y = sin(glm::radians(pitch));
    front.z = sin(glm::radians(yaw)) * cos(glm::radians(pitch));
    cameraFront = glm::normalize(front);
}

```

There we go! Give it a spin and you'll see that we can now freely move through our 3D scene! If you're still stuck somewhere, check the [source code](#).

10.8 Zoom

As a little extra to the camera system we'll also implement a zooming interface. In the previous tutorial we said the *Field of view* or *fov* defines how much we can see of the scene. When the field of view becomes smaller the scene's projected space gets smaller giving the illusion of zooming in. To zoom in, we're going to use the mouse's scroll-wheel. Similar to mouse movement and keyboard input we have a callback function for mouse-scrolling:

```

void scroll_callback(GLFWwindow* window, double xoffset, double yoffset)
{

```

```
if(fov >= 1.0f && fov <= 45.0f)
    fov -= yoffset;
if(fov <= 1.0f)
    fov = 1.0f;
if(fov >= 45.0f)
    fov = 45.0f;
}
```

When scrolling, the `yoffset` value represents the amount we scrolled vertically. When the `scroll_callback` function is called we change the content of the globally declared `fov` variable. Since `45.0f` is the default fov value we want to constrain the zoom level between `1.0f` and `45.0f`.

We now have to upload the perspective projection matrix to the GPU each render iteration but this time with the `fov` variable as its field of view:

```
projection = glm::perspective(fov, (GLfloat)WIDTH/(GLfloat)HEIGHT, 0.1f,
    100.0f);
```

And lastly don't forget to register the scroll callback function:

```
glfwSetScrollCallback(window, scroll_callback);
```

And there you have it. We implemented a simple camera system that allows for free movement in a 3D environment.

See video online

Feel free to experiment a little and if you're stuck compare your code with the [source code](#).

Note that a camera system using Euler angles is still not a perfect system. Depending on your constraints and your setup you could still introduce a [Gimbal lock](#). The best camera system would be developed using *quaternions* but we'll leave that to a later topic.

10.9 Camera class

In the upcoming tutorials we will always use a camera to easily look around the scenes and see the results from all angles. However, since a camera can take up quite some space on each tutorial we'll abstract a little from the details and create our own camera object that does most of the work for us with some neat little extras. Unlike the Shader tutorial we won't walk you through creating the camera class, but just provide you with the (fully commented) source code if you want to know the inner workings.

Just like the Shader object we create it entirely in a single header file. You can find the camera object [here](#). You should be able to understand all the code by now. It is advised to at least check the class out once to see how you could create a camera object like this.

The camera system we introduced is an FPS-like camera that suits most purposes and works well with Euler angles, but be careful when creating different camera systems like a flight simulation camera. Each camera system has its own tricks and quirks so be sure to read up on them. For example, this FPS camera doesn't allow for pitch values higher than 90 degrees and a static up vector of $(0, 1, 0)$ doesn't work when we take roll values into account.

The updated version of the source code using the new camera object can be found [here](#).

10.10 Exercises

- See if you can transform the camera class in such a way that it becomes a **true** fps camera where you cannot fly; you can only look around while staying on the xz plane: [solution](#).
- Try to create your own LookAt function where you manually create a view matrix as discussed at the start of this tutorial. Replace glm's LookAt function with your own implementation and see if it still acts the same: [solution](#).

A futuristic cityscape with a flying vehicle in the foreground. The vehicle is dark with blue lights and is flying towards the left. The city is filled with tall, thin buildings and is shrouded in a light mist or fog. The sky is a pale blue.

11. Review

Congratulations on reaching the end of the *Getting started* section. By now you should be able to create a window, create and compile shaders, send vertex data to your shaders via buffer objects or uniforms, draw objects, use textures, understand vectors and matrices and combine all that knowledge to create a full 3D scene with a camera to play around with.

Phew, that is a lot that we learned these last few chapters. Try to play around with the tutorials, experiment a bit or come up with your own ideas and solutions to some of the problems. As soon as you feel you got the hang of all the materials we've discussed it's time to move on to the [next](#) tutorials.

11.1 Glossary

- **OpenGL:** a formal specification of a graphics API that defines the layout and output of each function.
- **GLEW:** an extension loading library that loads and sets all OpenGL's function pointers for us so we can use all (modern) OpenGL's functions.
- **Viewport:** the window where we render to.
- **Graphics Pipeline:** the entire process a vertex has to walk through before ending up as a pixel on your screen.
- **Shader:** a small program that runs on the graphics card. Several stages of the graphics pipeline can use user-made shaders to replace existing functionality.
- **Vertex:** a collection of data that represent a single point.
- **Normalized Device Coordinates:** the coordinate system your vertices end up in after clipping and perspective division is performed on clip coordinates. All vertex positions in NDC between -1.0 and 1.0 will not be discarded and end up visible.
- **Vertex Buffer Object:** a buffer object that allocates memory and stores all the vertex data for the graphics card to use.
- **Vertex Array Object:** stores buffer and vertex attribute state information.

- `Element Buffer Object`: a buffer object that stores indices for indexed drawing.
- `Uniform`: a special type of GLSL variable that is global (each shader in a shader program can access this uniform variable) and only has to be set once.
- `Texture`: a special type of image wrapped around objects, giving the illusion an object is extremely detailed.
- `Texture Wrapping`: defines the mode that specifies how OpenGL should sample textures when texture coordinates are outside the range: (0, 1).
- `Texture Filtering`: defines the mode that specifies how OpenGL should sample the texture when there are several texels (texture pixels) to choose from. This usually occurs when a texture is magnified.
- `Mipmaps`: stored smaller versions of a texture where the appropriate sized version is chosen based on the distance to the viewer.
- `SOIL`: image loading library.
- `Texture Units`: allows for multiple textures on a single object by binding multiple textures each to a different texture unit.
- `Vector`: a mathematical entity that defines directions and/or positions in any dimension.
- `Matrix`: a rectangular array of mathematical expressions.
- `GLM`: a mathematics library tailored for OpenGL.
- `Local Space`: the space an object begins in. All coordinates relative to an object's origin.
- `World Space`: all coordinates relative to a global origin.
- `View Space`: all coordinates as viewed from a camera's perspective.
- `Clip Space`: all coordinates as viewed from the camera's perspective but with projection applied. This is the space the vertex coordinates should end up in, as output of the vertex shader. OpenGL does the rest (clipping/perspective division).
- `Screen Space`: all coordinates as viewed from the screen. Coordinates range from 0 to screen width/height.
- `LookAt`: a special type of view matrix that creates a coordinate system where all coordinates are rotated and translated in such a way that the user is looking at a given target from a given position.
- `Euler Angles`: defined as `yaw`, `pitch` and `roll` that allow us to form any 3D direction vector from these 3 values.

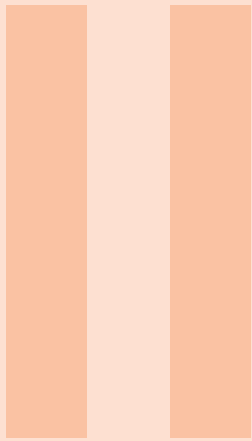

Lighting

12	Colors	127
13	Basic Lighting	133
14	Materials	146
15	Lighting maps	154
16	Light casters	161
17	Multiple lights	175
18	Review	182

A futuristic cityscape with a flying vehicle in the foreground. The vehicle is dark with blue glowing lights and is flying towards the left. The city in the background is filled with tall, thin buildings and is slightly hazy.

12. Colors

We briefly mentioned how to work with colors in OpenGL in the previous tutorials, but so far only touched the surface of colors. Here we'll extensively discuss what colors are and start building the scene for the upcoming lighting tutorials.

In the real world, colors can take practically any known color value with each object having its own color(s). In the digital world we need to map the (infinite) real colors to (limited) digital values and therefore not all real-world colors can be represented digitally. We can however represent so many colors that you probably won't notice the difference anyways. Colors are digitally represented using a red, green and blue component commonly abbreviated as RGB. Using different combinations of just those 3 values we can represent almost any color there is. For example, to get a *coral* color we define a color vector as:

```
glm::vec3 coral(1.0f, 0.5f, 0.31f);
```

The colors we see in real life are not the colors the objects actually have, but are the colors **reflected** from the object; the colors that are not absorbed (rejected) by the objects are the colors we perceive of them. For example, the light of the sun is perceived as a white light that is the combined sum of many different colors (as you can see in the image). So if we would shine the white light on a blue toy, it absorbs all the white color's sub-colors except the blue color. Since the toy does not absorb the blue value, it is reflected and this reflected light enters our eye, making it look like the toy has a blue color. The following image shows this for a coral colored toy where it reflects several colors with varying intensity:

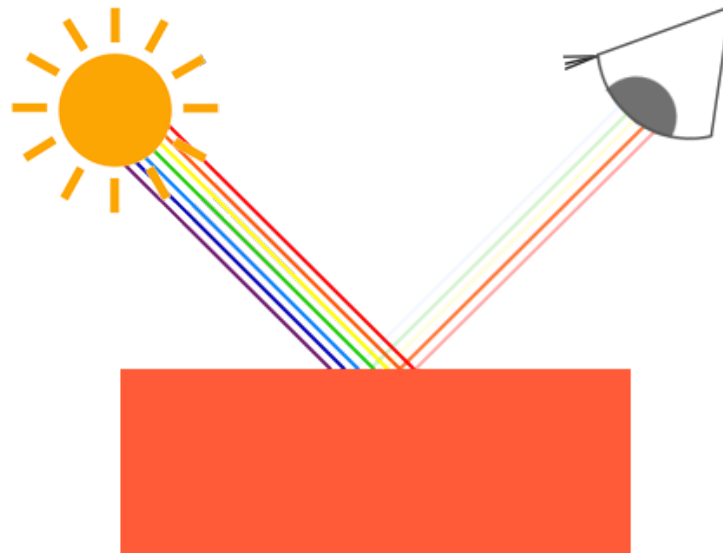

You can see that the white sunlight is actually a collection of all the visible colors and the object absorbs a large portion of those colors. It only reflects those colors that represent the object's color and the combination of those is what we perceive (in this case a coral color).

These rules of color reflection apply directly in graphics-land. When we define a light source in OpenGL we want to give this light source a color. In the previous paragraph we had a white color so we'll give the light source a white color as well. If we would then multiply the light source's color with an object's color value, the resulting color is the reflected color of the object (and thus its perceived color). Let's revisit our toy (this time with a coral value) and see how we would calculate its perceivable color in graphics-land. We retrieve the resulting color vector by doing a component-wise multiplication on both color vectors:

```
glm::vec3 lightColor(1.0f, 1.0f, 1.0f);
glm::vec3 toyColor(1.0f, 0.5f, 0.31f);
glm::vec3 result = lightColor * toyColor; // = (1.0f, 0.5f, 0.31f);
```

We can see that the toy's color *absorbs* a large portion of the white light, but reflects several red, green and blue values based on its own color value. This is a representation of how colors would work in real life. We can thus define an object's color as *the amount of each color component it reflects from a light source*. Now what would happen if we used a green light?

```
glm::vec3 lightColor(0.0f, 1.0f, 0.0f);
glm::vec3 toyColor(1.0f, 0.5f, 0.31f);
glm::vec3 result = lightColor * toyColor; // = (0.0f, 0.5f, 0.0f);
```

As we can see, the toy has no red and blue light to absorb and/or reflect. The toy also absorbs half of the light's green value, but also still reflects half of the light's green value. The toy's color we perceive would then be a dark-greenish color. We can see that if we use a green light, only the green color components can be reflected and thus perceived; no red and blue colors are perceived. The result is that the coral object suddenly becomes a dark-greenish object. Let's try one more example with a dark olive-green light:

```
glm::vec3 lightColor(0.33f, 0.42f, 0.18f);
glm::vec3 toyColor(1.0f, 0.5f, 0.31f);
```

```
glm::vec3 result = lightColor * toyColor; // = (0.33f, 0.21f, 0.06f);
```

As you can see, we can get unexpected colors from objects by using different light colors. It's not hard to get creative with colors.

But enough about colors, let's start building a scene where we can experiment in.

12.1 A lighting scene

In the upcoming tutorials we'll be creating interesting visuals by simulating real-world lighting making extensive use of colors. Since now we'll be using light sources we want to display them as visual objects in the scene and add at least one object to simulate the lighting on.

The first thing we need is an object to cast the light on and we'll use the infamous container cube from the previous tutorials. We will also be needing a light object to show where the light source is located in the 3D scene. For simplicity's sake we'll represent the light source with a cube as well (we already have the [vertex data](#) right?).

So, filling a vertex buffer object, setting vertex attribute pointers and all that weird stuff should be easy for you by now so we won't walk you through those steps. If you still have difficulties with those items I suggest you review the [previous tutorials](#) and work through the exercises if possible before continuing.

So, the first thing we will actually need is a vertex shader to draw the container. The vertex positions of the container remain the same (although we won't be needing texture coordinates this time) so the code should be nothing new. We'll be using a stripped down version of the vertex shader from the last tutorials:

```
#version 330 core
layout (location = 0) in vec3 position;

uniform mat4 model;
uniform mat4 view;
uniform mat4 projection;

void main()
{
    gl_Position = projection * view * model * vec4(position, 1.0f);
}
```

Make sure to update your vertex data and attribute pointers to correspond with the new vertex shader (if you want you can actually keep the texture data and attribute pointers active; we're just not using them right now, but it's not a bad idea to start from a fresh start).

Because we are also going to create a lamp cube, we want to generate a new VAO specifically for the lamp. We could also represent a lamp using the same VAO and then simply do some transformations on the `model` matrix, but in the upcoming tutorials we'll be changing the vertex data and attribute pointers of the container object quite often and we don't want these changes to propagate to the lamp object (we only care about the lamp's vertex positions), so we'll create a new VAO:

```

GLuint lightVAO;
glGenVertexArrays(1, &lightVAO);
glBindVertexArray(lightVAO);
// We only need to bind to the VBO, the container's VBO's data already
// contains the correct data.
glBindBuffer(GL_ARRAY_BUFFER, VBO);
// Set the vertex attributes (only position data for our lamp)
glVertexAttribPointer(0, 3, GL_FLOAT, GL_FALSE, 3 * sizeof(GLfloat), (
    GLvoid*)0);
glEnableVertexAttribArray(0);
glBindVertexArray(0);

```

The code should be relatively straightforward. Now that we created both the container and the lamp cube there is one thing left to define and that is the fragment shader:

```

#version 330 core
out vec4 color;

uniform vec3 objectColor;
uniform vec3 lightColor;

void main()
{
    color = vec4(lightColor * objectColor, 1.0f);
}

```

The fragment shader accepts both an object color and a light color from a uniform variable. Here we multiply the light's color with the object's (reflected) color just like we discussed at the beginning of this tutorial. Again, this shader should be easy to understand. Let's set the object's color to the last section's coral color with a white light:

```

// Don't forget to 'use' the corresponding shader program first (to set the
// uniform)
GLuint objectColorLoc = glGetUniformLocation(lightningShader.Program, "
    objectColor");
GLuint lightColorLoc = glGetUniformLocation(lightningShader.Program, "
    lightColor");
glUniform3f(objectColorLoc, 1.0f, 0.5f, 0.31f);
glUniform3f(lightColorLoc, 1.0f, 1.0f, 1.0f); // Also set light's color (
    white)

```

One thing left to note is that when we start to change the vertex and fragment shaders, the lamp cube will change as well and this is not what we want. We don't want the lamp object's color to be affected by the lighting calculations in the upcoming tutorials, but rather keep the lamp isolated from the rest. We want the lamp to have a constant bright color, unaffected by other color changes (this makes it look like the lamp really is the source of the light).

To accomplish this we actually need to create a second set of shaders that we will use to draw the lamp, thus being safe from any changes to the lighting shaders. The vertex shader is the same as the current vertex shader so you can simply copy the source code for the lamp's vertex shader. The fragment shader of the lamp ensures the lamp's color stays bright by defining a constant white color on the lamp:

```

#version 330 core

```



```
out vec4 color;

void main()
{
    color = vec4(1.0f); // Set alle 4 vector values to 1.0f
}
```

When we want to draw our objects, we want to draw the container object (or possibly many other objects) using the lighting shader we just defined and when we want to draw the lamp, we use the lamp's shaders. During the tutorials we'll gradually be updating the lighting shaders to slowly achieve more realistic results.

The main purpose of the lamp cube is to show where the light comes from. We usually define a light source's position somewhere in the scene, but this is simply a position that has no visual meaning. To show the actual lamp we draw the lamp cube at the same location of the light source. This is accomplished by drawing the lamp object with the lamp shader, ensuring the lamp cube always stays white, regardless of the light conditions of the scene.

So let's declare a global `vec3` variable that represents the light source's location in world-space coordinates:

```
glm::vec3 lightPos(1.2f, 1.0f, 2.0f);
```

We then want to translate the lamp's cube to the light source's position before drawing it and we'll also scale it down a bit to make sure the lamp isn't too dominant:

```
model = glm::mat4();
model = glm::translate(model, lightPos);
model = glm::scale(model, glm::vec3(0.2f));
```

The resulting drawing code for the lamp should then look something like this:

```
lampShader.Use();
// Set the model, view and projection matrix uniforms
...
// Draw the lamp object
glBindVertexArray(lightVAO);
glDrawArrays(GL_TRIANGLES, 0, 36);
glBindVertexArray(0);
```

Injecting all the code fragments at their appropriate locations would then result in a clean OpenGL application properly configured for experimenting with lighting. If everything compiles it should look like this:

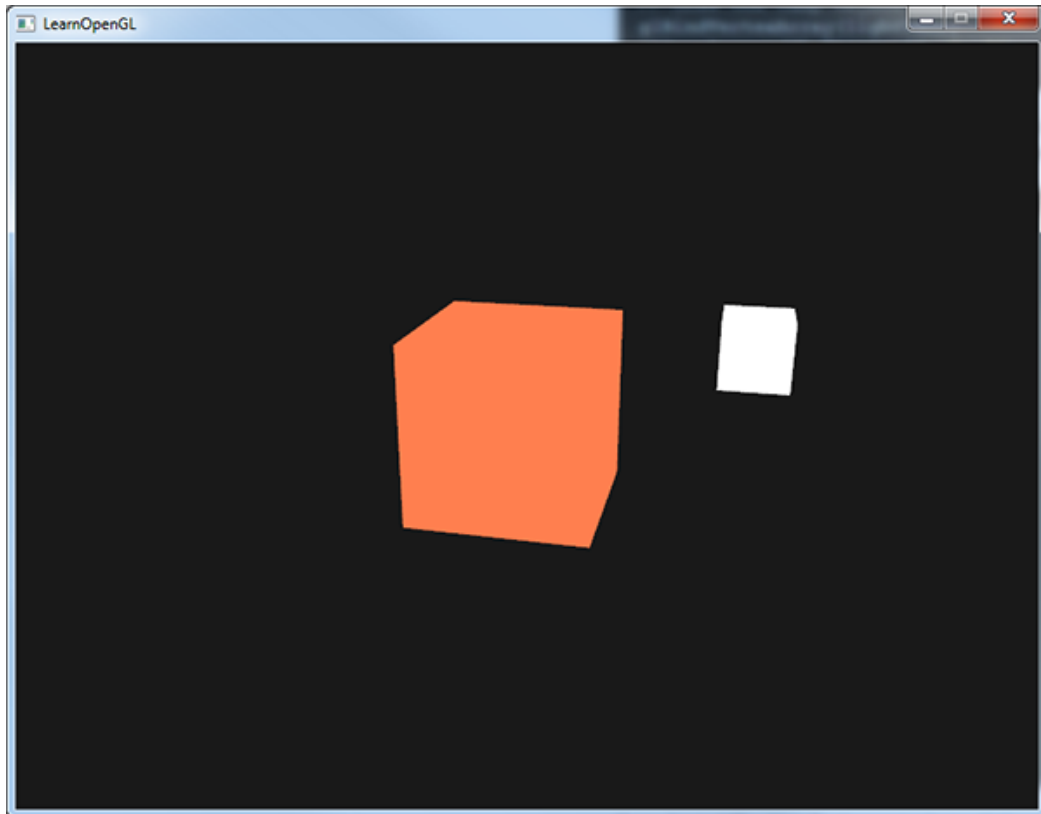

Not really much to look at right now, but I'll promise it will get more interesting in the upcoming tutorials.

If you have difficulties finding out where all the code snippets fit together in the application as a whole, check the [source code](#) and carefully work your way through the code/comments.

Now that we have a fair bit of knowledge about colors and created a basic scene for some sexy lighting stuff we can jump to the [next](#) tutorial where the real magic begins.

13. Basic Lighting

Lighting in the real world is extremely complicated and depends on way too many factors, something we can't afford to calculate on the limited processing power we have. Lighting in OpenGL is therefore based on approximations of reality using simplified models that are much easier to process and look relatively similar. These lighting models are based on the physics of light as we understand it. One of those models is called the **Phong lighting model**. The major building blocks of the Phong model consist of 3 components: ambient, diffuse and specular lighting. Below you can see what these lighting components actually look like:

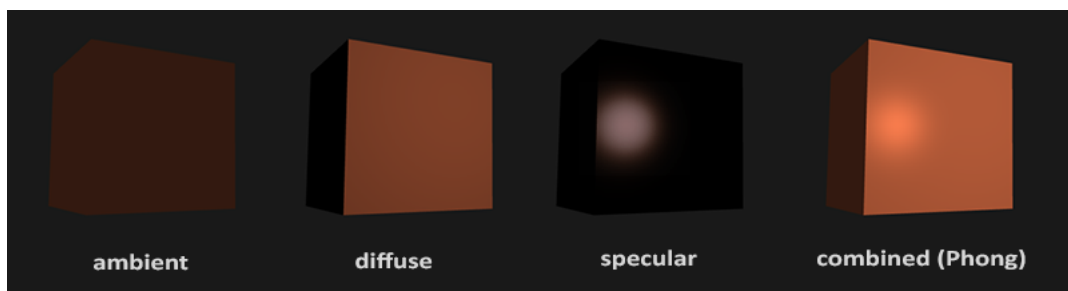

- **Ambient lighting:** even when it is dark there is usually still some light somewhere in the world (the moon, a distant light) so objects are almost never completely dark. To simulate this we use an ambient lighting constant that always gives the object some color.
- **Diffuse lighting:** simulates the directional impact a light object has on an object. This is the most visually significant component of the lighting model. The more a part of an object faces the light source, the brighter it becomes.
- **Specular lighting:** simulates the bright spot of a light that appears on shiny objects. Specular highlights are often more inclined to the color of the light than the color of the object.

To create visually interesting scenes we want to at least simulate these 3 lighting components. We'll start with the simplest one: *ambient lighting*.

13.1 Ambient lighting

Light usually does not come from a single light source, but from many light sources scattered all around us, even when they're not immediately visible. One of the properties of light is that it can scatter and bounce in many directions reaching spots that aren't in its direct vicinity; light can thus *reflect* on other surfaces and have an indirect impact on the lighting of an object. Algorithms that take this into consideration are called **global illumination** algorithms, but these are expensive and/or complicated.

Since we're not big fans of complicated and expensive algorithms we'll start by using a very simplistic model of global illumination, namely **ambient lighting**. As you've seen in the previous section we use a small constant (light) color that we add to the final resulting color of the object's fragments, thus making it look like there is always some scattered light even when there's not a direct light source.

Adding ambient lighting to the scene is really easy. We take the light's color, multiply it with a small constant ambient factor, multiply this with the object's color and use it as the fragment's color:

```
void main()
{
    float ambientStrength = 0.1f;
    vec3 ambient = ambientStrength * lightColor;

    vec3 result = ambient * objectColor;
    color = vec4(result, 1.0f);
}
```

If you'd now run your program, you'll notice that the first stage of lighting is now successfully applied to your object. The object is quite dark, but not completely since ambient lighting is applied (note that the light cube is unaffected because we use a different shader). It should look something like this:

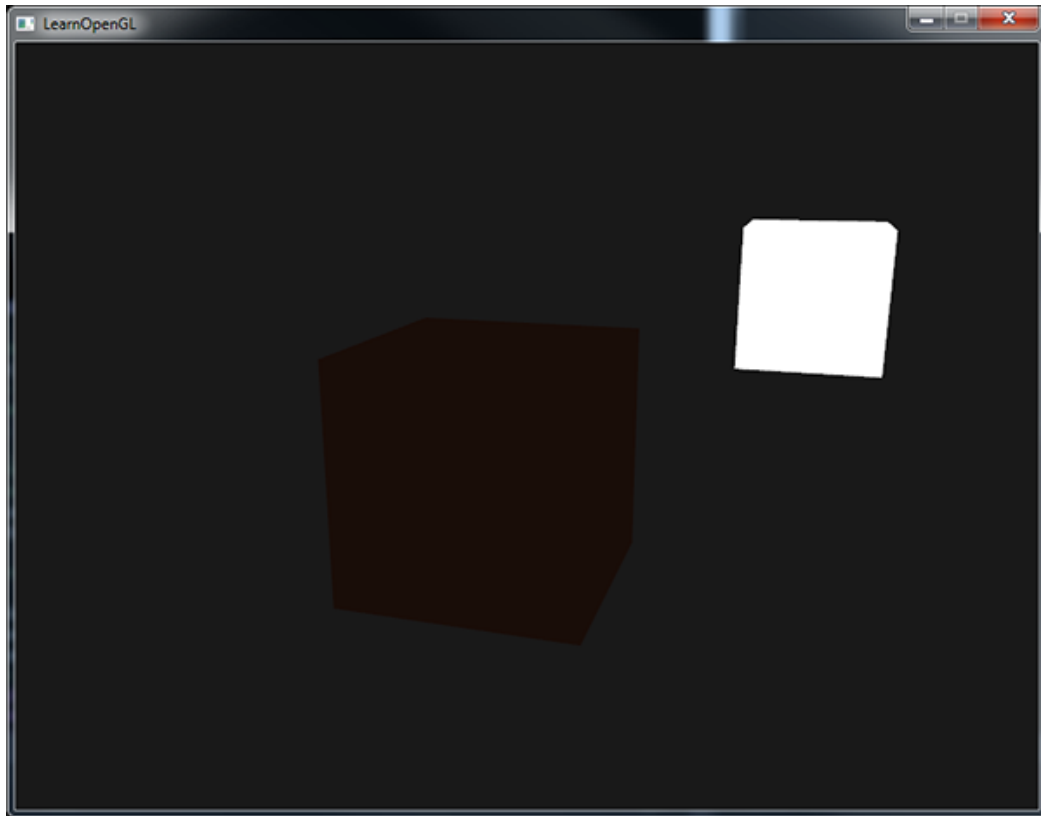

13.2 Diffuse lighting

Ambient lighting by itself does not produce the most interesting results, but diffuse lighting will start to give a significant visual impact on the object. Diffuse lighting gives the object more brightness the closer its fragments are aligned to the light rays from a light source. To give you a better understanding of diffuse lighting take a look at the following image:

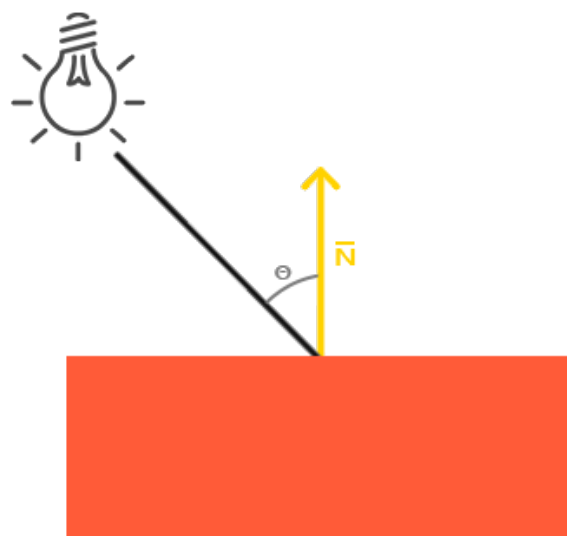

To the left we find a light source with a light ray targeted at a single fragment of our object. We then need to measure at what angle the light ray touches the fragment. If the light ray is perpendicular to the object's surface the light has the greatest impact. To measure the angle between

the light ray and the fragment we use something called a **normal vector** that is a vector perpendicular to the fragment's surface (here depicted as a yellow arrow); we'll get to that later. The angle between the two vectors can then easily be calculated with the dot product.

You might remember from the [transformations](#) tutorial that the lower the angle between two unit vectors, the more the dot product is inclined towards a value of 1. When the angle between both vectors is 90 degrees, the dot product becomes 0. The same applies to θ : the larger θ becomes, the less of an impact the light should have on the fragment's color.

Note that to get (only) the cosine of the angle between both vectors we will work with *unit vectors* (vectors of length 1) so we need to make sure all the vectors are normalized, otherwise the dot product returns more than just the cosine (see [Transformations](#)).

The resulting dot product thus returns a scalar that we can use to calculate the light's impact on the fragment's color, resulting in differently lit fragments, based on their orientation towards the light.

So, what do we need to calculate diffuse lighting?

- Normal vector: a vector that is perpendicular to the vertex' surface.
- The directed light ray: a direction vector that is the difference vector between the light's position and the fragment's position. To calculate this light ray we need the light's position vector and the fragment's position vector.

13.3 Normal vectors

A normal vector is a (unit) vector that is perpendicular to the surface of a vertex. Since a vertex by itself has no surface (it's just a single point in space) we retrieve a normal vector by using its surrounding vertices to figure out the surface of the vertex. We can use a little trick to calculate the normal vectors for all the cube's vertices by using the cross product, but since a 3D cube is not a complicated shape we can simply manually add them to the vertex data. The updated vertex data array can be found [here](#). Try to visualize that the normals are indeed vectors perpendicular to the plane's surfaces of the cube (a cube consists of 6 planes).

Since we added extra data to the vertex array we should update the lighting's vertex shader:

```
#version 330 core
layout (location = 0) in vec3 position;
layout (location = 1) in vec3 normal;
...
```

Now that we added a normal vector to each of the vertices and updated the vertex shader we should update the vertex attribute pointers as well. Note that the lamp object uses the same vertex array for its vertex data, but the lamp shader has no use of the newly added normal vectors. We don't have to update the lamp's shaders or attribute configurations, but we have to at least modify the vertex attribute pointers to reflect the new vertex array's size:

```
glVertexAttribPointer(0, 3, GL_FLOAT, GL_FALSE, 6 * sizeof(GLfloat), (
    GLvoid*)0);
```

```
glEnableVertexAttribArray(0);
```

We only want to use the first 3 floats of each vertex and ignore the last 3 floats so we only need to update the *stride* parameter to 6 times the size of a `GLfloat` and we're done.

It may look inefficient using vertex data that is not completely used by the lamp shader, but the vertex data is already stored in the GPU's memory from the container object so we don't have to store new data into the GPU's memory. This actually makes it more efficient compared to allocating a new VBO specifically for the lamp.

All the lighting calculations are done in the fragment shader so we need to forward the normal vectors from the vertex shader to the fragment shader. Let's do that:

```
out vec3 Normal;

void main()
{
    gl_Position = projection * view * model * vec4(position, 1.0f);
    Normal = normal;
}
```

What's left to do is declare the corresponding input variable in the fragment shader:

```
in vec3 Normal;
```

13.4 Calculating the diffuse color

We now have the normal vector for each vertex, but we still need the light's position vector and the fragment's position vector. Since the light's position is just a single static variable we can simply declare it as a uniform in the fragment shader:

```
uniform vec3 lightPos;
```

And then update the uniform in the game loop (or outside since it doesn't change). We use the `lightPos` vector declared in the previous tutorial as the location of the light source:

```
GLint lightPosLoc = glGetUniformLocation(lightningShader.Program, "lightPos");
glUniform3f(lightPosLoc, lightPos.x, lightPos.y, lightPos.z);
```

Then the last thing we need is the actual fragment's position. We're going to do all the lighting calculations in world space so we want a vertex position that is in world space. We can accomplish this by multiplying the vertex position attribute with the model matrix only (not the view and projection matrix) to transform it to world space coordinates. This can easily be accomplished in the vertex shader so let's declare an output variable and calculate its world space coordinates:

```
out vec3 FragPos;
out vec3 Normal;

void main()
```

```
{
    gl_Position = projection * view * model * vec4(position, 1.0f);
    FragPos = vec3(model * vec4(position, 1.0f));
    Normal = normal;
}
```

And lastly add the corresponding input variable to the fragment shader:

```
in vec3 FragPos;
```

Now that all the required variables are set we can start with the lighting calculations in the fragment shader.

The first thing we need to calculate is the direction vector between the light source and the fragment's position. We mentioned that the light's direction vector is the difference vector between the light's position vector and the fragment's position vector. As you might remember from the [transformations](#) tutorial we can easily calculate this difference by subtracting both vectors. We also want to make sure all the relevant vectors end up as unit vectors so we normalize both the normal and the resulting direction vector:

```
vec3 norm = normalize(Normal);
vec3 lightDir = normalize(lightPos - FragPos);
```

When calculating lighting we usually do not care about the magnitude of a vector or their position; we only care about their direction. Because we only care about their direction almost all the calculations are done with unit vectors since it simplifies most calculations (like the dot product). So when doing lighting calculations, make sure you always normalize the relevant vectors to ensure they're actual unit vectors. Forgetting to normalize a vector is a popular mistake.

Next we want to calculate the actual diffuse impact the light has on the current fragment by taking the dot product of the `norm` and `lightDir` vector. The resulting value is then multiplied with the light's color to get the diffuse component, resulting in a darker diffuse component the greater the angle is between both vectors:

```
float diff = max(dot(norm, lightDir), 0.0);
vec3 diffuse = diff * lightColor;
```

If the angle between both vectors is greater than 90 degrees then the result of the dot product will actually become negative and we end up with a negative diffuse component. For that reason we use the `max` function that returns the highest of both its parameters to make sure the diffuse component (and thus the colors) never become negative. Lighting for negative colors is not really defined so it's best to stay away from that, unless you're one of those eccentric artists.

Now that we have both an ambient and a diffuse component we add both colors to each other and then multiply the result with the color of the object to get the resulting fragment's output color:

```
vec3 result = (ambient + diffuse) * objectColor;
color = vec4(result, 1.0f);
```

If your application (and shaders) compiled successfully you should see something like this:

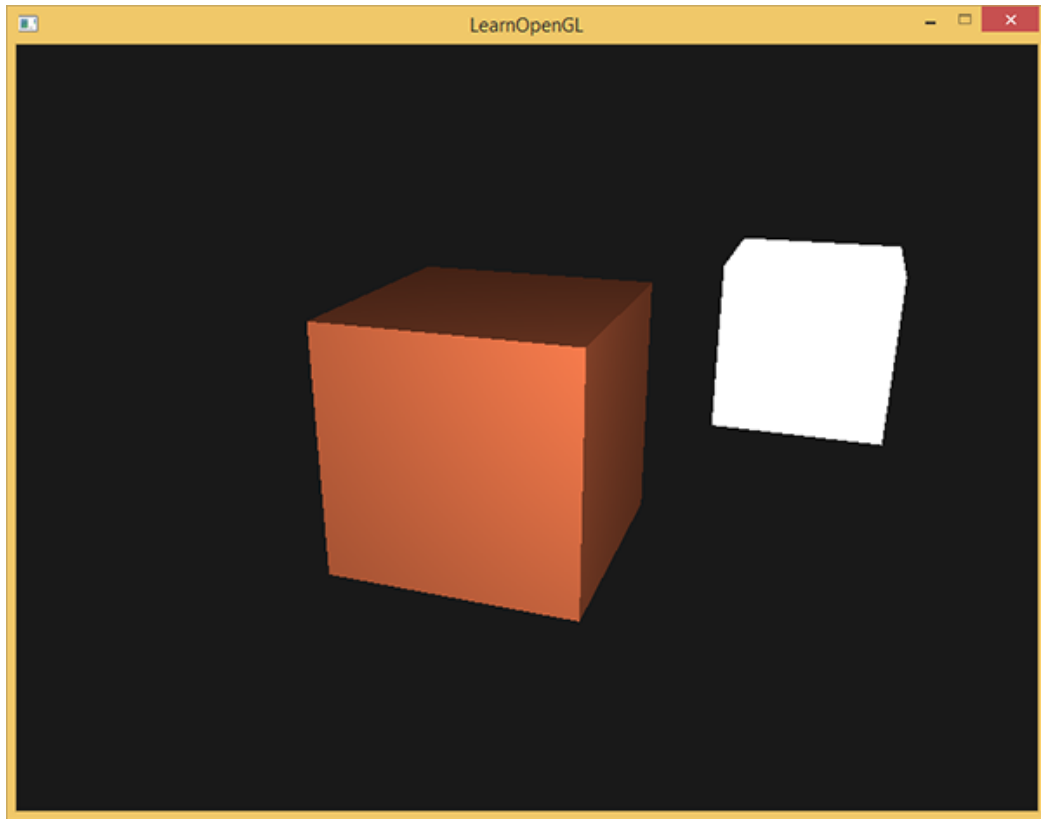

You can see that with diffuse lighting the cube starts to look like an actual cube again. Try visualizing the normal vectors in your head and move around the cube to see that the larger the angle between them and the light's direction, the darker a fragment becomes.

Feel free to compare your source code with the complete source code [here](#) and the fragment shader's code [here](#) if you're stuck.

13.5 One last thing

As of now we've been passing the normal vectors directly from the vertex shader to the fragment shader. However, the calculations we've been doing in the fragment shader are all done in world space coordinates, so shouldn't we transform the normal vectors to world space coordinates as well? Basically yes, but it's not as simple as simply multiplying it with a model matrix.

First of all, normal vectors are only direction vectors and do not represent a specific position in space. Also, normal vectors do not have a homogeneous coordinate (the w component of a vertex position). This means that translations do and should not have any effect on the normal vectors. So if we want to multiply the normal vectors with a model matrix we want to remove the translation part of the matrix by taking the upper-left 3×3 matrix of the model matrix (note that we could also set the w component of a normal vector to 0 and multiply with the 4×4 matrix; this removes translation as well). The only transformations we want to apply to normal vectors are scale and rotation transformations.

Second, if the model matrix would perform a non-uniform scale, the vertices would be changed in such a way that the normal vector is not perpendicular to the surface anymore, so we can't transform the normal vectors with such a model matrix. The following image shows the effect such a model matrix (with non-uniform scaling) has on a normal vector:

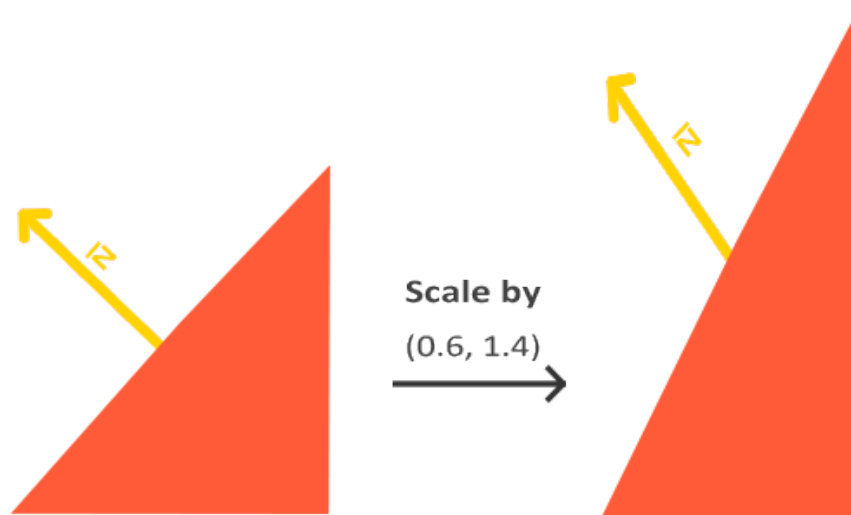

Whenever we apply a non-uniform scale (note: uniform scales won't hurt the normals since their directions do not change, just their magnitude which is easily fixed by normalizing them) the normal vectors are not perpendicular to the corresponding surface anymore which distorts the lighting.

The trick of fixing this behavior is to use a different model matrix specifically tailored for normal vectors. This matrix is called the **normal matrix** and uses a few linear algebraic operations to remove the effect of wrongly scaling the normal vectors. If you want to know how this matrix is actually calculated I suggest the following [article](#).

The normal matrix is defined as 'the transpose of the inverse of the upper-left corner of the model matrix'. Phew, that's a mouthful and if you don't really understand what that means, don't worry; we haven't discussed inverse and transpose matrices yet. Note that most resources define the normal matrix as these operations applied to the model-view matrix, but since we're working in world space (and not in view space) we only use the model matrix.

In the vertex shader we can generate this normal matrix ourselves by using the `inverse` and `transpose` functions in the vertex shader that work on any matrix type. Note that we also cast the matrix to a 3x3 matrix to ensure it loses its translation properties and that it can multiply with the `vec3` normal vector:

```
Normal = mat3(transpose(inverse(model))) * normal;
```

In the diffuse lighting section the lighting was just fine because we did not perform any scaling operation on the object itself so there was not really a need to use a normal matrix and could've just multiplied the normals with the model matrix. If you are doing a non-uniform scale however, it is essential that you multiply your normal vector with the normal matrix.

Inverting matrices is a costly operation even for shaders so wherever possible, try to avoid doing inverse operations in shaders since they have to be done on each vertex of your scene. For learning purposes this is fine, but for an efficient application you'll likely want to calculate the normal matrix on the CPU and send it to the shaders via a uniform before drawing (just like the model matrix).

13.6 Specular Lighting

If you're not already exhausted by all the lighting calculations we can start finishing the Phong lighting model by adding specular highlights.

Just like diffuse lighting, specular lighting is based on the light's direction vector and the object's normal vectors, but this time it is also based on the view direction e.g. from what direction the player is looking at the fragment. Specular lighting is based on the reflective properties of light. If we think of the object's surface as a mirror, the specular lighting is the strongest wherever we would see the light reflected on the surface. You can see this effect in the following image:

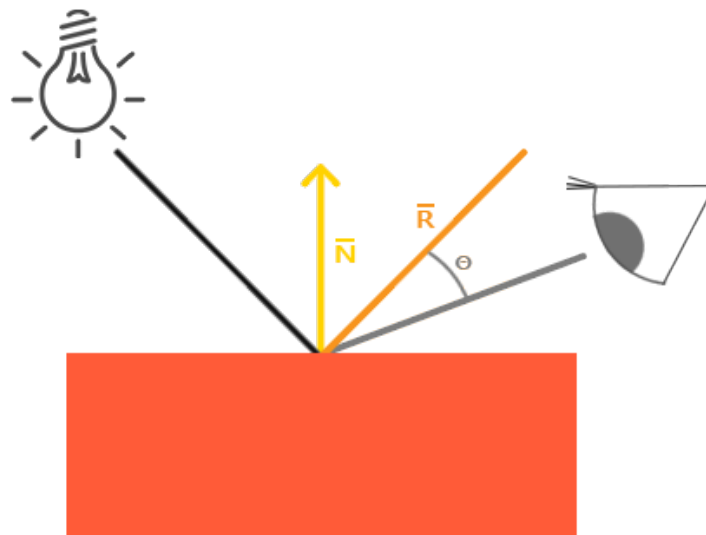

We calculate a reflection vector by reflecting the light direction around the normal vector. Then we calculate the angular distance between this reflection vector and the view direction and the closer the angle between them, the greater the impact of the specular light. The resulting effect is that we see a bit of a highlight when we're looking at the light's direction reflected via the object.

The view vector is the one extra variable we need for specular lighting which we can calculate using the viewer's world space position and the fragment's position. Then we calculate the specular's intensity, multiply this with the light color and add this to the resulting ambient and diffuse components.

We chose to do the lighting calculations in world space, but most people tend to prefer doing lighting in view space. The added advantage of calculating in view space is that the viewer's position is always at $(0, 0, 0)$ so you already got the position of the viewer for free. However, I find calculating lighting in world space more intuitive for learning purposes. If you still want to calculate lighting in view space you want to transform all the relevant vectors with the view matrix as well (don't forget to change the normal matrix too).

To get the world space coordinates of the viewer we simply take the position vector of the camera object (which is the viewer of course). So let's add another uniform to the fragment shader and pass the corresponding camera position vector to the fragment shader:

```
uniform vec3 viewPos;
```

```
GLint viewPosLoc = glGetUniformLocation(lightningShader.Program, "viewPos");  
glUniform3f(viewPosLoc, camera.Position.x, camera.Position.y, camera.  
    Position.z);
```

Now that we have all the required variables we can calculate the specular intensity. First we define a specular intensity value to give the specular highlight a medium-bright color so that it doesn't have too much of an impact:

```
float specularStrength = 0.5f;
```

If we would set this to `1.0f` we'd get a really bright specular component which is a bit too much for a coral cube. In the [next](#) tutorial we'll talk about properly setting all these lighting intensities and how they affect the objects. Next we calculate the view direction vector and the corresponding reflect vector along the normal axis:

```
vec3 viewDir = normalize(viewPos - FragPos);  
vec3 reflectDir = reflect(-lightDir, norm);
```

Note that we negate the `lightDir` vector. The `reflect` function expects the first vector to point **from** the light source towards the fragment's position, but the `lightDir` vector is currently pointing the other way around from the fragment **towards** the light source (depends on the order of subtraction earlier on when we calculated the `lightDir` vector). To make sure we get the correct reflect vector we reverse its direction by negating the `lightDir` vector first. The second argument expects a normal vector so we supply the normalized `norm` vector.

Then what's left to do is to actually calculate the specular component. This is accomplished with the following formula:

```
float spec = pow(max(dot(viewDir, reflectDir), 0.0), 32);  
vec3 specular = specularStrength * spec * lightColor;
```

We first calculate the dot product between the view direction and the reflect direction (and make sure it's not negative) and then raise it to the power of 32. This 32 value is the `shininess` value of the highlight. The higher the shininess value of an object, the more it properly reflects the light instead of scattering it all around and thus the smaller the highlight becomes. Below you can see an image that shows the visual impact of different shininess values:

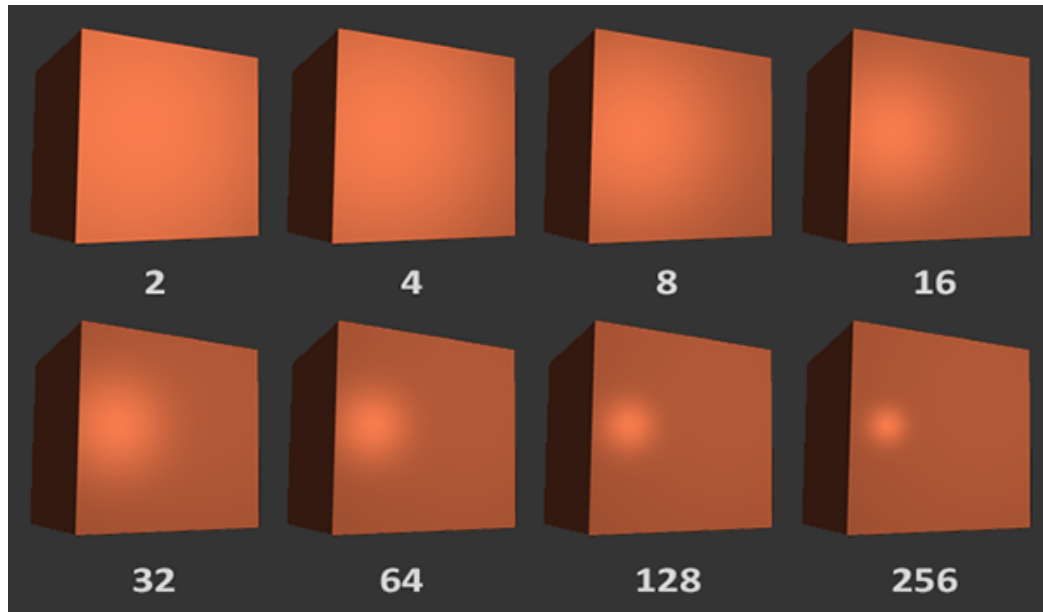

We don't want the specular component to be too dominant so we keep the exponent at 32. The only thing left to do is to add it to the ambient and diffuse components and multiply the combined result with the object's color:

```
vec3 result = (ambient + diffuse + specular) * objectColor;  
color = vec4(result, 1.0f);
```

We now calculated all the lighting components of the Phong lighting model. Based on your point of view you should see something like this:

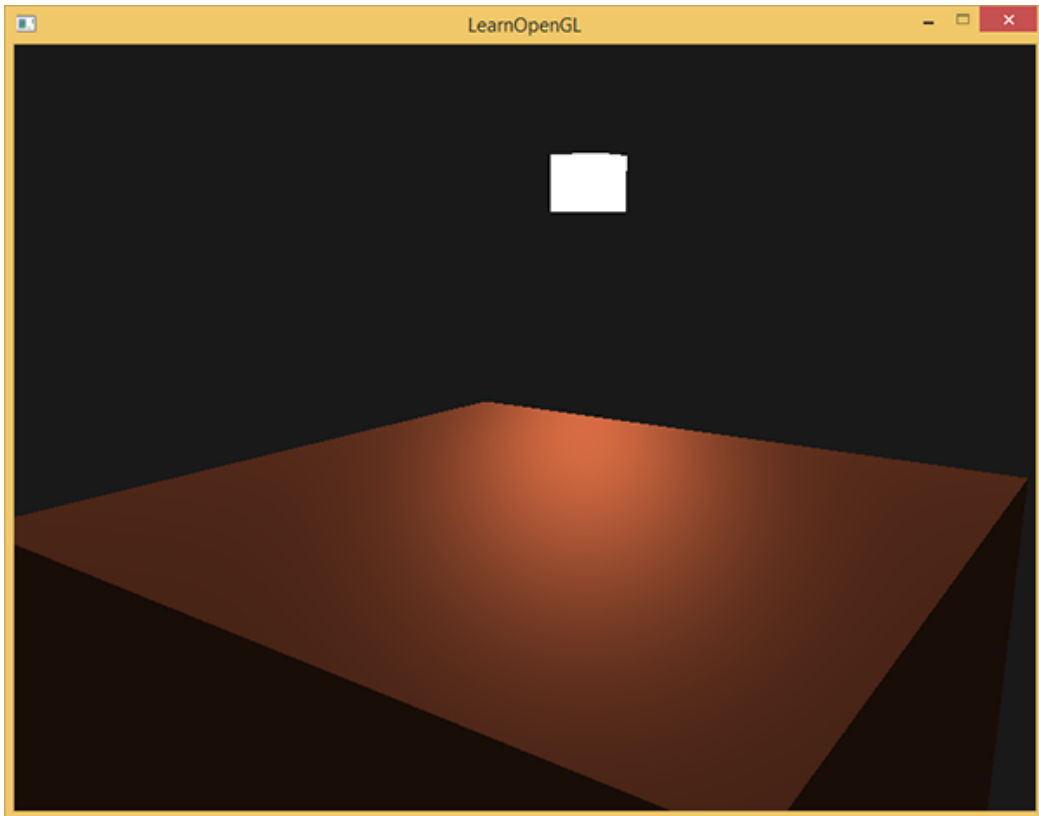

You can find the complete source code of the application [here](#) and the corresponding shaders here: [vertex](#) and [fragment](#).

In the earlier days of lighting shaders, developers used to implement the Phong lighting model in the vertex shader. The advantage of doing lighting in the vertex shader is that it is a lot more efficient since there are generally a lot less vertices than fragments, so the (expensive) lighting calculations are done less frequently. However, the resulting color value in the vertex shader is the resulting lighting color of that vertex only and the color values of the surrounding fragments are then the result of interpolated lighting colors. The result was that the lighting was not very realistic unless large amounts of vertices were used:

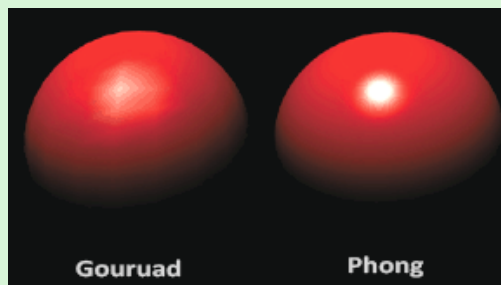

When the Phong lighting model is implemented in the vertex shader it is called **Gouraud shading** instead of **Phong shading**. Note that due to the interpolation the lighting looks a bit off. The Phong shading gives much smoother lighting results.

By now you should be starting to see just how powerful shaders are. With little information shaders are able to calculate how lighting affects the fragment's colors for all our objects. In the [next](#) tutorials we'll be delving much deeper into what we can do with the lighting model.

13.7 Exercises

- Right now the light source is a boring static light source that doesn't move. Try to move the light source around the scene over time using either `sin` or `cos`. Watching the lighting change over time gives you a good understanding of Phong's lighting model: [solution](#).
- Play around with different ambient, diffuse and specular strengths and see how they impact the result. Also experiment with the shininess factor. Try to comprehend why certain values have a certain visual output.
- Do Phong shading in view space instead of world space: [solution](#).
- Implement Gouraud shading instead of Phong shading. If you did things right the lighting should [look a bit off](#) (especially the specular highlights) with the cube object. Try to reason why it looks so weird: [solution](#).



14. Materials

In the real world, each object reacts differently to light. Steel objects are often shinier than a clay vase for example and a wooden container does not react the same to light as a steel container. Each object also responds differently to specular highlights. Some objects reflect the light without too much scattering resulting in a small highlight and others scatter a lot giving the highlight a larger radius. If we want to simulate several types of objects in OpenGL we have to define **material** properties specific to each object.

In the previous tutorial we specified an object and light color to define the visual output of the object, combined with an ambient and specular intensity component. When describing objects we can define a material color for each of the 3 lighting components: ambient, diffuse and specular lighting. By specifying a color for each of the components we have fine-grained control over the color output of the object. Now add a shininess component to those 3 colors and we have all the material properties we need:

```
#version 330 core
struct Material {
    vec3 ambient;
    vec3 diffuse;
    vec3 specular;
    float shininess;
};

uniform Material material;
```

In the fragment shader we create a `struct` to store the material properties of the object. We can also store them as individual uniform values, but storing them as a struct keeps it more organized. We first define the layout of the struct and then simply declare a uniform variable with the newly created struct as its type.

As you can see, we define a color vector for each of the Phong lighting's components. The

`ambient` material vector defines what color this object reflects under ambient lighting; this is usually the same as the object's color. The `diffuse` material vector defines the color of the object under diffuse lighting. The diffuse color is (just like ambient lighting) set to the desired object's color. The `specular` material vector sets the color impact a specular light has on the object (or possibly even reflect an object-specific specular highlight color). Lastly, the `shininess` impacts the scattering/radius of the specular highlight.

With these 4 components that define an object's material we can simulate many real-world materials. A table as found at devernay.free.fr shows several material properties that simulate real materials found in the outside world. The following image shows the effect several of these real world materials have on our cube:

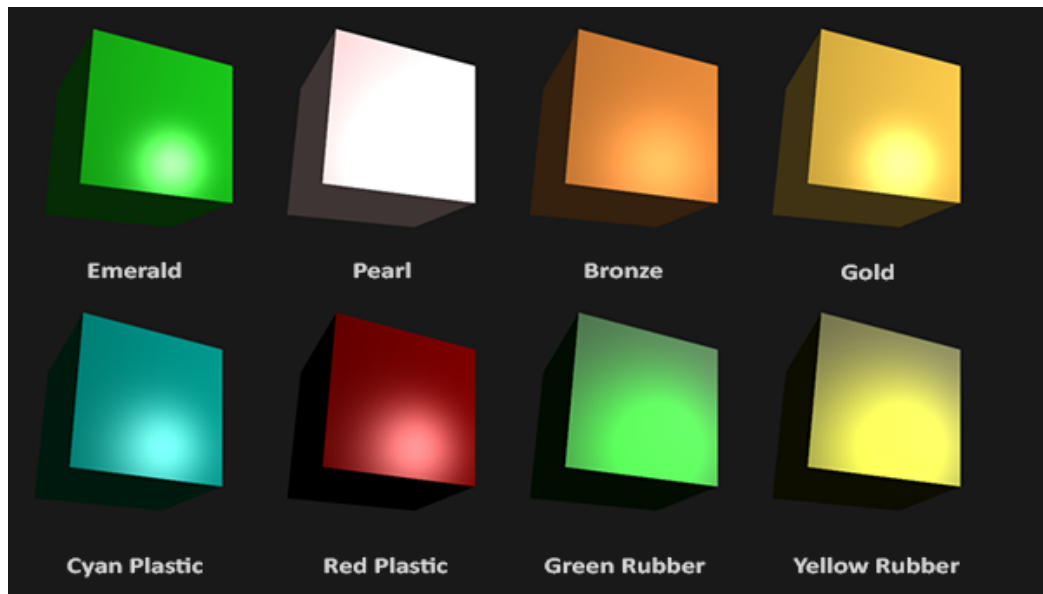

As you can see, by correctly specifying the material properties of an object it seems to change the perception we have of the object. The effects are clearly noticeable, but for the most realistic results we will eventually need more complicated shapes than a cube. In the [following tutorial sections](#) we'll discuss more complicated shapes.

Getting the right materials for an object is a difficult feat that mostly requires experimentation and a lot of experience so it's not that uncommon to completely destroy the visual quality of an object by a misplaced material.

Let's try implementing such a material system in the shaders.

14.1 Setting materials

We created a uniform material struct in the fragment shader so next we want to change the lighting calculations to comply with the new material properties. Since all the material variables are stored in a struct we can access them from the `material` uniform:

```
void main()
{
    // Ambient
```

```

vec3 ambient = lightColor * material.ambient;

// Diffuse
vec3 norm = normalize(Normal);
vec3 lightDir = normalize(lightPos - FragPos);
float diff = max(dot(norm, lightDir), 0.0);
vec3 diffuse = lightColor * (diff * material.diffuse);

// Specular
vec3 viewDir = normalize(viewPos - FragPos);
vec3 reflectDir = reflect(-lightDir, norm);
float spec = pow(max(dot(viewDir, reflectDir), 0.0), material.shininess);
vec3 specular = lightColor * (spec * material.specular);

vec3 result = ambient + diffuse + specular;
color = vec4(result, 1.0f);
}

```

As you can see we now access all of the material struct's properties wherever we need them and this time calculate the resulting output color with the help of the material's colors. Each of the object's material attributes are multiplied with their respective lighting components.

We can set the material of the object in the application by setting the appropriate uniforms. A struct in GLSL however is not special in any regard when setting uniforms. A struct only acts as an encapsulation of uniform variables so if we want to fill the struct we still have to set the individual uniforms, but this time prefixed with the struct's name:

```

GLint matAmbientLoc = glGetUniformLocation(lightningShader.Program, "
    material.ambient");
GLint matDiffuseLoc = glGetUniformLocation(lightningShader.Program, "
    material.diffuse");
GLint matSpecularLoc = glGetUniformLocation(lightningShader.Program, "
    material.specular");
GLint matShineLoc = glGetUniformLocation(lightningShader.Program, "
    material.shininess");

glUniform3f(matAmbientLoc, 1.0f, 0.5f, 0.31f);
glUniform3f(matDiffuseLoc, 1.0f, 0.5f, 0.31f);
glUniform3f(matSpecularLoc, 0.5f, 0.5f, 0.5f);
glUniform1f(matShineLoc, 32.0f);

```

We set the ambient and diffuse component to the color we'd like the object to have and set the specular component of the object to a medium-bright color; we don't want the specular component to be too strong on this specific object. We also keep the shininess at 32. We can now easily influence the object's material from the application.

Running the program gives you something like this:

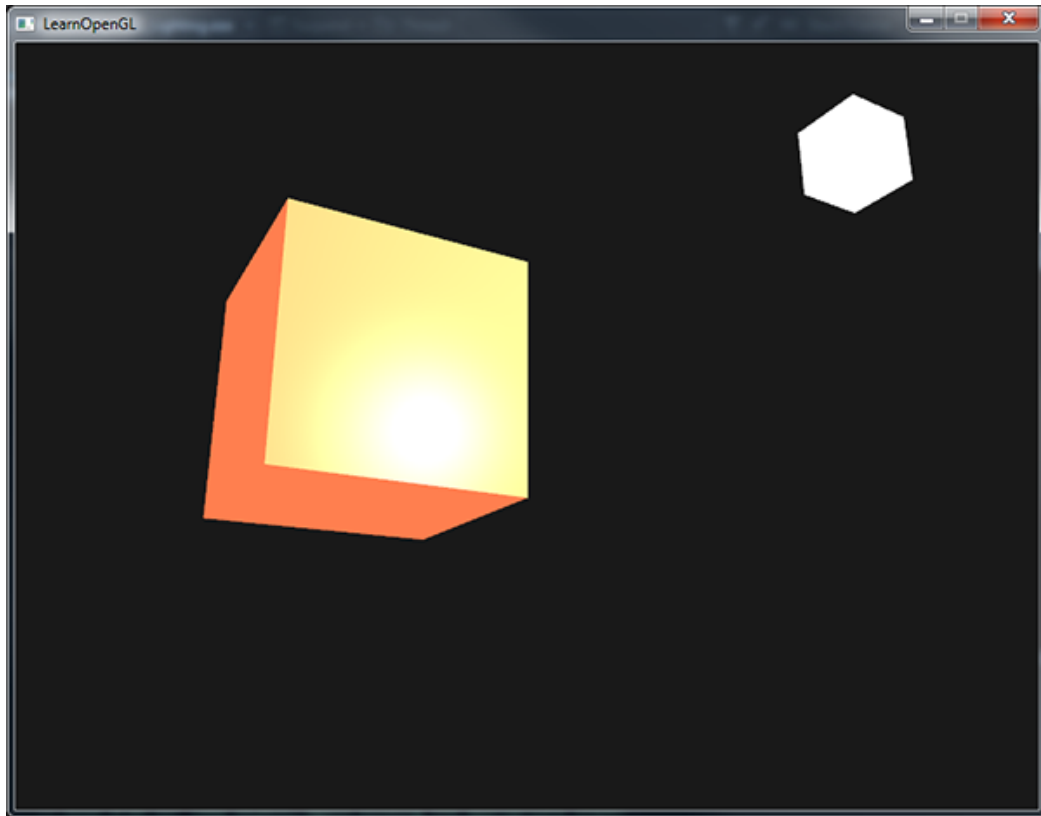

It doesn't really look right though?

14.2 Light properties

The object is way too bright. The reason for the object being too bright is that the ambient, diffuse and specular colors are reflected with full force from any light source. Light sources also have different intensities for their ambient, diffuse and specular components respectively. In the previous tutorial we solved this by varying the ambient and specular intensities with a strength value. We want to do something similar, but this time by specifying intensity vectors for each of the lighting components. If we'd visualize `lightColor` as `vec3(1.0)` the code would look like this:

```
vec3 ambient = vec3(1.0f) * material.ambient;
vec3 diffuse = vec3(1.0f) * (diff * material.diffuse);
vec3 specular = vec3(1.0f) * (spec * material.specular);
```

So each material property of the object is returned with full intensity for each of the light's components. These `vec3(1.0)` values can be influenced individually as well for each light source and this is usually what we want. Right now the ambient component of the object is fully influencing the color of the cube, but the ambient component shouldn't really have such a big impact on the final color so we can restrict the ambient color by setting the light's ambient intensity to a lower value:

```
vec3 result = vec3(0.1f) * material.ambient;
```

We can influence the diffuse and specular intensity of the light source in the same way. This is closely similar to what we did in the previous [previous](#) tutorial; you could say we already created

some light properties to influence each lighting component individually. We'll want to create something similar to the material struct for the light properties:

```
struct Light {
    vec3 position;

    vec3 ambient;
    vec3 diffuse;
    vec3 specular;
};

uniform Light light;
```

A light source has a different intensity for its `ambient`, `diffuse` and `specular` light. The ambient light is usually set to a low intensity because we don't want the ambient color to be too dominant. The diffuse component of a light source is usually set to the exact color we'd like a light to have; often a bright white color. The specular component is usually kept at `vec3(1.0f)` shining at full intensity. Note that we also added the light's position vector to the struct.

Just like with the material uniform we need to update the fragment shader:

```
vec3 ambient = light.ambient * material.ambient;
vec3 diffuse = light.diffuse * (diff * material.diffuse);
vec3 specular = light.specular * (spec * material.specular);
```

We then want to set the light intensities in the application:

```
GLint lightAmbientLoc = glGetUniformLocation(lightningShader.Program, "light
.ambient");
GLint lightDiffuseLoc = glGetUniformLocation(lightningShader.Program, "light
.diffuse");
GLint lightSpecularLoc = glGetUniformLocation(lightningShader.Program, "
light.specular");

glUniform3f(lightAmbientLoc, 0.2f, 0.2f, 0.2f);
glUniform3f(lightDiffuseLoc, 0.5f, 0.5f, 0.5f); // Let's darken the light a
bit to fit the scene
glUniform3f(lightSpecularLoc, 1.0f, 1.0f, 1.0f);
```

Now that we modulated how the light influences all the objects' materials we get a visual output that looks much like the output from the previous tutorial. This time however we got full control over the lighting and the material of the object:

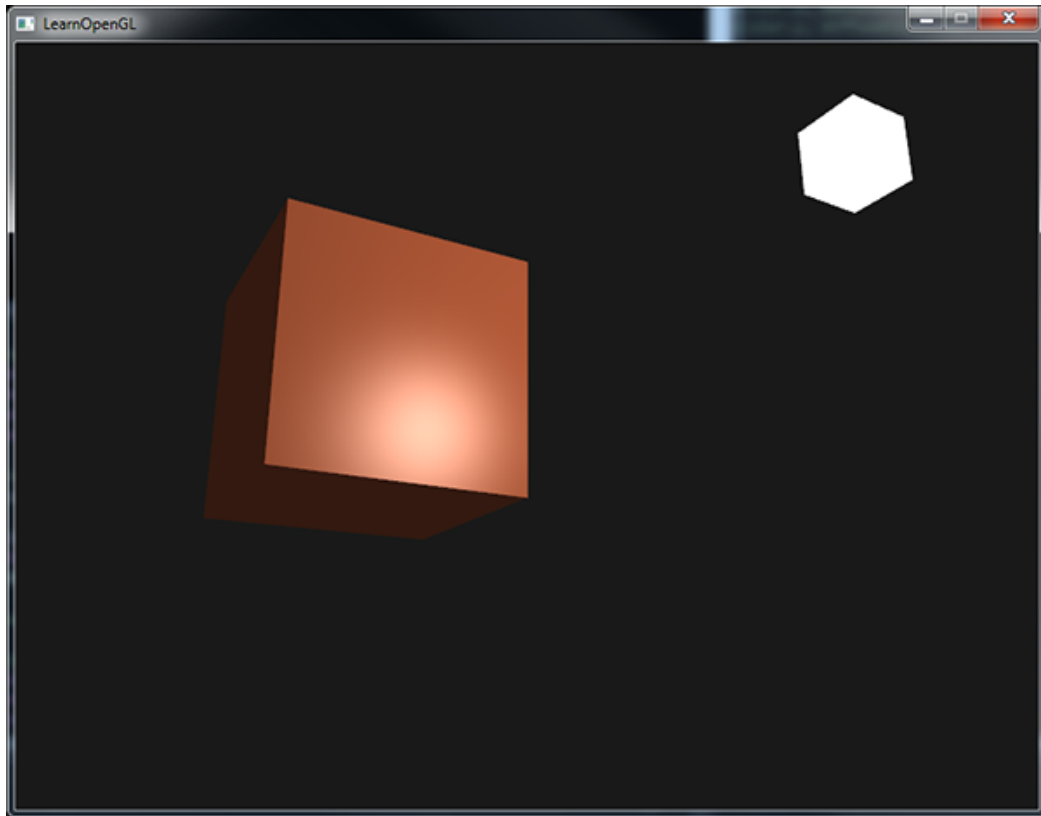

Changing the visual aspects of objects is relatively easy right now. Let's spice things up a bit!

14.3 Different light colors

So far we used light colors to only vary the intensity of their individual components by choosing colors that range from white to gray to black, not affecting the actual colors of the object (only its intensity). Since we now have easy access to the light's properties we can change their colors over time to get some really interesting effects. Since everything is already set up in the fragment shader, changing the light's colors is easy and immediately creates some funky effects:

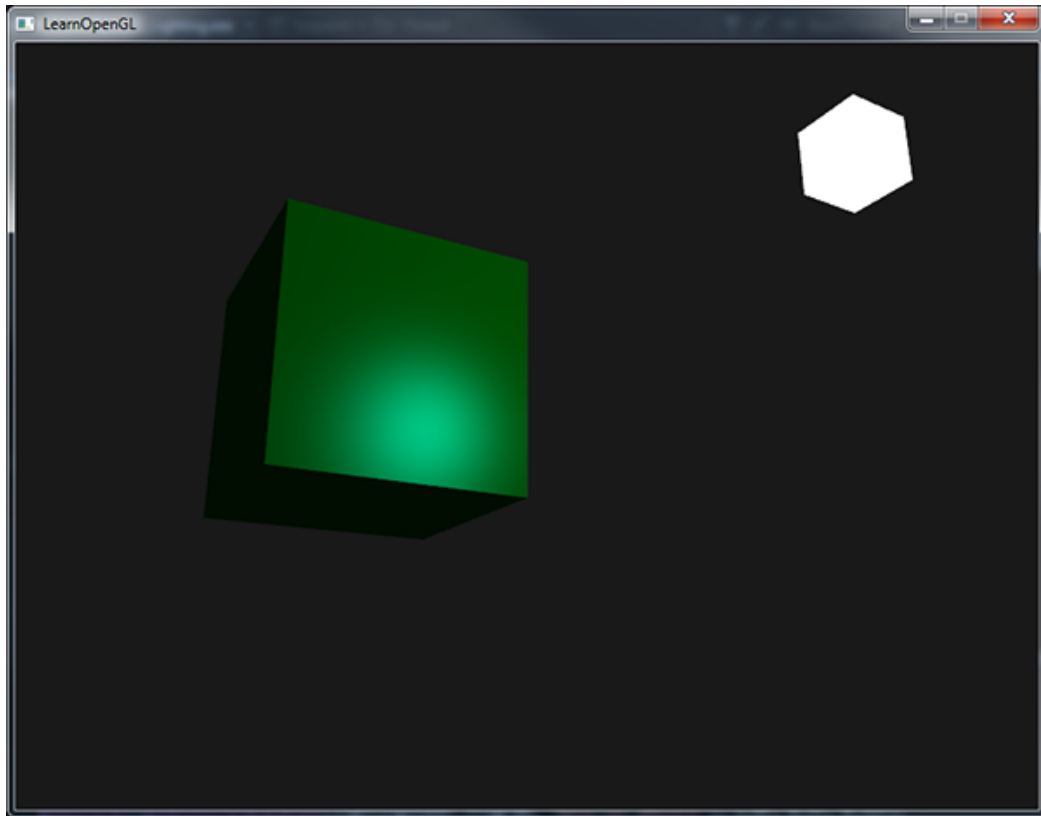

As you can see, a different light color greatly influences the object's color output. Since the light color directly influences what colors the object can reflect (as you might remember from the [Colors](#) tutorial) it has a significant impact on the visual output.

We can easily change the light's colors over time by changing the light's ambient and diffuse colors via `sin` and `glfwGetTime`:

```
glm::vec3 lightColor;
lightColor.x = sin(glfwGetTime() * 2.0f);
lightColor.y = sin(glfwGetTime() * 0.7f);
lightColor.z = sin(glfwGetTime() * 1.3f);

glm::vec3 diffuseColor = lightColor * glm::vec3(0.5f); // Decrease the
    influence
glm::vec3 ambientColor = diffuseColor * glm::vec3(0.2f); // Low influence

glUniform3f(lightAmbientLoc, ambientColor.x, ambientColor.y, ambientColor.z
    );
glUniform3f(lightDiffuseLoc, diffuseColor.x, diffuseColor.y, diffuseColor.z
    );
```

Try and experiment with several lighting and material values and see how they affect the visual output. You can find the source code of the application [here](#) and the fragment shader [here](#).

14.4 Exercises

- Can you simulate some of the real-world objects by defining their respective materials like we've seen at the start of this tutorial? Note that the [table](#)'s ambient values are not the same

as the diffuse values; they didn't take light intensities into account. To correctly set their values you'd have to set all the light intensities to `vec3(1.0f)` to get the same output: [solution](#) of cyan plastic container.

A futuristic cityscape with a flying vehicle in the foreground. The vehicle is dark with blue glowing lights and is flying towards the left. The city in the background is dense with tall, thin buildings and a hazy atmosphere.

15. Lighting maps

In the [previous](#) tutorial we discussed the possibility of each object having a unique material of its own that reacts differently to light. This is great for giving each object a unique look in comparison with other objects in a lighted scene, but still doesn't offer too much flexibility on the visual output of an object.

In the previous tutorial we defined a material for an entire object as a whole, but objects in the real world usually do not consist of a single material, but consist of several materials. Think of a car: its exterior consists of a shiny fabric, it has windows that partly reflect the surrounding environment, its tires are all but shiny so they don't have specular highlights and it has rims that are super shiny (if you actually washed your car alright). The car also has diffuse and ambient colors that are not the same for the entire object; a car displays many different ambient/diffuse colors. All by all, such an object has different material properties for each of its different parts.

So the material system in the previous tutorial isn't sufficient for all but the simplest models so we need to extend the previous system by introducing *diffuse* and *specular* maps. These allow us to influence the diffuse (and indirectly the ambient component since they're almost always the same anyways) and the specular component of an object with much more precision.

15.1 Diffuse maps

What we want is some way to set the diffuse color of an object for each individual fragment. Some sort of system where we can retrieve a color value based on the fragment's position on the object?

This should probably all sound extremely familiar and to be honest we've been using such a system for a while now. This sounds a lot like *textures* we've extensively discussed in one of the [earlier](#) tutorials and it basically is just that: a texture. We're just using a different name for the same underlying principle: using an image wrapped around an object that we can index for unique color

values per fragment. In lighted scenes this is usually called a **diffuse map** (this is generally how 3D artists call them) since a texture image represents all of the object's diffuse colors.

To demonstrate diffuse maps we're going to use the [following image](#) of a wooden container with a steel border:



Using a diffuse map in shaders is exactly the same as with the texture tutorials. This time however we store the texture as a `sampler2D` inside the `Material` struct. We replace the earlier defined `vec3` diffuse color vector with the diffuse map.

Keep in mind that `sampler2D` is a so called **opaque type** which means we can't instantiate these types, but only define them as uniforms. If we would instantiate this struct other than as a uniform (like a function parameter) GLSL could throw strange errors; the same thus applies to any struct holding such opaque types.

We also remove the ambient material color vector since the ambient color is in almost all cases equal to the diffuse color so there's no need to store it separately:

```
struct Material {
    sampler2D diffuse;
    vec3      specular;
    float     shininess;
};
...
in vec2 TexCoords;
```

If you're a bit stubborn and still want to set the ambient colors to a different value (other than the diffuse value) you can keep the ambient `vec3`, but then the ambient colors would still remain the same for the entire object. To get different ambient values for each fragment you'd have to use another texture for ambient values alone.

Note that we are going to need texture coordinates again in the fragment shader, so we declared an extra input variable. Then we simply sample from the texture to retrieve the fragment's diffuse color value:

```
vec3 diffuse = light.diffuse * diff * vec3(texture(material.diffuse,
    TexCoords));
```

Also, don't forget to set the ambient material's color equal to the diffuse material's color as well:

```
vec3 ambient = light.ambient * vec3(texture(material.diffuse, TexCoords));
```

And that's all it takes to use a diffuse map. As you can see it is nothing new, but it does provide a dramatic increase in visual quality. To get it working we do need to update the vertex data with texture coordinates, transfer them as vertex attributes to the fragment shader, load the texture and bind the texture to the appropriate texture unit.

The updated vertex data can be found [here](#). The vertex data now includes vertex positions, normal vectors and texture coordinates for each of the cube's vertices. Let's update the vertex shader to accept texture coordinates as a vertex attribute and forward them to the fragment shader:

```
#version 330 core
layout (location = 0) in vec3 position;
layout (location = 1) in vec3 normal;
layout (location = 2) in vec2 texCoords;
...
out vec2 TexCoords;

void main()
{
    ...
    TexCoords = texCoords;
}
```

Be sure to update the vertex attribute pointers of both VAOs to match the new vertex data and load the container image as a texture. Before drawing the container we want to assign the preferred texture unit to the `material.diffuse` uniform sampler and bind the container texture to this texture unit:

```
glUniform1i(glGetUniformLocation(lightningShader.Program, "material.diffuse"
    ), 0);
...
glActiveTexture(GL_TEXTURE0);
glBindTexture(GL_TEXTURE_2D, diffuseMap);
```

Now using a diffuse map we get an enormous boost in detail again and this time with added lighting the container really starts to shine (quite literally). Your container now probably looks something like this:



You can find the full source code of the application [here](#).

15.2 Specular maps

You probably noticed that the specular highlight looks a bit off since our object is a container that mostly consists of wood and we know that wood doesn't give such specular highlights. We can fix this by setting the specular material of the object to `vec3(0.0f)` but that would mean that the steel borders of the container would stop showing specular highlights as well and we also know that steel **should** show some specular highlights. Again, we would like to control what parts of the object should show a specular highlight with varying intensity. This is a problem that looks really familiar to the diffuse maps discussion. Coincidence? I think not.

We can also use a texture map just for specular highlights. This means we need to generate a black and white (or colors if you feel like it) texture that defines the specular intensities of each part of the object. An example of a [specular map](#) is the following image:

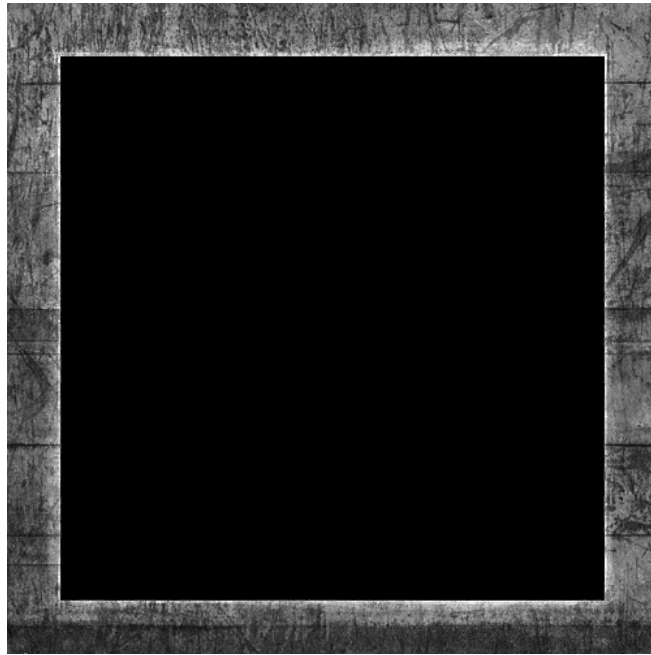

The intensity of a specular highlight is retrieved by the brightness of each pixel in the image. Each pixel of the specular map can be displayed as a color vector where black represents the color vector `vec3(0.0f)` and gray the color vector `vec3(0.5f)` for example. In the fragment shader we then sample the corresponding color value and multiply this value with the light's specular intensity. The more 'white' a pixel thus is, the higher the result of the multiplication and thus the brighter the specular component of an object becomes.

Because the container mostly consists of wood, and wood as a material should have no specular highlights, the entire wooden section of the diffuse texture was converted to black: black sections do not have any specular highlight. The steel border of the container has varying specular intensities with the steel itself being relatively susceptible to specular highlights while the cracks are not.

Technically wood also has specular highlights although with a much lower shininess value (more light scattering) and less impact, but for learning purposes we can just pretend wood doesn't have any reaction to specular light.

Using tools like *Photoshop* or *Gimp* it is relatively easy to transform a diffuse texture to a specular image like this by cutting out some parts, transforming it to black and white and increasing the brightness/contrast.

15.3 Sampling specular maps

A specular map is just like any other texture so the code is similar to the diffuse map code. Make sure to properly load the image and generate a texture object. Since we're using another texture sampler in the same fragment shader we have to use a different texture unit (see [Textures](#)) for the specular map so let's bind it to the appropriate texture unit before rendering:

```
glUniform1i(glGetUniformLocation(lightningShader.Program, "material.specular"), 1);
```

```
...
glActiveTexture(GL_TEXTURE1);
glBindTexture(GL_TEXTURE_2D, specularMap);
```

Then update the material properties of the fragment shader to accept a `sampler2D` as its specular component instead of a `vec3`:

```
struct Material {
    sampler2D diffuse;
    sampler2D specular;
    float    shininess;
};
```

And lastly we want to sample the specular map to retrieve the fragment's corresponding specular intensity:

```
vec3 ambient = light.ambient * vec3(texture(material.diffuse, TexCoords));
vec3 diffuse = light.diffuse * diff * vec3(texture(material.diffuse,
    TexCoords));
vec3 specular = light.specular * spec * vec3(texture(material.specular,
    TexCoords));
color = vec4(ambient + diffuse + specular, 1.0f);
```

By using a specular map we can specify with enormous detail what parts of an object actually have *shiny* properties and we can even set their corresponding intensity. Specular maps thus give us an added layer of control on top of the diffuse map.

If you don't want to be too mainstream you could also use actual colors in the specular map to not only set the specular intensity of each fragment, but also the color of the specular highlight. Realistically, however, the color of the specular highlight is mostly (to completely) determined by the light source itself so it wouldn't generate realistic visuals (that's why the images are usually black and white: we only care about the intensity).

If you would now run the application you can clearly see that the container's material now closely resembles that of an actual wooden container with steel frames:

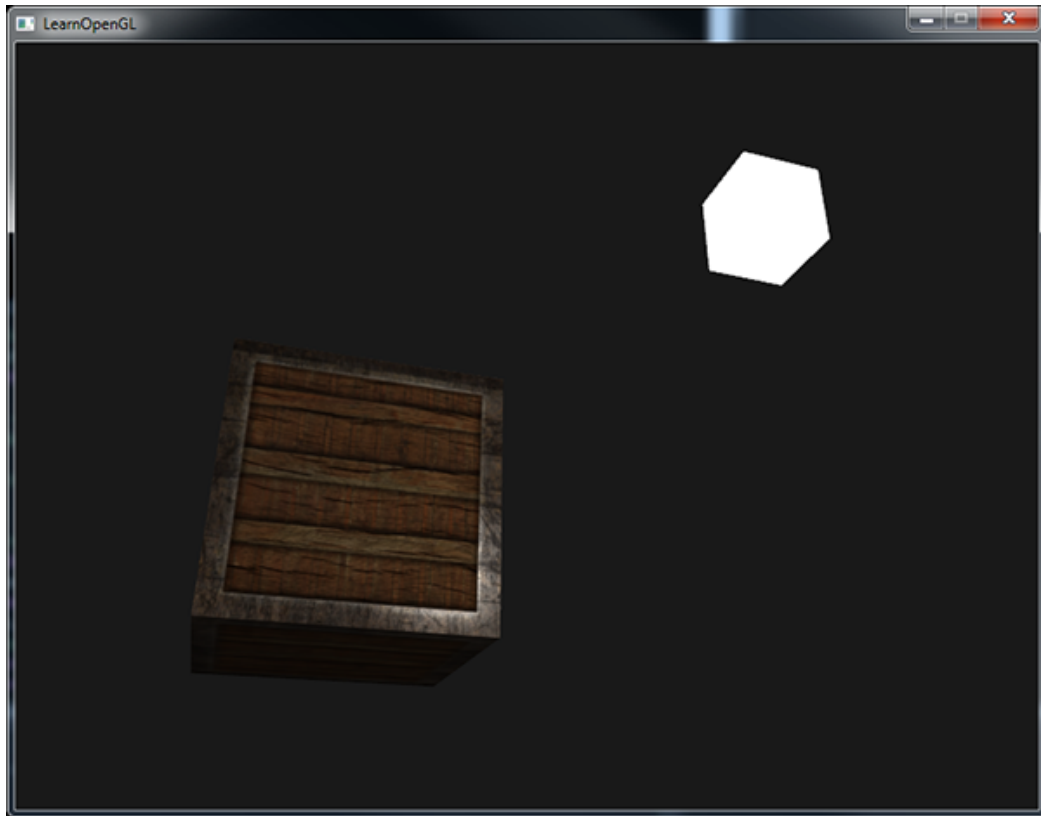

You can find the full source code of the application [here](#). Also compare your shaders with the [vertex](#) and the [fragment](#) shader.

Using diffuse and specular maps we can really add an enormous amount of detail into relatively simple objects. We can even add more detail into the objects using other texture maps like [normal/bump maps](#) and/or [reflection maps](#), but that is something we'll reserve for later tutorials. Show your container to all your friends and family and be content with the fact that our container can one day become even prettier than it already is!

15.4 Exercises

- Fool around with the light source's ambient, diffuse and specular vectors and see how they affect the visual output of the container.
- Try inverting the color values of the specular map in the fragment shader so that the wood shows specular highlights and the steel borders do not (note that due to the cracks in the steel border the borders still show some specular highlight, although with less intensity): [solution](#).
- Try creating a specular map from the diffuse texture that uses actual colors instead of black and white and see that the result doesn't look too realistic. You can use this [colored specular map](#) if you can't generate one yourself: [result](#).
- Also add something they call an [emission map](#) which is a texture that stores emission values per fragment. Emission values are colors an object might *emit* as if it contains a light source itself; this way an object can glow regardless of the light conditions. Emission maps are often what you see when objects in a game glow (like [eyes of a robot](#), or [light strips on a container](#)). Add the [following](#) texture (by creativesam) as an emission map onto the container as if the letters emit light: [solution](#), [fragment shader](#); [result](#).



16. Light casters

All the lighting we've used so far came from a single source that is a single point in space. It gives good results, but in the real world we have several types of light that each act different. A light source that *casts* light upon objects is called a **light caster**. In this tutorial we'll discuss several different types of light casters. Learning to simulate different light sources is yet another tool in your toolbox to further enrich your environments.

We'll first discuss a directional light, then a point light which is an extension of what we had before and lastly we'll discuss spotlights. In the [next](#) tutorial we'll combine several of these different light types into one scene.

16.1 Directional Light

When a light source is far away the light rays coming from the light source are close to parallel to each other. It looks like all the light rays are coming from the same direction, regardless of where the object and/or the viewer is. When a light source is modeled to be *infinitely* far away it is called a **directional light** since all its light rays have the same direction; it is independent of the location of the light source.

A fine example of a directional light source is the sun as we know it. The sun is not infinitely far away from us, but it is so far away that we can perceive it as being infinitely far away in the lighting calculations. All the light rays from the sun are then modelled as parallel light rays as we can see in the following image:

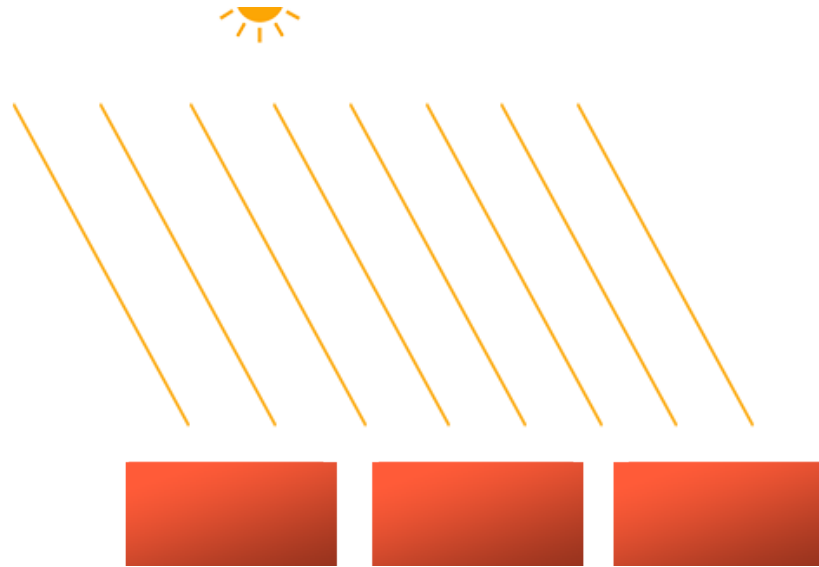

Because all the light rays are parallel it does not matter how each object relates to the light source's position since the light direction remains the same for each object in the scene. Because the light's direction vector stays the same, the lighting calculations will be similar for each object in the scene.

We can model such a directional light by defining a light direction vector instead of a position vector. The shader calculations remain mostly the same except this time we directly use the light's `direction` vector instead of calculating the `lightDir` vector with the light's `position` vector:

```
struct Light {
    // vec3 position; // No longer necessary when using directional lights.
    vec3 direction;

    vec3 ambient;
    vec3 diffuse;
    vec3 specular;
};
...
void main()
{
    vec3 lightDir = normalize(-light.direction);
    ...
}
```

Note that we first negate the `light.direction` vector. The lighting calculations we used so far expect the light direction to be a direction from the fragment **towards** the light source, but people generally prefer to specify a directional light as a global direction pointing **from** the light source. Therefore we have to negate the global light direction vector to switch its direction; it's now a direction vector pointing towards the light source. Also, be sure to normalize the vector since it is unwise to assume the input vector to be a unit vector.

The resulting `lightDir` vector is then used as before in the diffuse and specular computations.

To clearly demonstrate that a directional light has the same effect on all multiple objects we

revisit the container party scene from the end of the [Coordinate systems](#) tutorial. In case you missed the party we first defined 10 different [container positions](#) and generated a different model matrix per container where each model matrix contained the appropriate local-to-world transformations:

```
for(GLuint i = 0; i < 10; i++)
{
    model = glm::mat4();
    model = glm::translate(model, cubePositions[i]);
    GLfloat angle = 20.0f * i;
    model = glm::rotate(model, angle, glm::vec3(1.0f, 0.3f, 0.5f));
    glUniformMatrix4fv(modelLoc, 1, GL_FALSE, glm::value_ptr(model));

    glDrawArrays(GL_TRIANGLES, 0, 36);
}
```

Also, don't forget to actually specify the direction of the light source (note that we define the direction as a direction **from** the light source; you can quickly see the light's direction is pointing downwards):

```
GLint lightDirPos = glGetUniformLocation(lightningShader.Program, "light.
    direction");
glUniform3f(lightDirPos, -0.2f, -1.0f, -0.3f);
```

We've been passing the light's position and direction vectors as `vec3s` for a while now, but some people tend to prefer to keep all the vectors defined as `vec4`. When defining position vectors as a `vec4` it is important to set the `w` component to `1.0` so translation and projections are properly applied. However, when defining a direction vector as a `vec4` we don't want translations to have an effect (since they just represent directions, nothing more) so then we define the `w` component to be `0.0`.

Direction vectors are then represented like: `vec4(0.2f, 1.0f, 0.3f, 0.0f)`. This can also function as an easy check for light types: you could check if the `w` component is equal to `1.0` to see that we now have a light's position vector and if `w` is equal to `0.0` we have a light's direction vector so adjust the calculations based on that:

```
if(lightVector.w == 0.0) // Note: be careful for floating point errors
// Do directional light calculations
else if(lightVector.w == 1.0)
// Do light calculations using the light's position (like last
    tutorial)
```

Fun fact: this is actually how the old OpenGL (fixed-functionality) determined if a light source was a directional light or a positional light source and adjusted its lighting based on that.

If you'd now compile the application and fly through the scene it looks like there is a sun-like light source casting light on all the objects. Can you see that the diffuse and specular components all react as if there was a light source somewhere in the sky? It'll look something like this:

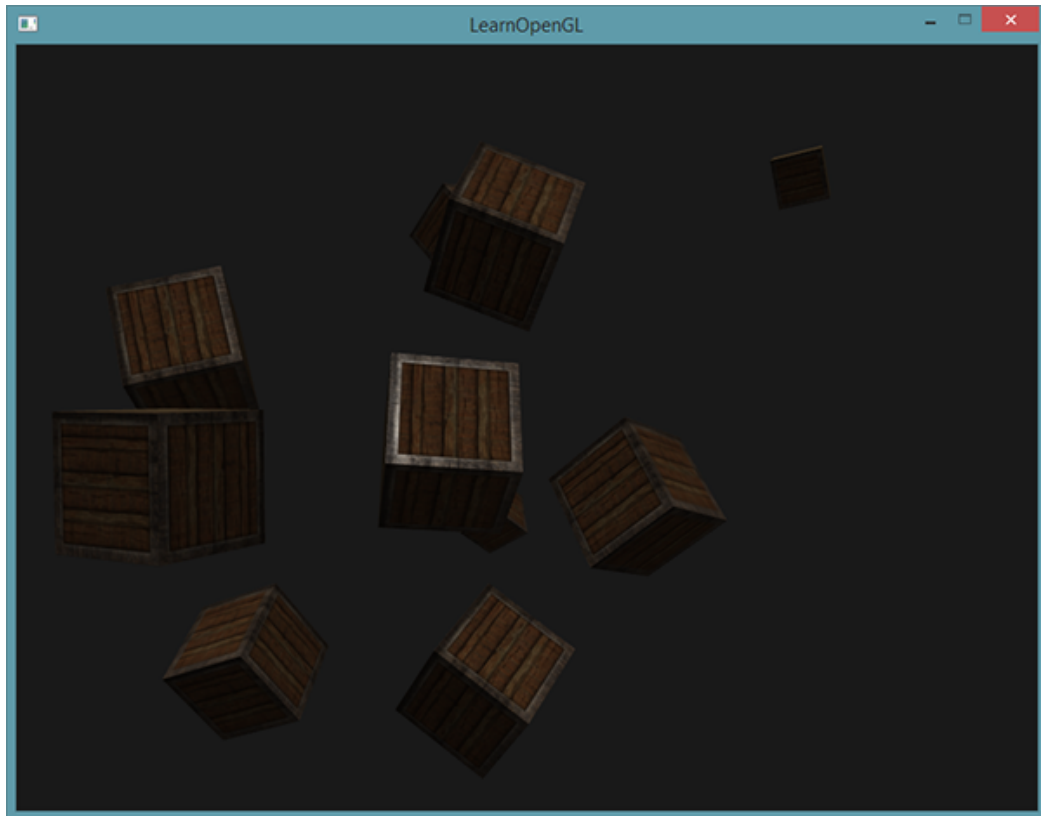

You can find the full source code of the application [here](#) together with the [vertex](#) and [fragment](#) shader's code.

16.2 Point lights

Directional lights are great for global lights that illuminate the entire scene, but aside from a directional light we usually also want several [point lights](#) scattered throughout the scene. A point light is a light source with a given position somewhere in a world that illuminates in all directions where the light rays fade out over distance. Think of light bulbs and torches as light casters that act as a point light.

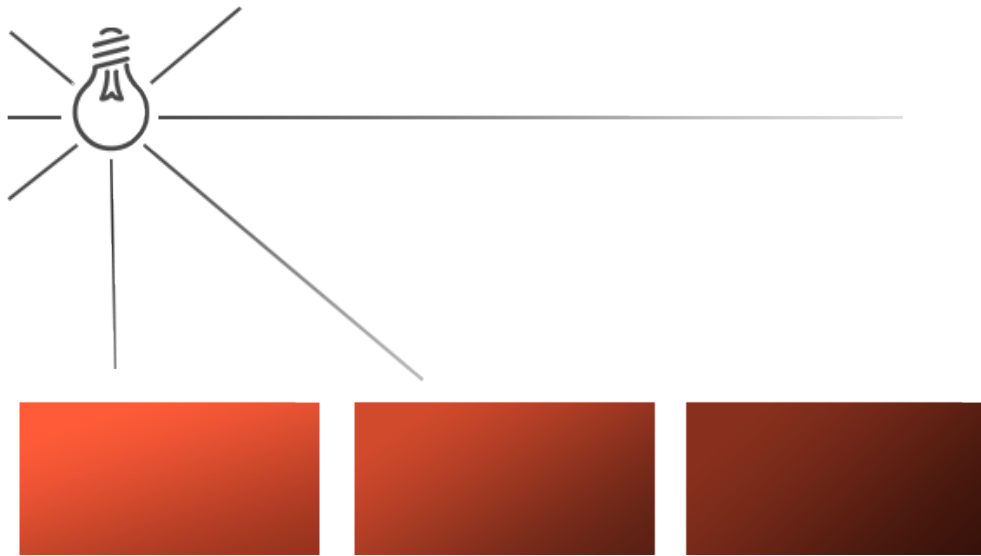

In the earlier tutorials we've been working with a (simplistic) point light all along. We had a light source at a given position that scatters light in all directions from that given light position. However, the light source we defined simulated light rays that never fade out thus making it look like the light source is extremely strong. In most 3D simulations we'd like to simulate a light source that only illuminates a certain area close to the light source and not the entire scene.

If you'd add the 10 containers to the lighting scene of the previous tutorial you'd notice that the container all the way in the back is lit with the same intensity as the container in front of the lamp; there is no formula defined that diminishes light over distance. We want the container in the back to only be slightly lit in comparison to the containers close to the light source.

16.3 Attenuation

To reduce the intensity of light, over the distance a light ray travels, is generally called **attenuation**. One way to reduce the light intensity over distance is to simply use a linear equation. Such an equation would linearly reduce the light intensity over the distance thus making sure that objects at a distance are less bright. However, such a linear function tends to look a bit fake. In the real world, lights are generally quite bright standing close by, but the brightness of a light source diminishes quickly at the start and the remaining light intensity more slowly diminishes over distance. We are thus in need of a different formula for reducing the light's intensity.

Luckily some smart people already figured this out for us. The following formula divides the light's intensity of a fragment by a calculated attenuation value based on the distance to the light source:

$$F_{att} = \frac{I}{K_c + K_l * d + K_q * d^2} \quad (16.1)$$

Here I is the intensity of the light at the current fragment and d represents the distance from the fragment to the light source. Then to calculate the attenuation value we define 3 (configurable) terms: a **constant** term K_c , a **linear** term K_l and a **quadratic** term K_q .

- The constant term is usually kept at 1.0 which is mainly there to make sure the resulting denominator never gets smaller than 1 since it would otherwise boost the intensity with certain distances, which is not the effect we're looking for.
- The linear term is multiplied with the distance value that reduces the intensity in a linear fashion.
- The quadratic term is multiplied with the quadrant of the distance and sets a quadratic decrease of intensity for the light source. The quadratic term will be less significant compared to the linear term when the distance is small, but gets much larger than the linear term as the distance grows.

Due to the quadratic term the light will diminish mostly at a linear fashion until the distance becomes large enough for the quadratic term to surpass the linear term and then the light intensity will decrease a lot faster. The resulting effect is that the light is quite intense when at a close range, but quickly loses its brightness over distance and eventually loses its brightness at a more slower pace. The following graph shows the effect such an attenuation has over a distance of 100:

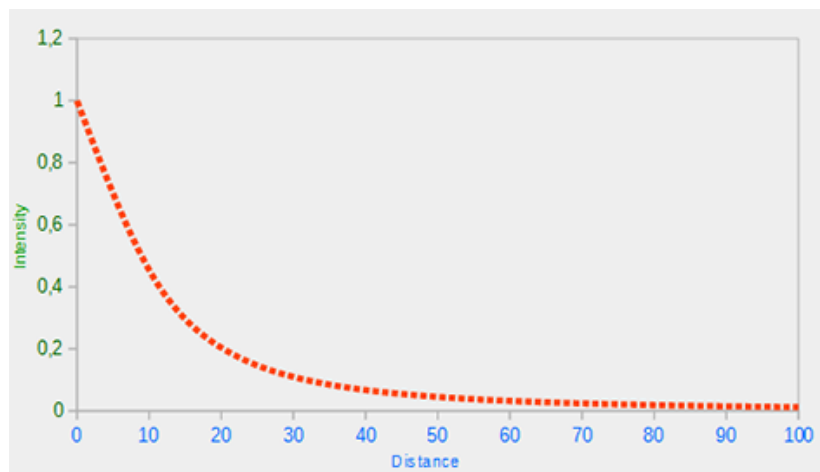

You can see that the light has the highest intensity when the distance is small, but as soon as the distance grows its intensity is significantly reduced and slowly reaches 0 intensity at around a distance of 100. This is exactly what we want.

16.3.1 Choosing the right values

But at what values do we set those 3 terms? Setting the right values depends on many factors: the environment, the distance you want a light to cover, the type of light etc. In most cases, it simply is a question of experience and a moderate amount of tweaking. The following table shows some of the values these terms could take to simulate a realistic (sort of) light source that covers a specific radius (distance). The first column specifies the distance a light will cover with the given terms. These values are good starting points for most lights, with courtesy of [Ogre3D's wiki](#):

Distance	Constant	Linear	Quadratic
7	1.0	0.7	1.8
13	1.0	0.35	0.44
20	1.0	0.22	0.20
32	1.0	0.14	0.07
50	1.0	0.09	0.032
65	1.0	0.07	0.017
100	1.0	0.045	0.0075
160	1.0	0.027	0.0028
200	1.0	0.022	0.0019
325	1.0	0.014	0.0007
600	1.0	0.007	0.0002
3250	1.0	0.0014	0.000007

As you can see, the constant term K_c is kept at 1.0 in all cases. The linear term K_l is usually quite small to cover larger distances and the quadratic term K_q is even smaller. Try to experiment a bit with these values to see their effect in your implementation. In our environment a distance of 32 to 100 is generally enough for most lights.

16.3.2 Implementing attenuation

To implement attenuation we'll be needing 3 extra values in the fragment shader: namely the constant, linear and quadratic terms of the formula. These are best stored in the `Light` struct we defined earlier. Note that we calculate `lightDir` as we did in the previous tutorial and not as in the earlier *Directional Light* section.

```
struct Light {
    vec3 position;

    vec3 ambient;
    vec3 diffuse;
    vec3 specular;

    float constant;
    float linear;
    float quadratic;
};
```

Then we set the terms in OpenGL: we want the light to cover a distance of 50 so we'll use the appropriate constant, linear and quadratic terms from the table:

```
glUniform1f(glGetUniformLocation(lightningShader.Program, "light.constant"),
            1.0f);
glUniform1f(glGetUniformLocation(lightningShader.Program, "light.linear"),
            0.09);
glUniform1f(glGetUniformLocation(lightningShader.Program, "light.quadratic"),
            0.032);
```

Implementing attenuation in the fragment shader is relatively straightforward: we simply calculate an attenuation value based on the formula and multiply this with the ambient, diffuse and specular components.

We do need the distance to the light source for the formula to work though; remember how we can calculate the length of a vector? We can retrieve the distance term by retrieving the difference vector between the fragment and the light source and take the resulting vector's length. We can use GLSL's built-in `length` function for that purpose:

```
float distance    = length(light.position - Position);
float attenuation = 1.0f / (light.constant + light.linear * distance +
                           light.quadratic * (distance * distance));
```

Then we include this attenuation value in the lighting calculations by multiplying the attenuation value with the ambient, diffuse and specular colors.

We could leave the ambient component alone so ambient lighting is not decreased over distance, but if we were to use more than 1 light source all the ambient components will start to stack up so in that case we want to attenuate ambient lighting as well. Simply play around with what's best for your environment.

```
ambient *= attenuation;
diffuse *= attenuation;
specular *= attenuation;
```

If you'd run the application you'd get something like this:

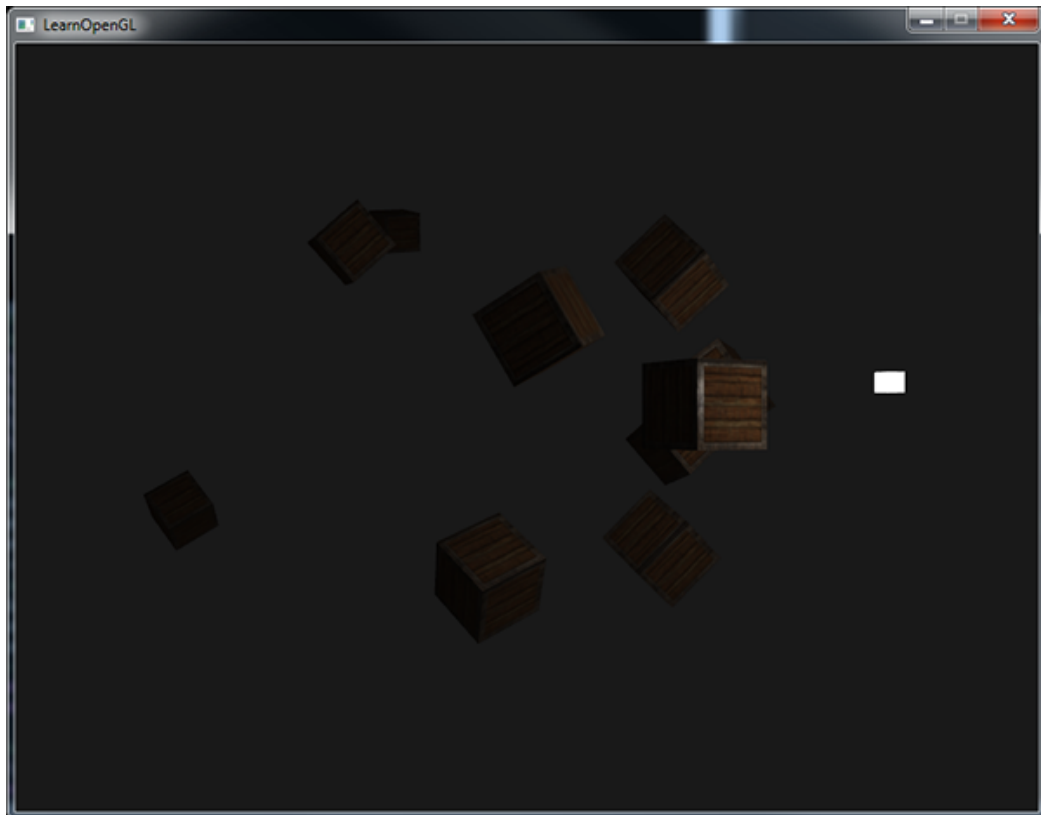

You can see that right now only the front containers are lit with the closest container being the brightest. The containers in the back are not lit at all since they're too far from the light source. You can find the source code of the application [here](#) and the fragment's code [here](#).

A point light is thus a light source with a configurable location and attenuation applied to its lighting calculations. Yet another type of light for our lighting arsenal.

16.4 Spotlight

The last type of light we're going to discuss is a **spotlight**. A spotlight is a light source that is located somewhere in the environment that, instead of shooting light rays in all directions, only shoots them in a specific direction. The result is that only the objects within a certain radius of the spotlight's direction are lit and everything else stays dark. A good example of a spotlight would be a street lamp or a flashlight.

A spotlight in OpenGL is represented by a world-space position, a direction and a **cutoff** angle that specifies the radius of the spotlight. For each fragment we calculate if the fragment is between the spotlight's cutoff directions (thus in its cone) and if so, we lit the fragment accordingly. The following image gives you an idea of how a spotlight works:

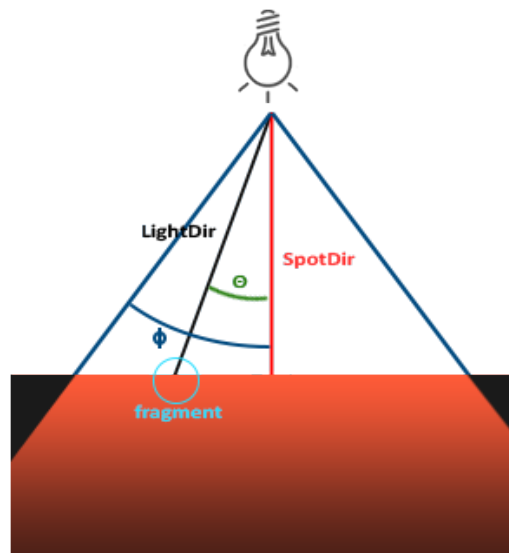

- `LightDir`: the vector pointing from the fragment to the light source.
- `SpotDir`: the direction the spotlight is aiming at.
- Phi ϕ : the cutoff angle that specifies the spotlight's radius. Everything outside this angle is not lit by the spotlight.
- Theta θ : the angle between the `LightDir` vector and the `SpotDir` vector. The θ value should be smaller than the Φ value to be inside the spotlight.

So what we basically need to do, is calculate the dot product (returns the cosine of the angle between two unit vectors remember?) between the `LightDir` vector and the `SpotDir` vector and compare this with the cutoff angle ϕ . Now that you (sort of) understand what a spotlight is all about we're going to create one in the form of a flashlight.

16.5 Flashlight

A flashlight is a spotlight located at the viewer's position and usually aimed straight ahead from the player's perspective. Basically a flashlight is a normal spotlight, but with its position and direction

continually updated based on the player's position and orientation.

So, the values we're going to need for the fragment shader are the spotlight's position vector (to calculate the light's direction vector), the spotlight's direction vector and the cutoff angle. We can store these values in the `Light` struct:

```
struct Light {
    vec3 position;
    vec3 direction;
    float cutOff;
    ...
};
```

Next we pass the appropriate values to the shaders:

```
glUniform3f(lightPosLoc, camera.Position.x, camera.Position.y,
            camera.Position.z);
glUniform3f(lightSpotdirLoc, camera.Front.x, camera.Front.y, camera.
            Front.z);
glUniform1f(lightSpotCutOffLoc, glm::cos(glm::radians(12.5f)));
```

As you can see we're not setting an angle for the cutoff value but calculate the cosine value based on an angle and pass the cosine result to the fragment shader. The reason for this is that in the fragment shader we're calculating the dot product between the `LightDir` and the `SpotDir` vector and the dot product returns a cosine value and not an angle so we can't directly compare an angle with a cosine value. To retrieve the angle we then have to calculate the inverse cosine of the dot product's result which is an expensive operation. So to save some performance we calculate the cosine value of a given cutoff angle and pass this result to the fragment shader. Since both angles are now represented as cosines, we can directly compare between them without any expensive operations.

Now what's left to do is calculate the theta θ value and compare this with the cutoff ϕ value to determine if we're in or outside the spotlight:

```
float theta = dot(lightDir, normalize(-light.direction));

if(theta > light.cutOff)
{
    // Do lighting calculations
}
else // else, use ambient light so scene isn't completely dark outside the
    spotlight.
color = vec4(light.ambient * vec3(texture(material.diffuse, TexCoords)),
            1.0f);
```

We first calculate the dot product between the `lightDir` vector and the negated `direction` vector (negated, because we want the vectors to point towards the light source, instead of from). Be sure to normalize all the relevant vectors.

You might be wondering why there is a $>$ sign instead of a $<$ sign in the `if` guard. Shouldn't `theta` be smaller than the light's cutoff value to be inside the spotlight? That is right, but don't forget angle values are represented as cosine values and an angle of 0 is represented as the cosine value of 1.0 while an angle of 90 degrees is represented as the cosine value of 0.0 as you can see here:

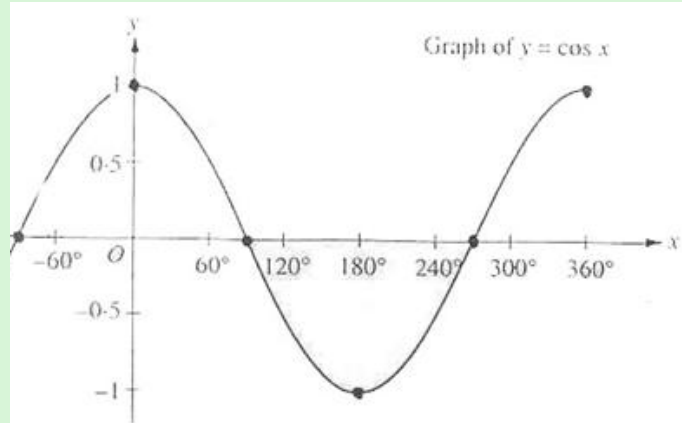

You can now see that the closer the cosine value is to 1.0 the smaller its angle. Now it makes sense why `theta` needs to be larger than the cutoff value. The cutoff value is currently set at the cosine of 12.5 which is equal to 0.9978 so a cosine `theta` value between 0.9979 and 1.0 would result in the fragment being lit as inside the spotlight.

Running the application results in a spotlight that only lights the fragments that are directly inside the cone of the spotlight. It'll look something like this:

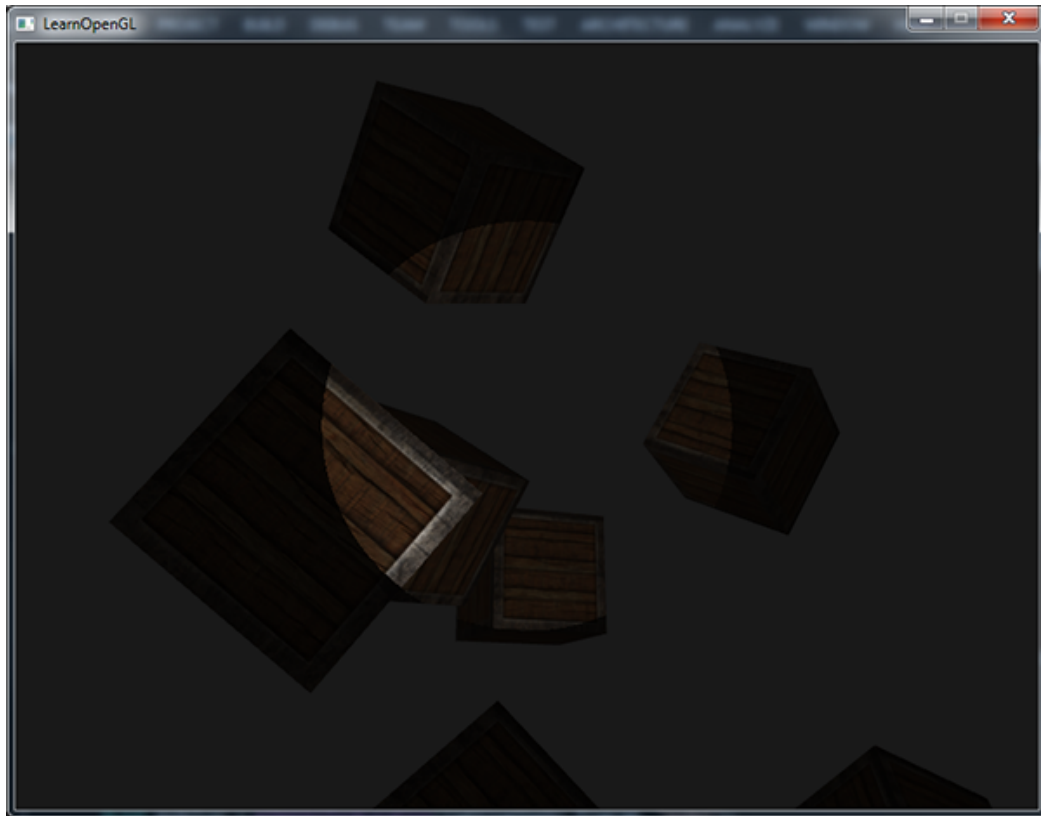

You can find the full source code [here](#) and the fragment shader's source code [here](#).

It still looks a bit fake though, mostly because the spotlight has hard edges. Wherever a fragment reaches the edge of the spotlight's cone it is shut down completely instead of with a nice smooth fade. A realistic spotlight would reduce the light gradually around its edges.

16.6 Smooth/Soft edges

To create the effect of a smoothly-edged spotlight we want to simulate a spotlight having an **inner** and an **outer** cone. We can set the inner cone as the cone defined in the previous section, but we also want an outer cone that gradually dims the light from the inner to the edges of the outer cone.

To create an outer cone we simply define another cosine value that represents the angle between the spotlight's direction vector and the outer cone's vector (equal to its radius). Then, if a fragment is between the inner and the outer cone it should calculate an intensity value between 0.0 and 1.0. If the fragment is inside the inner cone its intensity is equal to 1.0 and 0.0 if the fragment is outside the outer cone.

We can calculate such a value using the following formula:

$$I = \frac{\theta - \gamma}{\varepsilon} \quad (16.2)$$

Here ε (epsilon) is the cosine difference between the inner (ϕ) and the outer cone (γ) ($\varepsilon = \phi - \gamma$). The resulting I value is then the intensity of the spotlight at the current fragment.

It is a bit hard to visualize how this formula actually works so let's try it out with a few sample values:

θ	θ in degrees	ϕ (inner cut-off)	ϕ in degrees	γ (outer cut-off)	γ in degrees	ϵ	I
0.87	30	0.91	25	0.82	35	$0.91 - 0.82 = 0.09$	$0.87 - 0.82 / 0.09 = 0.56$
0.9	26	0.91	25	0.82	35	$0.91 - 0.82 = 0.09$	$0.9 - 0.82 / 0.09 = 0.89$
0.97	14	0.91	25	0.82	35	$0.91 - 0.82 = 0.09$	$0.97 - 0.82 / 0.09 = 1.67$
0.97	14	0.91	25	0.82	35	$0.91 - 0.82 = 0.09$	$0.97 - 0.82 / 0.09 = 1.67$
0.83	34	0.91	25	0.82	35	$0.91 - 0.82 = 0.09$	$0.83 - 0.82 / 0.09 = 0.11$
0.64	50	0.91	25	0.82	35	$0.91 - 0.82 = 0.09$	$0.64 - 0.82 / 0.09 = -2.0$
0.966	15	0.9978	12.5	0.953	17.5	$0.966 - 0.953 = 0.013$	$0.966 - 0.953 / 0.013 = 0.29$

As you can see we're basically interpolating between the outer cosine and the inner cosine based on the θ value. If you still don't really see what's going on, don't worry, you can simply take the formula for granted and return here when you're much older and wiser.

Since we now have an intensity value that is either negative when outside the spotlight, higher than 1.0 when inside the inner cone and somewhere in between around the edges. If we properly clamp the values we don't need an `if-else` in the fragment shader anymore and we can simply multiply the light components with the calculated intensity value:

```
float theta    = dot(lightDir, normalize(-light.direction));
float epsilon = light.cutOff - light.outerCutOff;
float intensity = clamp((theta - light.outerCutOff) / epsilon, 0.0, 1.0);
...
// We'll leave ambient unaffected so we always have a little light.
diffuse *= intensity;
specular *= intensity;
...
```

Note that we use the `clamp` function that `clamps` its first argument between the values 0.0 and 1.0. This makes sure the intensity values won't end up outside the `[0, 1]` interval.

Make sure you add the `outerCutOff` value to the `Light` struct and set its uniform value in the application. For the following image an inner cutoff angle of 12.5f and an outer cutoff angle of 17.5f was used:

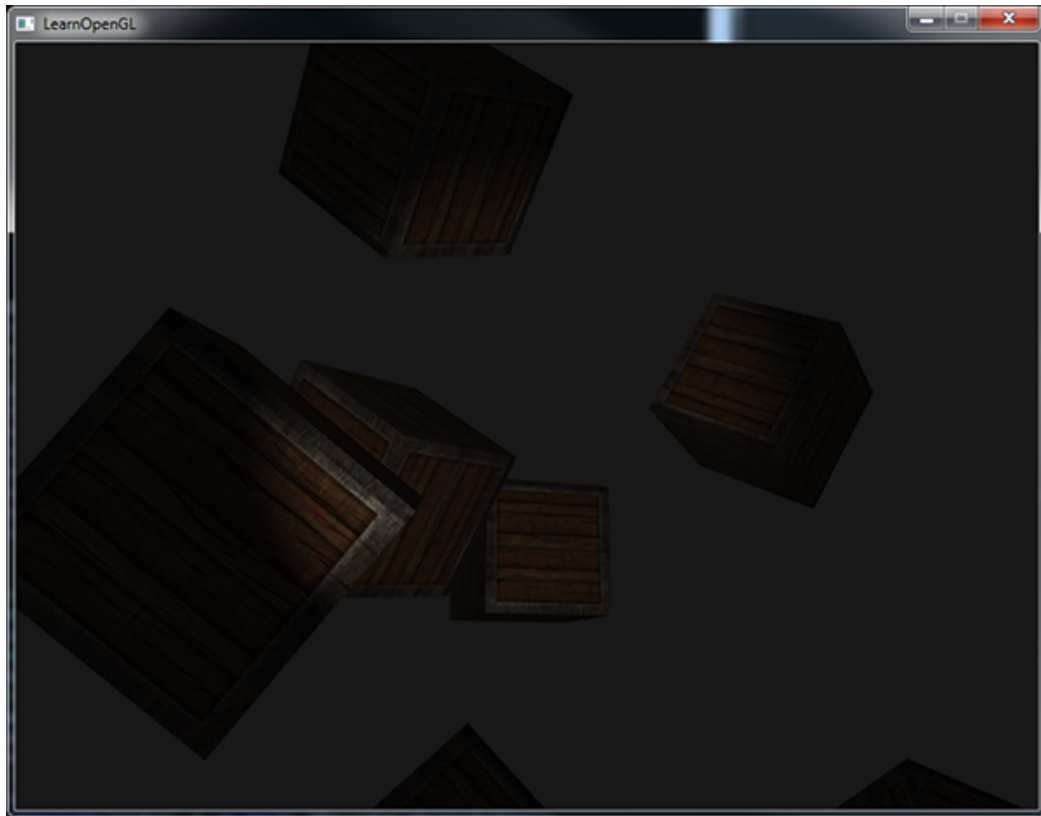

Ahhh, that's much better. Play around with the inner and outer cutoff angles and try to create a spotlight that better suits your needs. You can find the source code of the application [here](#) and the fragment's source code [here](#).

Such a flashlight/spotlight type of lamp is perfect for horror games and combined with directional and point lights the environment will really start to light up. In the [next](#) tutorial we'll combine all the lights and tricks we've discussed so far.

16.7 Exercises

- Try experimenting with all the different light types and their fragment shaders. Try inverting some vectors and/or using $<$ instead of $>$. Try to explain the different visual outcomes.



17. Multiple lights

In the previous tutorials we learned quite a lot about lighting in OpenGL. We learned about Phong shading, materials, lighting maps and different types of light casters. In this tutorial we're going to combine all the previously obtained knowledge by creating a fully lit scene with 6 active light sources. We are going to simulate a sun-like light as a directional light source, 4 point lights scattered throughout the scene and we'll be adding a flashlight as well.

To use more than one light source in the scene we want to encapsulate the lighting calculations into GLSL **functions**. The reason for that is that the code quickly gets nasty when we want to do lighting computations with multiple lights with each light type requiring different computations. If we were to do all these calculations in the `main` function only, the code quickly becomes difficult to understand.

Functions in GLSL are just like C-functions. We have a function name, a return type and we'd have to declare a prototype at the top of the code file if the function hasn't been declared before the main function yet. We'll create a different function for each of the light types: directional lights, point lights and spotlights.

When using multiple lights in a scene the approach is usually as follows: we have a single color vector that represents the fragment's output color. For each light, the light's contribution color of the fragment is added to the fragment's output color vector. So each light in the scene will calculate its individual impact on the aforementioned fragment and contribute to the final output color. A general structure would look something like this:

```
out vec4 color;

void main()
{
    // define an output color value
    vec3 output;
```

```
// add the directional light's contribution to the output
output += someFunctionToCalculateDirectionalLight();
// Do the same for all point lights
for(int i = 0; i < nr_of_point_lights; i++)
    output += someFunctionToCalculatePointLight();
// And add others lights as well (like spotlights)
output += someFunctionToCalculateSpotLight();

color = vec4(output, 1.0);
}
```

The actual code will likely differ per implementation, but the general structure remains the same. We define several functions that calculate the impact per light source and add its resulting color to an output color vector. If for example two light sources are close to the fragment, their combined contribution would result in a more brightly lit fragment than the fragment being lit by a single light source.

17.1 Directional light

What we want to do is define a function in the fragment shader that calculates the contribution a directional light has on the corresponding fragment: a function that takes a few parameters and returns the calculated directional lighting color.

First we need to set the required variables that we minimally need for a directional light source. We can store the variables in a struct called `DirLight` and define it as a uniform. The required variables should be familiar from the [previous](#) tutorial:

```
struct DirLight {
    vec3 direction;

    vec3 ambient;
    vec3 diffuse;
    vec3 specular;
};
uniform DirLight dirLight;
```

We can then pass the `dirLight` uniform to a function with the following prototype:

```
vec3 CalcDirLight(DirLight light, vec3 normal, vec3 viewDir);
```

Just like C and C++ if we want to call a function (in this case inside the `main` function) the function should be defined somewhere before the caller's line number. In this case we'd prefer to define the functions below the `main` function so this requirement doesn't hold. Therefore we declare the function's prototypes somewhere above the `main` function, just like we would in C.

You can see that the function requires a `DirLight` struct and two other vectors required for its computation. If you successfully completed the previous tutorial then the content of this function should come as no surprise:

```

vec3 CalcDirLight(DirLight light, vec3 normal, vec3 viewDir)
{
    vec3 lightDir = normalize(-light.direction);
    // Diffuse shading
    float diff = max(dot(normal, lightDir), 0.0);
    // Specular shading
    vec3 reflectDir = reflect(-lightDir, normal);
    float spec = pow(max(dot(viewDir, reflectDir), 0.0), material.shininess);
    // Combine results
    vec3 ambient = light.ambient * vec3(texture(material.diffuse, TexCoords));
    vec3 diffuse = light.diffuse * diff * vec3(texture(material.diffuse, TexCoords));
    vec3 specular = light.specular * spec * vec3(texture(material.specular, TexCoords));
    return (ambient + diffuse + specular);
}

```

We basically copied the code from the previous tutorial and used the vectors given as function arguments to calculate the directional light's contribution vector. The resulting ambient, diffuse and specular contributions are then returned as a single color vector.

17.2 Point light

Just like with directional lights we also want to define a function that calculates the contribution a point light has on the given fragment, including its attenuation. Just like directional lights we want to define a struct that specifies all the variables required for a point light:

```

struct PointLight {
    vec3 position;

    float constant;
    float linear;
    float quadratic;

    vec3 ambient;
    vec3 diffuse;
    vec3 specular;
};

#define NR_POINT_LIGHTS 4
uniform PointLight pointLights[NR_POINT_LIGHTS];

```

As you can see we used a pre-processor directive in GLSL to define the number of point lights we want to have in our scene. We then use this `NR_POINT_LIGHTS` constant to create an array of `PointLight` structs. Arrays in GLSL are just like C arrays and can be created by the use of two square brackets. Right now we have 4 `PointLight` structs to fill with data.

We could also simply define **one** large struct (instead of different structs per light type) that contains all the necessary variables for **all** the different light types and use that struct for each function, and simply ignore the variables we don't need. However, I personally find the current approach more intuitive and aside from a few extra lines of code it could save up some memory since not all light types need all variables.

The prototype of the point light's function is as follows:

```
vec3 CalcPointLight(PointLight light, vec3 normal, vec3 fragPos, vec3
viewDir);
```

The function takes all the data it needs as its arguments and returns a `vec3` that represents the color contribution that this specific point light has on the fragment. Again, some intelligent copy-and-pasting results in the following function:

```
// Calculates the color when using a point light.
vec3 CalcPointLight(PointLight light, vec3 normal, vec3 fragPos, vec3
viewDir)
{
    vec3 lightDir = normalize(light.position - fragPos);
    // Diffuse shading
    float diff = max(dot(normal, lightDir), 0.0);
    // Specular shading
    vec3 reflectDir = reflect(-lightDir, normal);
    float spec = pow(max(dot(viewDir, reflectDir), 0.0), material.shininess
);
    // Attenuation
    float distance = length(light.position - fragPos);
    float attenuation = 1.0f / (light.constant + light.linear * distance +
light.quadratic * (distance * distance));
    // Combine results
    vec3 ambient = light.ambient * vec3(texture(material.diffuse, TexCoords
));
    vec3 diffuse = light.diffuse * diff * vec3(texture(material.diffuse,
TexCoords));
    vec3 specular = light.specular * spec * vec3(texture(material.specular,
TexCoords));
    ambient *= attenuation;
    diffuse *= attenuation;
    specular *= attenuation;
    return (ambient + diffuse + specular);
}
```

Abstracting this functionality away in a function like this has the advantage that we can easily calculate the lighting for multiple point lights without the need for nasty duplicated code. In the `main` function we simply create a loop that iterates over the point light array that calls `CalcPointLight` for each point light.

17.3 Putting it all together

Now that we defined both a function for directional lights and a function for point lights we can put it all together in the `main` function.

```
void main()
{
    // Properties
    vec3 norm = normalize(Normal);
    vec3 viewDir = normalize(viewPos - FragPos);

    // Phase 1: Directional lighting
    vec3 result = CalcDirLight(dirLight, norm, viewDir);
```



```

// Phase 2: Point lights
for(int i = 0; i < NR_POINT_LIGHTS; i++)
    result += CalcPointLight(pointLights[i], norm, FragPos, viewDir);
// Phase 3: Spot light
//result += CalcSpotLight(spotLight, norm, FragPos, viewDir);

color = vec4(result, 1.0);
}

```

Each light type adds its contribution to the resulting output color until all light sources are processed. The resulting color contains the color impact of all the light sources in the scene combined. If you want you could also implement a spotlight and add its effect to the output color as well. We leave the `CalcSpotLight` function as an exercise for the reader.

Setting the uniforms for the directional light struct shouldn't be too unfamiliar, but you might be wondering how we could set the uniform values of the point lights since the point light uniform is now an array of `PointLight` structs. This isn't something we've discussed before.

Luckily for us, it isn't too complicated. To set the uniform of an array of structs works just like setting the uniforms of a single struct, although this time we also have to define the appropriate index when retrieving the uniform's location:

```

glUniform1f(glGetUniformLocation(lightningShader.Program, "pointLights[0].
constant"), 1.0f);

```

Here we index the first `PointLight` struct in the `pointLights` array and retrieve the location of its `constant` variable. This does mean unfortunately that we have to manually set all the uniforms for each of the 4 point lights, which leads up to 28 uniform calls for the point lights alone which is a bit tedious. You could try to abstract a bit away from this by defining a point light class that sets the uniforms for you, but in the end you'd still have to set the all the lights' uniform values this way.

Let's not forget that we also need to define a position vector for each of the point lights so let's spread them up a bit around the scene. We'll define another `glm::vec3` array that contains the pointlights' positions:

```

glm::vec3 pointLightPositions[] = {
    glm::vec3( 0.7f, 0.2f, 2.0f),
    glm::vec3( 2.3f, -3.3f, -4.0f),
    glm::vec3(-4.0f, 2.0f, -12.0f),
    glm::vec3( 0.0f, 0.0f, -3.0f)
};

```

Then index the corresponding `PointLight` struct from the `pointLights` array and set its `position` attribute as one of the positions we just defined. Also be sure to now draw 4 light cubes instead of just 1. Simply create a different model matrix for each of the light objects just like we did with the containers.

If you'd also use a flashlight the result of all the combined lights looks something like this:

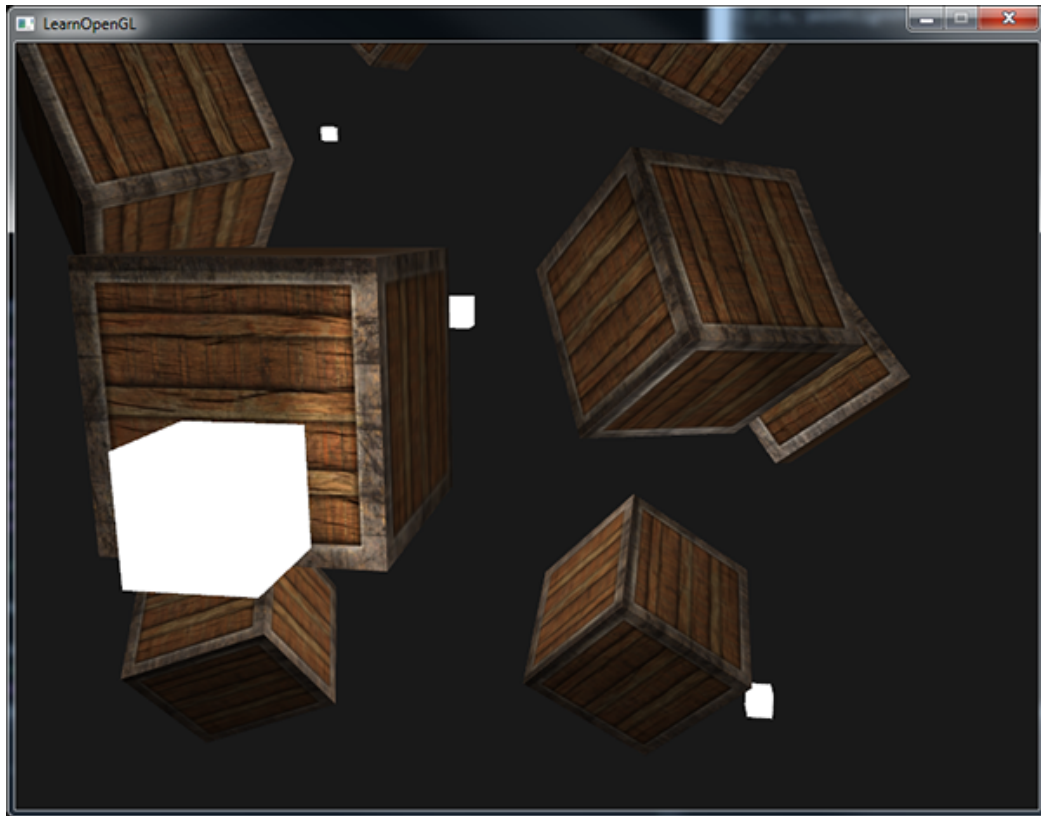

As you can see there appears to be some form of a global light (like a sun) somewhere in the sky, we have 4 lights scattered throughout the scene and a flashlight is visible from the player's perspective. Looks pretty neat doesn't it?

You can find the full source code of the final application [here](#) together with the [vertex](#) and [fragment](#) shader's source code here.

The image shows all the light sources set with the default light properties we've used in all the previous tutorials, but if you'd play around with these values you can get pretty interesting results. Artists and level editors generally tweak all these lighting variables in a large editor to make sure the lighting matches the environment. Using the simple lighted environment we just created you can create some interesting visuals by simply tweaking the lights their attributes:

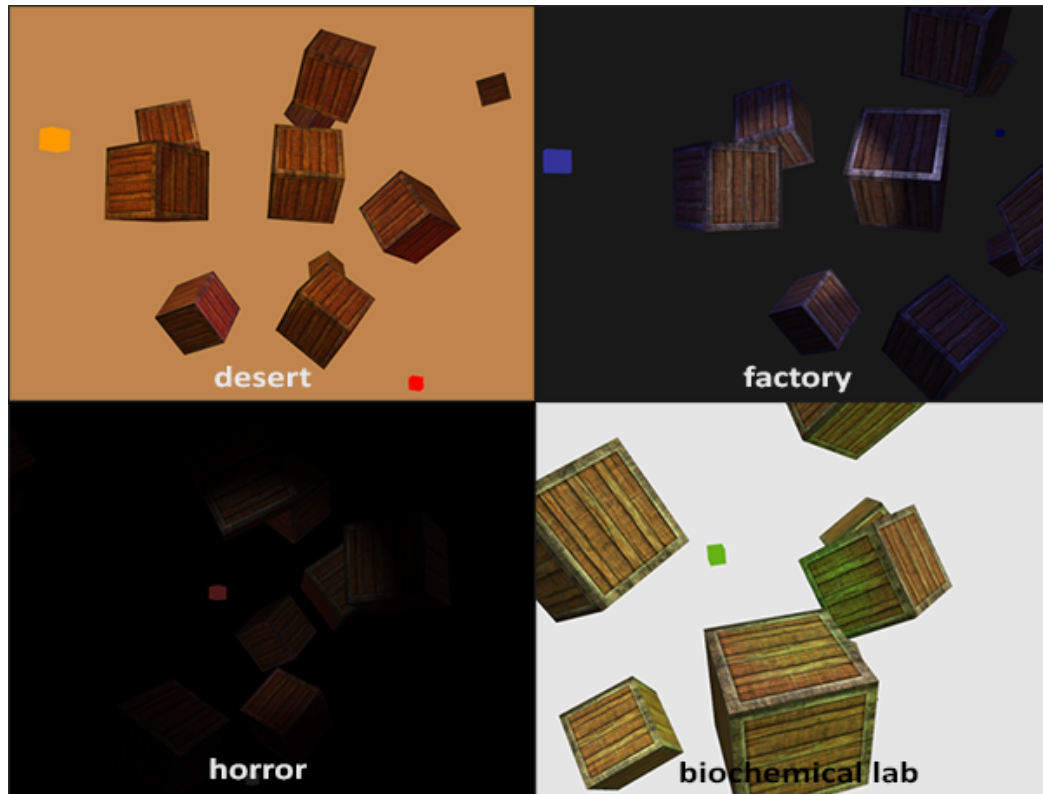

We also changed the clear color to better reflect the lighting. You can see that by simply adjusting some of the lighting parameters you can create completely different atmospheres.

By now you should have a pretty good understanding of lighting in OpenGL. With the knowledge so far we can already create interesting and visually rich environments and atmospheres. Try playing around with all the different values to create your own atmospheres.

17.4 Exercises

- Create a struct for a spotlight, implement the `CalcSpotLight(...)` function and set the appropriate uniform values in your application: [solution](#).
- Can you (sort of) re-create the different atmospheres of the last image by tweaking the light's attribute values? [solution](#).

A futuristic cityscape with a flying vehicle in the foreground. The vehicle is dark with blue glowing lights and is flying towards the left. The city is composed of many tall, thin buildings, some with glowing windows, and the sky is a hazy blue.

18. Review

Congratulations on making it this far! I'm not sure if you noticed, but over all the lighting tutorials we basically learned nothing new about OpenGL itself except a few minor items like accessing uniform arrays. All of the tutorials so far were all about manipulating shaders using techniques and formulas to achieve realistic lighting results. This again shows you the power of shaders. Shaders are extremely flexible and you witnessed firsthand that with just a few 3D vectors and some configurable variables we were able to create amazing graphics with just that!

The last few tutorials you learned about colors, the Phong lighting model (that includes ambient, diffuse and specular lighting), object materials, configurable light properties, diffuse and specular maps, different types of lights and how to combine all the knowledge into a single application. Be sure to experiment with different lights, material colors, light properties and try to create your own environments with the help of a little bit of creativity.

In the next tutorials we'll be adding more advanced shapes to our scene that look really well in the lighting models we've discussed.

18.1 Glossary

- **Color vector:** a vector portraying most of the real world colors via a combination of red, green and blue components (abbreviated to RGB). The color of an object is actually the reflected color components that an object did not absorb.
- **Phong lighting model:** a model for approximating real-world lighting by computing an ambient, diffuse and specular component.
- **Ambient lighting:** approximation of global illumination by giving each object a small brightness so that objects aren't completely dark if not lit.
- **Diffuse shading:** lighting that gets stronger the more a vertex/fragment is aligned to a light source. Makes use of normal vectors to calculate the angles.
- **Normal vector:** a (unit) vector that is perpendicular to a surface.

- **Normal matrix:** a 3x3 matrix that is the model (or model-view) matrix without translation. It is also modified in such a way (inverse-transpose) that it keeps normal vectors facing in the correct direction when applying non-uniform scaling. Otherwise normal vectors get distorted when using non-uniform scaling.
- **Specular lighting:** sets a specular highlight the closer the viewer is looking at the reflection of a light source on a surface. Based on the viewer's direction, the light's direction and a shininess value that sets the amount of scattering of the highlight.
- **Phong shading:** the Phong lighting model applied in the fragment shader.
- **Gouraud shading:** the Phong lighting model applied in the vertex shader. Produces noticeable artifacts when using a small number of vertices. Gains efficiency for loss of visual quality.
- **GLSL struct:** a C-like struct that acts as a container for shader variables. Mostly used for organizing input/output/uniforms.
- **Material:** the ambient, diffuse and specular color an object reflects. These set the colors an object has.
- **Light (properties):** the ambient, diffuse and specular intensity of a light. These can take any color value and define at what color/intensity a light source shines for each specific Phong component.
- **Diffuse map:** a texture image that sets the diffuse color per fragment.
- **Specular map:** a texture map that sets the specular intensity/color per fragment. Allows for specular highlights only on certain areas of an object.
- **Directional light:** a light source with only a direction. It is modeled to be at an infinite distance which has the effect that all its light rays seem parallel and its direction vector thus stays the same over the entire scene.
- **Point light:** a light source with a location in a scene with light that fades out over distance.
- **Attenuation:** the process of light reducing its intensity over distance, used in point lights and spotlights.
- **Spotlight:** a light source that is defined by a cone in one specific direction.
- **Flashlight:** a spotlight positioned from the viewer's perspective.
- **GLSL uniform array:** an array of uniform values. Work just like a C-array, except that they can't be dynamically allocated.

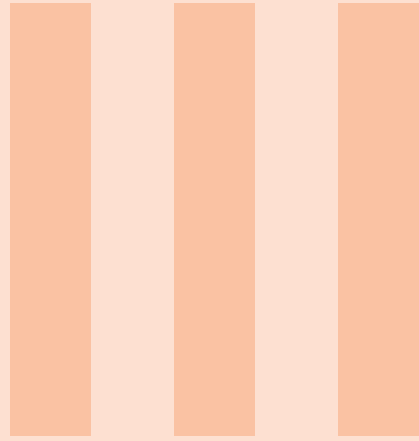

Model Loading

19	Assimp	185
20	Mesh	189
21	Model	194

A futuristic cityscape with a flying vehicle in the foreground. The vehicle is dark with blue glowing lights and is flying towards the left. The city in the background is dense with tall, thin buildings and a hazy atmosphere.

19. Assimp

In all the scenes so far we've been extensively abusing our little container friend in many ways, but over time even our best friends could get a little boring. In practical graphics applications there are usually lots of complicated and interesting models that are much prettier to look at than a static container. However, unlike the container object, we can't really manually define all the vertices, normals and texture coordinates of complicated shapes like houses, vehicles or human-like characters. What we want instead is to *import* these models into the application; models that were carefully designed by 3D artists in tools like [Blender](#), [3DS Max](#) or [Maya](#).

These so called **3D modeling tools** allow artists to create complicated shapes and apply textures to them via a process called **uv-mapping**. The tools then automatically generate all the vertex coordinates, vertex normals and texture coordinates while exporting them to a model file format. This way, artists have an extensive toolkit to create high quality models without having to care too much about the technical details. All the technical aspects are hidden in the exported model file. We, as graphics programmers, **do** have to care about these technical details though.

It is thus our job to parse these exported model files and extract all the relevant information so we can store them in a format that OpenGL understands. A common issue is however that there are dozens of different file formats where each exports the model data in its own unique way. Model formats like the [Wavefront .obj](#) only contains model data with minor material information like model colors and diffuse/specular maps, while model formats like the XML-based [Collada file format](#) are extremely extensive and contain models, lights, many types of materials, animation data, cameras, complete scene information and much more. The wavefront object format is generally considered to be an easy-to-parse model format. It is recommended to visit the Wavefront's wiki page at least once to see how such a file format's data is structured. This should give you a basic perception of how model file formats are generally structured.

All by all, there are many different file formats where a common general structure between them usually does not exist. So if we want to import a model from these file formats we'd have to

write an importer ourselves for each of the file formats we want to import. Luckily for us, there just happens to be a library for this.

19.1 A model loading library

A very popular model importing library out there is called [Assimp](#) that stands for *Open Asset Import Library*. Assimp is able to import dozens of different model file formats (and export to some as well) by loading all the model's data into Assimp's generalized data structures. As soon as Assimp has loaded the model, we can retrieve all the data we need from Assimp's data structures. Because the data structure of Assimp stays the same, regardless of the type of file format we imported, it abstracts us from all the different file formats out there.

When importing a model via Assimp it loads the entire model into a *scene* object that contains all the data of the imported model/scene. Assimp then has a collection of nodes where each node contains indices to data stored in the scene object where each node can have any number of children. A (simplistic) model of Assimp's structure is shown below:

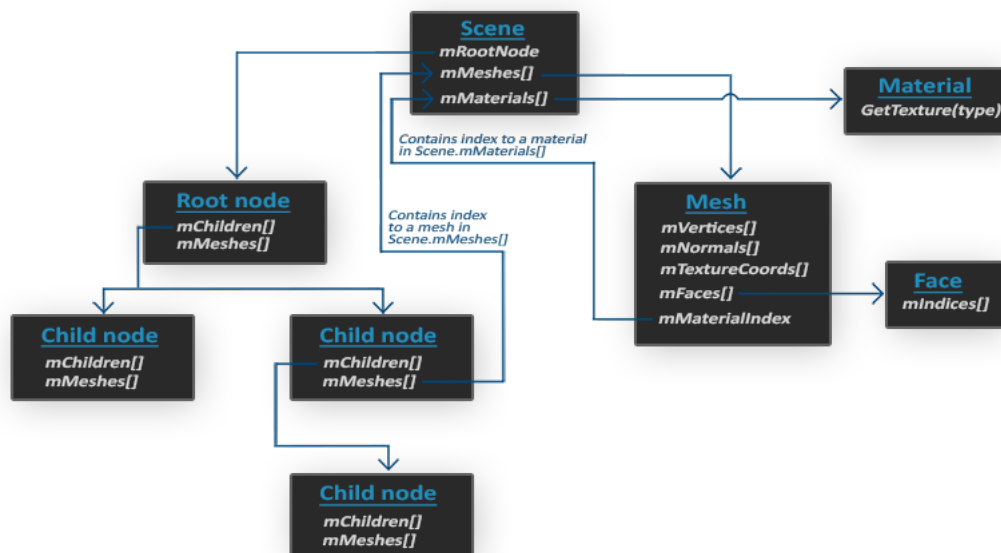

- All the data of the scene/model is contained in the Scene object like all the materials and the meshes. It also contains a reference to the root node of the scene.
- The Root node of the scene may contain children nodes (like all other nodes) and could have a set of indices that point to mesh data in the scene object's `mMeshes` array. The root node's `mMeshes` array contains the actual Mesh objects, the values in the `mMeshes` array of a node are only indices for the scene's meshes array.
- A Mesh object itself contains all the relevant data required for rendering, think of vertex positions, normal vectors, texture coordinates, faces and the material of the object.
- A mesh contains several faces. A Face represents a render primitive of the object (triangles, squares, points). A face contains the indices of the vertices that form a primitive. Because the vertices and the indices are separated, this makes it easy for us to render via an index buffer (see [Hello Triangle](#)).
- Finally a mesh also contains a Material object that hosts several functions to retrieve the material properties of an object. Think of colors and/or texture maps (like diffuse and specular

maps).

So what we want to do is first load an object into a Scene object, recursively retrieve the corresponding Mesh objects from each of the nodes (we recursively search each node's children) and process each Mesh object to retrieve the vertex data, indices and its material properties. The result is then a collection of mesh data that we want to contain in a single Model object.

Mesh

When modelling objects in modelling toolkits, artists generally do not create an entire model out of a single shape. Usually each model has several sub-models/shapes that it consists of. Each of those single shapes that a model is composed of is called a mesh. Think of a human-like character: artists usually model the head, limbs, clothes, weapons all as separate components and the combined result of all these meshes represents the final model. A single mesh is the minimal representation of what we need to draw an object in OpenGL (vertex data, indices and material properties). A model (usually) consists of several meshes.

In the [next](#) tutorials we'll create our own Model and Mesh class that load and store the imported models using the structure we've just described. If we then want to draw a model we do not render the model as a whole but we render all of the individual meshes that the model is composed of. However, before we can start importing models we first need to actually include Assimp in our project.

19.2 Building Assimp

You can download Assimp from their [download](#) page and choose the corresponding version. As of this writing the newest Assimp version used was version 3.1.1. It is advised to compile the libraries by yourself, since their pre-compiled libraries aren't working on most systems. Review the [Creating a window](#) tutorial if you forgot how to compile a library by yourself via CMake.

A few issues came up though while building Assimp so I'll note them down here with their solutions in case any of you get the same errors:

- CMake continually gave errors while retrieving the configuration list about DirectX libraries missing, messages like:

```
Could not locate DirectX
CMake Error at cmake-modules/FindPkgMacros.cmake:110 (message):
Required library DirectX not found! Install the library (including dev
packages)
and try again. If the library is already installed, set the missing
variables
manually in cmake.
```

The solution here is to install the DirectX SDK in case you haven't installed this before. You can download the SDK from [here](#).

- While installing the DirectX SDK a possible error code of s1023 could pop up. In that case you first want to de-install the C++ Redistributable package(s) before installing the SDK as explained [here](#).
- Once the configuration is completed you can generate a solution file, open it and compile the libraries (either as a release version or a debug version, whatever floats your boat).

- The default configuration builds Assimp as a dynamic library so we need to include the resulting DLL named `assimp.dll` alongside the application's binaries. You can simply copy the DLL to the same folder where your application's executable is located.
- After compilation of Assimp the resulting library and DLL file are located in the `code/Debug` or `code/Release` folder.
- Then simply move the lib and DLL to their appropriate locations, link them from your solution and be sure not to forget to copy Assimp's headers to your `include` directory as well (the header files are found in the `include` folder in the files downloaded from Assimp). If you still received any unreported error, feel free to ask for help in the comments below.

If you want Assimp to use multi-threading for faster performance you could compile Assimp with Boost. You can find the full installation instructions at their [installation page](#).

By now you should have compiled Assimp and linked it to your application. Next step: [importing](#) fancy 3D stuff!



20. Mesh

Using Assimp we can load many different models into the application, but once loaded they're all stored in Assimp's data structures. What we eventually want is transform that data to a format that OpenGL understands so that we can render the objects. We learned from the previous tutorial that a mesh represents a single drawable entity so let's start by defining a mesh class of our own.

Let's review a bit of what we've learned so far to think about what a mesh should minimally have as its data. A mesh should at least need a set of vertices where each vertex contains a position vector, a normal vector and a texture coordinate vector. A mesh should also contain indices for indexed drawing and material data in the form of textures (diffuse/specular maps).

Now that we set the minimal requirements for a mesh class we can define a vertex in OpenGL:

```
struct Vertex {
    glm::vec3 Position;
    glm::vec3 Normal;
    glm::vec2 TexCoords;
};
```

We store each of the required vectors in a struct called `Vertex` that we can use to index each of the vertex attributes. Aside from a `Vertex` struct we also want to organize the texture data in a `Texture` struct:

```
struct Texture {
    GLuint id;
    string type;
};
```

We store the id of the texture and its type e.g. a diffuse texture or a specular texture.

Knowing the actual representation of a vertex and a texture we can start defining the structure

of the mesh class:

```
class Mesh {
public:
    /* Mesh Data */
    vector<Vertex> vertices;
    vector<GLuint> indices;
    vector<Texture> textures;
    /* Functions */
    Mesh(vector<Vertex> vertices, vector<GLuint> indices, vector<
Texture> textures);
    void Draw(Shader shader);
private:
    /* Render data */
    GLuint VAO, VBO, EBO;
    /* Functions */
    void setupMesh();
};
```

As you can see the class isn't too complicated. In the constructor we give the mesh all the necessary data, we initialize the buffers in the `setupMesh` function and finally draw the mesh via the `Draw` function. Note that we give a shader to the `Draw` function; by passing the shader to the mesh we can set several uniforms before drawing (like linking samplers to texture units).

The function content of the constructor is pretty straightforward. We simply set the class's public variables with the constructor's corresponding argument variables. We also call the `setupMesh` function in the constructor:

```
Mesh(vector<Vertex> vertices, vector<GLuint> indices, vector<Texture>
textures)
{
    this->vertices = vertices;
    this->indices = indices;
    this->textures = textures;

    this->setupMesh();
}
```

Nothing special going on here. Let's delve right into the `setupMesh` function now.

20.1 Initialization

Thanks to the constructor we now have large lists of mesh data that we can use for rendering. We do need to setup the appropriate buffers though and specify the vertex shader layout via vertex attribute pointers. By now you should have no trouble with these concepts, but we've spiced it up a bit this time with the introduction of vertex data in structs:

```
void setupMesh()
{
    glGenVertexArrays(1, &this->VAO);
    glGenBuffers(1, &this->VBO);
    glGenBuffers(1, &this->EBO);

    glBindVertexArray(this->VAO);
```

```

glBindBuffer(GL_ARRAY_BUFFER, this->VBO);

glBufferData(GL_ARRAY_BUFFER, this->vertices.size() * sizeof(Vertex),
            &this->vertices[0], GL_STATIC_DRAW);

glBindBuffer(GL_ELEMENT_ARRAY_BUFFER, this->EBO);
glBufferData(GL_ELEMENT_ARRAY_BUFFER, this->indices.size() * sizeof(
GLuint),
            &this->indices[0], GL_STATIC_DRAW);

// Vertex Positions
glEnableVertexAttribArray(0);
glVertexAttribPointer(0, 3, GL_FLOAT, GL_FALSE, sizeof(Vertex),
                    (GLvoid*)0);

// Vertex Normals
glEnableVertexAttribArray(1);
glVertexAttribPointer(1, 3, GL_FLOAT, GL_FALSE, sizeof(Vertex),
                    (GLvoid*)offsetof(Vertex, Normal));

// Vertex Texture Coords
glEnableVertexAttribArray(2);
glVertexAttribPointer(2, 2, GL_FLOAT, GL_FALSE, sizeof(Vertex),
                    (GLvoid*)offsetof(Vertex, TexCoords));

glBindVertexArray(0);
}

```

The code is not much different than what you'd expect, but a few little tricks were used with the help of the `Vertex` struct.

Structs have a great property in C++ that their memory layout is sequential. That is if we were to represent a struct as an array of data it would only contain the struct's variables in sequential order which directly translates to a float (actually byte) array that we want for an array buffer. For example, if we have a filled `Vertex` struct its memory layout would be equal to:

```

Vertex vertex;
vertex.Position = glm::vec3(0.2f, 0.4f, 0.6f);
vertex.Normal = glm::vec3(0.0f, 1.0f, 0.0f);
vertex.TexCoords = glm::vec2(1.0f, 0.0f);
// = [0.2f, 0.4f, 0.6f, 0.0f, 1.0f, 0.0f, 1.0f, 0.0f];

```

Thanks to this useful property we can directly pass a pointer to a large list of `Vertex` structs as the buffer's data and they translate perfectly to what `glBufferData` expects as its argument:

```

glBufferData(GL_ARRAY_BUFFER, this->vertices.size() * sizeof(Vertex),
            &this->vertices[0], GL_STATIC_DRAW);

```

Naturally the `sizeof` operator can also be used on the struct for the appropriate size in bytes. This should be 32 bytes (8 floats * 4 bytes each).

Another great use of structs is a preprocessor directive called `offsetof(s, m)` that takes as its first argument a struct and as its second argument a variable name of the struct. The macro returns the byte offset of that variable from the start of the struct. This is perfect for defining the offset parameter of the `glVertexAttribPointer` function:

```

glVertexAttribPointer(1, 3, GL_FLOAT, GL_FALSE, sizeof(Vertex),

```

```
(GLvoid*)offsetof(Vertex, Normal));
```

The offset is now defined using the `offsetof` macro that, in this case, sets the byte offset of the normal vector equal to the byte offset of the normal vector in the struct which is 3 floats and thus 12 bytes. Note that we also set the stride parameter equal to the size of the `Vertex` struct.

Using a struct like this does not only provide more readable code but also allows us to easily extend the structure. If we want another vertex attribute we can simply add it to the struct and due to its flexible nature, the rendering code won't break.

20.2 Rendering

The last function we need to define for the `Mesh` class to be complete is its `Draw` function. Before actually rendering the mesh though we first want to bind the appropriate textures before calling `glDrawElements`. However, this is actually slightly difficult since we don't know from the start how many (if any) textures the mesh has and what type they might have. So how do we set the texture units and samplers in the shaders?

To solve the issue we're going to assume a certain naming convention: each diffuse texture is named `texture_diffuseN` and each specular texture should be named `texture_specularN` where `N` is any number ranging from 1 to the maximum number of texture samplers allowed. Let's say we have 3 diffuse textures and 2 specular textures for a particular mesh, their texture samplers should then be called:

```
uniform sampler2D texture_diffuse1;
uniform sampler2D texture_diffuse2;
uniform sampler2D texture_diffuse3;
uniform sampler2D texture_specular1;
uniform sampler2D texture_specular2;
```

By this convention we can define as many texture samplers as we want in the shaders and if a mesh actually does contain (so many) textures we know what their names are going to be. By this convention we can process any amount of textures on a single mesh and the developer is free to use as many of those as he wants by simply defining the proper samplers (although defining less would be a bit of a waste of bind and uniform calls).

There are many solutions to problems like this and if you don't like this particular solution it is up to you to get creative and come up with your own solution.

The resulting drawing code then becomes:

```
void Draw(Shader shader)
{
    GLuint diffuseNr = 1;
    GLuint specularNr = 1;
    for(GLuint i = 0; i < this->textures.size(); i++)
    {
        glActiveTexture(GL_TEXTURE0 + i); // Activate proper texture unit
        before binding
        // Retrieve texture number (the N in diffuse_textureN)
```

```

        stringstream ss;
        string number;
        string name = this->textures[i].type;
        if(name == "texture_diffuse")
            ss << diffuseNr++; // Transfer GLuint to stream
        else if(name == "texture_specular")
            ss << specularNr++; // Transfer GLuint to stream
        number = ss.str();

        glUniform1f(glGetUniformLocation(shader.Program, ("material." +
name + number).c_str()), i);
        glBindTexture(GL_TEXTURE_2D, this->textures[i].id);
    }
    glActiveTexture(GL_TEXTURE0);

    // Draw mesh
    glBindVertexArray(this->VAO);
    glDrawElements(GL_TRIANGLES, this->indices.size(), GL_UNSIGNED_INT, 0);
    glBindVertexArray(0);
}

```

It's not the most beautiful code but that is partly to blame to how ugly C++ is when [converting](#) types like ints to strings. We first calculate the N-component per texture type and concatenate it to the texture's type string to get the appropriate uniform name. We then locate the appropriate sampler, give it the location value to correspond with the currently active texture unit and bind the texture. This is also the reason we need the shader in the `Draw` function.

We also added "material." to the resulting uniform name because we usually store the textures in a material struct (this might differ per implementation).

Note that we increment the diffuse and specular counters the moment we transfer them to the `stringstream`. In C++ the increment call: `variable++` returns the variable as is and **then** increments the variable while `++variable` **first** increments the variable and then returns it. In our case we first pass the original counter value to the `stringstream` and **then** increment it for the next round [#TheMoreYouKnow](#).

You can find the full source code of the `Mesh` class [here](#).

The `Mesh` class we just defined is a neat abstraction for many of the topics we've discussed in the early tutorials. In the [next](#) tutorial we'll create a model that acts as a container for several mesh objects and actually implement Assimp's loading interface.



21. Model

Now it is time to get our hands dirty with Assimp and start creating the actual loading and translation code. The goal of this tutorial is to create another class that represents a model in its entirety, that is, a model that contains multiple meshes, possibly with multiple objects. A house, that contains a wooden balcony, a tower and perhaps a swimming pool could still be loaded as a single model. We'll load the model via Assimp and translate it to multiple `Mesh` objects we've created in the [last](#) tutorial.

Without further ado, I present you the class structure of the `Model` class:

```
class Model
{
public:
    /* Functions */
    Model(GLchar* path)
    {
        this->loadModel(path);
    }
    void Draw(Shader shader);
private:
    /* Model Data */
    vector<Mesh> meshes;
    string directory;
    /* Functions */
    void loadModel(string path);
    void processNode(aiNode* node, const aiScene* scene);
    Mesh processMesh(aiMesh* mesh, const aiScene* scene);
    vector<Texture> loadMaterialTextures(aiMaterial* mat, aiTextureType
type,
                                     string typeName);
};
```

The `Model` class contains a vector of `Mesh` objects and requires us to give it a file location

in its constructor. It then loads the file right away via the `loadModel` function that is called in the constructor. The private functions are all designed to process a part of Assimp's import routine and we'll cover them shortly. We also store the directory of the file path that we'll later need when loading textures.

The `Draw` function is nothing special and basically loops over each of the meshes to call their respective `Draw` function:

```
void Draw(Shader shader)
{
    for(GLuint i = 0; i < this->meshes.size(); i++)
        this->meshes[i].Draw(shader);
}
```

21.1 Importing a 3D model into OpenGL

To import a model and translate it to our own structure we first need to include the appropriate headers of Assimp so the compiler won't complain to us:

```
#include <assimp/Importer.hpp>
#include <assimp/scene.h>
#include <assimp/postprocess.h>
```

The first function we're calling is `loadModel` that's directly called from the constructor. Within `loadModel` we use Assimp to load the model into a data structure of Assimp called a scene object. You might remember from the [first](#) tutorial of the model loading series that this is the root object of Assimp's data interface. Once we have the scene object we can access all the data we need from the loaded model.

The great thing about Assimp is that it neatly abstracts from all the technical details of loading all the different file formats and does all this with a single one-liner:

```
Assimp::Importer importer;
const aiScene* scene = importer.ReadFile(path, aiProcess_Triangulate |
    aiProcess_FlipUVs);
```

We first declare an actual `Importer` object from Assimp's namespace and then call its `ReadFile` function. The function expects a file path and as its second argument several `post-processing` options. Aside from simply loading the file, Assimp allows us to specify several options that forces Assimp to do some extra calculations/operations on the imported data. By setting `aiProcess_Triangulate` we tell Assimp that if the model does not (entirely) consist of triangles it should transform all the model's primitive shapes to triangles. The `aiProcess_FlipUVs` flips the texture coordinates on the y-axis where necessary during processing (you might remember from the [Textures](#) tutorial that most images in OpenGL were reversed around the y-axis so this little postprocessing option fixes that for us). A few other useful options are:

- `aiProcess_GenNormals` : actually creates normals for each vertex if the model didn't contain normal vectors.
- `aiProcess_SplitLargeMeshes` : splits large meshes into smaller sub-meshes which is useful if your rendering has a maximum number of vertices allowed and can only process smaller meshes.

- `aiProcess_OptimizeMeshes` : actually does the reverse by trying to join several meshes into one larger mesh, reducing drawing calls for optimization.

Assimp provides a great set of postprocessing instructions and you can find all of them [here](#). Actually loading a model via Assimp is (as you can see) surprisingly easy. The hard work lies in using the returned scene object to translate the loaded data to an array of `Mesh` objects.

The complete `loadModel` function is listed here:

```
void loadModel(string path)
{
    Assimp::Importer import;
    const aiScene* scene = import.ReadFile(path, aiProcess_Triangulate |
    aiProcess_FlipUVs);

    if(!scene || scene->mFlags == AI_SCENE_FLAGS_INCOMPLETE || !scene->
    mRootNode)
    {
        cout << "ERROR::ASSIMP::" << import.GetErrorString() << endl;
        return;
    }
    this->directory = path.substr(0, path.find_last_of('/'));

    this->processNode(scene->mRootNode, scene);
}
```

After we load the model, we check if the scene and the root node of the scene are not null and check one of its flags to see if the returned data is incomplete. If any of these error conditions are met, we report an error via the importer's `GetErrorString` function and return. We also retrieve the directory path of the given file path.

If nothing went wrong we want to process all of the scene's nodes so we pass the first node (root node) to the recursive `processNode` function. Because each node (possibly) contains a set of children we want to first process the node in question, and then continue processing all the node's children and so on. This fits a recursive structure so we'll be defining a recursive function. A recursive function is a function that does some processing and **recursively** calls the same function with different parameters until a certain condition is met. In our case the **exit condition** is met when all nodes have been processed.

As you might remember from Assimp's structure each node contains a set of mesh indices where each index points to a specific mesh located in the scene object. We thus want to retrieve these mesh indices, retrieve each mesh, process each mesh and then do this all again for each of the node's children nodes. The content of the `processNode` function is shown below:

```
void processNode(aiNode* node, const aiScene* scene)
{
    // Process all the node's meshes (if any)
    for(GLuint i = 0; i < node->mNumMeshes; i++)
    {
        aiMesh* mesh = scene->mMeshes[node->mMeshes[i]];
        this->meshes.push_back(this->processMesh(mesh, scene));
    }
    // Then do the same for each of its children
    for(GLuint i = 0; i < node->mNumChildren; i++)
    {
```

```

        this->processNode(node->mChildren[i], scene);
    }
}

```

We first check each of the node's mesh indices and retrieve the corresponding mesh by indexing the scene's `mMeshes` array. The returned mesh is then passed to the `processMesh` function that returns a `Mesh` object that we can store in the `meshes` list/vector.

Once all the meshes have been processed we iterate through all of the node's children and call the same `processNode` function for each of the node's children. Once a node no longer has any children the function stops executing.

A careful reader might've noticed that we could basically forget about processing any of the nodes and simply loop through all of the scene's meshes directly without doing all this complicated stuff with indices. The reason we're doing this is that the initial idea for using nodes like this is that it defines a parent-child relation between meshes. By recursively iterating through these relations we can actually define certain meshes to be parents of other meshes.

A use case for such a system is where you want to translate a car mesh and make sure that all its children (like an engine mesh, a steering wheel mesh and its tire meshes) translate as well; such a system is easily created using parent-child relations.

Right now however we're not using such a system, but it is generally recommended to stick with this approach for whenever you want extra control over your mesh data. These node-like relations are after all defined by the artists who created the models.

The next step is to actually process Assimp's data into the `Mesh` class we created last tutorial.

21.1.1 Assimp to Mesh

Translating an `aiMesh` object to a mesh object of our own is not too difficult. All we need to do is access each of the mesh's relevant properties and store them in our own object. The general structure of the `processMesh` function then becomes:

```

Mesh processMesh(aiMesh* mesh, const aiScene* scene)
{
    vector<Vertex> vertices;
    vector<GLuint> indices;
    vector<Texture> textures;

    for(GLuint i = 0; i < mesh->mNumVertices; i++)
    {
        Vertex vertex;
        // Process vertex positions, normals and texture coordinates
        ...
        vertices.push_back(vertex);
    }
    // Process indices
    ...
    // Process material
    if(mesh->mMaterialIndex >= 0)
    {
        ...
    }
}

```

```

    }

    return Mesh(vertices, indices, textures);
}

```

Processing a mesh basically consists of 3 sections: retrieving all the vertex data, retrieving the mesh's indices and finally retrieving the relevant material data. The processed data is stored in one of the 3 vectors and from those a `Mesh` is created and returned to the function's caller.

Retrieving the vertex data is pretty simple: we define a `Vertex` struct that we add to the `vertices` array after each iteration. We loop for as much vertices there exist within the mesh (retrieved via `mesh->mNumVertices`). Within the iteration we then want to fill this struct with all the relevant data. For vertex positions this is done as follows:

```

glm::vec3 vector;
vector.x = mesh->mVertices[i].x;
vector.y = mesh->mVertices[i].y;
vector.z = mesh->mVertices[i].z;
vertex.Position = vector;

```

Note that we define a placeholder `vec3` for transferring Assimp's data to. We need the placeholder since Assimp maintains its own data types for vector, matrices, strings etc. and they don't convert really well to glm's data types.

Assimp calls their vertex position array `mVertices` which isn't really too intuitive.

The procedure for normals should come as no surprise now:

```

vector.x = mesh->mNormals[i].x;
vector.y = mesh->mNormals[i].y;
vector.z = mesh->mNormals[i].z;
vertex.Normal = vector;

```

Texture coordinates are roughly the same, but Assimp allows a model to have up to 8 different texture coordinates per vertex which we're not going to use so we only care about the first set of texture coordinates. We'll also want to check if the mesh actually contains texture coordinates (which might not be always the case):

```

if(mesh->mTextureCoords[0]) // Does the mesh contain texture coordinates?
{
    glm::vec2 vec;
    vec.x = mesh->mTextureCoords[0][i].x;
    vec.y = mesh->mTextureCoords[0][i].y;
    vertex.TexCoords = vec;
}
else
    vertex.TexCoords = glm::vec2(0.0f, 0.0f);

```

The `vertex` struct is now completely filled with the required vertex attributes and we can push it to the back of the `vertices` vector at the end of the iteration. This process is repeated for each of the mesh's vertices.

21.1.2 Indices

Assimp's interface defined each mesh having an array of faces where each face represents a single primitive, which in our case (due to the `aiProcess_Triangulate` option) are always triangles. A face contains the indices that define which vertices we need to draw in what order for each primitive so if we iterate over all the faces and store all the face's indices in the `indices` vector we're all set:

```
for(GLuint i = 0; i < mesh->mNumFaces; i++)
{
    aiFace face = mesh->mFaces[i];
    for(GLuint j = 0; j < face.mNumIndices; j++)
        indices.push_back(face.mIndices[j]);
}
```

After the outer loop has finished we now have a complete set of vertices and index data for drawing the mesh via `glDrawElements`. However, to finish the discussion and to add some detail to the mesh we want to process the mesh's material as well.

21.1.3 Material

Just like with nodes, a mesh only contains an index to a material object and to retrieve the actual material of a mesh we need to index the scene's `mMaterials` array. The mesh's material index is set in its `mMaterialIndex` property which we can also query to check if the mesh actually contains a material or not:

```
if(mesh->mMaterialIndex >= 0)
{
    aiMaterial* material = scene->mMaterials[mesh->mMaterialIndex];
    vector<Texture> diffuseMaps = this->loadMaterialTextures(material,
        aiTextureType_DIFFUSE, "
texture_diffuse");
    textures.insert(textures.end(), diffuseMaps.begin(), diffuseMaps.end());
;
    vector<Texture> specularMaps = this->loadMaterialTextures(material,
        aiTextureType_SPECULAR, "
texture_specular");
    textures.insert(textures.end(), specularMaps.begin(), specularMaps.end
());
}
```

We first retrieve the `aiMaterial` object from the scene's `mMaterials` array. Then we want to load the mesh's diffuse and/or specular textures. A material object internally stores an array of texture locations for each texture type. The different texture types are all prefixed with `aiTextureType_`. We use a helper function called `loadMaterialTextures` to retrieve the textures from the material. The function returns a vector of `Texture` structs that we then store at the end of the model's `textures` vector.

The `loadMaterialTextures` function iterates over all the texture locations of the given texture type, retrieves the texture's file location and then loads and generates the texture and stores the information in a `Vertex` struct. It looks like this:

```
vector<Texture> loadMaterialTextures(aiMaterial* mat, aiTextureType type,
    string typeName)
{
    vector<Texture> textures;
    for(GLuint i = 0; i < mat->GetTextureCount(type); i++)
    {
        aiString str;
        mat->GetTexture(type, i, &str);
        Texture texture;
        texture.id = TextureFromFile(str.C_Str(), this->directory);
        texture.type = typeName;
        texture.path = str;
        textures.push_back(texture);
    }
    return textures;
}
```

We first check the amount of textures stored in the material via its `GetTextureCount` function that expects one of the texture types we've given. We then retrieve each of the texture's file locations via the `GetTexture` function that stores the result in an `aiString`. We then use another helper function called `TextureFromFile` that loads a texture (with SOIL) for us and returns the texture's ID. You can check the complete code listing at the end for its content if you're not sure how such a function is written.

Note that we make the assumption that texture file paths in model files are local to the actual model object e.g. in the same directory as the location of the model itself. We can then simply concatenate the texture location string and the directory string we retrieved earlier (in the `loadModel` function) to get the complete texture path (that's why the `GetTexture` function also needs the directory string).

Some models found over the internet still use absolute paths for their texture locations which won't work on each machine. In that case you probably want to manually edit the file to use local paths for the textures (if possible).

And that is all there is to importing a model using Assimp. You can find the complete source code of the `Model` class [here](#).

21.2 A large optimization

We're not completely done yet, since there is still a large (but not completely necessary) optimization we want to make. Most scenes re-use several of their textures onto several meshes; think of a house again that has a granite texture for its walls. This texture could also be applied to the floor, its ceilings, the staircase, perhaps a table and maybe even a small well close by. Loading textures is not a cheap operation and in our current implementation a new texture is loaded and generated for each mesh even though the exact same texture has been loaded several times before. This quickly becomes the bottleneck of your model loading implementation.

So we're going to add one small tweak to the model code by storing all of the loaded textures globally and wherever we want to load a texture we first check if it hasn't been loaded already. If so, we take that texture and skip the entire loading routine saving us lots of processing power. To be able to actually compare textures we need to store their path as well:

```

struct Texture {
    GLuint id;
    string type;
    aiString path; // We store the path of the texture to compare with
                  // other textures
};

```

Then we store all the loaded textures in another vector declared at the top of the model's class file as a private variable:

```
vector<Texture> textures_loaded;
```

Then in the `loadMaterialTextures` function we want to compare the texture path with all the textures in the `textures_loaded` vector to see if the current texture path is similar to any of those. If so, we skip the texture loading/generation part and simply use the located texture struct as the mesh's texture. The (updated) function is shown below:

```

vector<Texture> loadMaterialTextures(aiMaterial* mat, aiTextureType type,
string typeName)
{
    vector<Texture> textures;
    for(GLuint i = 0; i < mat->GetTextureCount(type); i++)
    {
        aiString str;
        mat->GetTexture(type, i, &str);
        GLboolean skip = false;
        for(GLuint j = 0; j < textures_loaded.size(); j++)
        {
            if(textures_loaded[j].path == str)
            {
                textures.push_back(textures_loaded[j]);
                skip = true;
                break;
            }
        }
        if(!skip)
        { // If texture hasn't been loaded already, load it
            Texture texture;
            texture.id = TextureFromFile(str.C_Str(), this->directory);
            texture.type = typeName;
            texture.path = str;
            textures.push_back(texture);
            this->textures_loaded.push_back(texture); // Add to loaded
        }
    }
    return textures;
}

```

So now we do not only have an extremely versatile model loading system, but we also have an optimized one that loads objects quite fast.

Some versions of Assimp tend to load models quite slow when using the debug version and/or the debug mode of your IDE so be sure to test it out with release versions as well if you run into slow loading times.

You can find the complete source code of the optimized `Model` class [here](#).

21.3 No more containers!

So let's give our implementation a spin by actually importing a model created by genuine artists, not something done by the creative genius that I am (you got to admit, those containers were probably one of the most beautiful cubical shapes you've seen). Because I don't want to give myself too much credit I'll occasionally allow some other artists to join the ranks and this time we're going to load the original `nanosuit` used by Crytek's game `Crysis`. The model is exported as a `.obj` file together with a `.mtl` file that contains the model's diffuse, specular and normal maps (more about those later). You can download the model [here](#), note that all the textures and the model files should be located in the same directory for the textures to load.

The version you can download from this website is a modified version where each texture file path was modified to a local relative path instead of an absolute path if downloaded from the original source.

Now in the code, declare a `Model` object and pass in the model's file location. The model should then automatically load and (if there were no errors) draw the object in the game loop using its `Draw` function and that is it. No more buffer allocations, attribute pointers and render commands, just a simple one-liner. Then if you create a simple set of shaders where the fragment shader only outputs the object's diffuse texture color the result looks a bit like this:



You can find the complete source code [here](#) together with its `vertex` and `fragment` shader.

We could also get more creative and introduce two point lights to the render equation as we learned from the [Lighting](#) tutorials and together with specular maps get amazing results:



Even I have to admit that this is maybe a bit more fancy than the containers we've used so far. Using Assimp you can load tons of models found over the internet. There are quite a few resource websites that offer free 3D models for you to download in several file formats. Do note that some models still won't load properly, have texture paths that won't work or might simply be exported in a format even Assimp can't read.

21.4 Exercises

- Can you re-create the last scene with the two point lights?: [solution](#), [shaders](#).

IV

Advanced OpenGL

22	Depth testing	205
23	Stencil testing	216
24	Blending	223
25	Face culling	235
26	Framebuffers	240
27	Cubemaps	254
28	Advanced Data	269
29	Advanced GLSL	273
30	Geometry Shader	288
31	Instancing	305
32	Anti Aliasing	317

A futuristic cityscape with a flying vehicle in the foreground. The vehicle is dark with blue lights and is flying towards the left. The city is composed of many tall, thin buildings, some of which are blurred due to a shallow depth of field or motion blur. The sky is a mix of blue and grey, suggesting a hazy or overcast day.

22. Depth testing

In the [coordinate systems](#) tutorial we've rendered a 3D container and made use of a [depth buffer](#) to prevent faces rendering to the front while they're behind other faces. In this tutorial we're going to elaborate a bit more on these [depth values](#) the depth buffer (or z-buffer) is storing and how it actually determines if a fragment is indeed behind other fragments.

The depth-buffer is a buffer that, just like the [color buffer](#) (that stores all the fragment colors: the visual output), stores information per fragment and (usually) has the same width and height as the color buffer. The depth buffer is automatically created by the windowing system and stores its depth values as 16, 24 or 32 bit floats. In most systems you'll see a depth buffer with a precision of 24 bits.

When depth testing is enabled OpenGL tests the depth value of a fragment against the content of the depth buffer. OpenGL performs a depth test and if this test passes, the depth buffer is updated with the new depth value. If the depth test fails, the fragment is discarded.

Depth testing is done in screen space after the fragment shader has run (and after stencil testing has run which we'll discuss in the [next](#) tutorial). The screen space coordinates relate directly to the viewport defined by OpenGL's [glViewport](#) function and can be accessed via GLSL's built-in [gl_FragCoord](#) variable in the fragment shader. The x and y components of [gl_FragCoord](#) represent the fragment's screen-space coordinates (with (0,0) being the bottom-left corner). The [gl_FragCoord](#) also contains a z-component which contains the actual depth value of the fragment. This z value is the value that is compared to the depth buffer's content.

Today most GPUs support a hardware feature called **early depth testing**. Early depth testing allows the depth test to run before the fragment shader runs. Wherever it is clear a fragment is never going to be visible (it is behind other objects) we can prematurely discard the fragment.

Fragment shaders are usually quite expensive so wherever we can avoid running them we should. A restriction on the fragment shader for early depth testing is that you shouldn't write to the fragment's depth value. If a fragment shader would write to its depth value, early depth testing is impossible; OpenGL won't be able to figure out the depth value beforehand.

Depth testing is disabled by default so to enable depth testing we need to enable it with the `GL_DEPTH_TEST` option:

```
glEnable(GL_DEPTH_TEST);
```

Once enabled OpenGL automatically stores fragments their z-values in the depth buffer if they passed the depth test and discards fragments if they failed the depth test accordingly. If you have depth testing enabled you should also clear the depth buffer before each render iteration using the `GL_DEPTH_BUFFER_BIT`, otherwise you're stuck with the written depth values from last render iteration:

```
glClear(GL_COLOR_BUFFER_BIT | GL_DEPTH_BUFFER_BIT);
```

There are certain scenarios imaginable where you want to perform the depth test on all fragments and discard them accordingly, but **not** update the depth buffer. Basically, you're using a **read-only** depth buffer. OpenGL allows us to disable writing to the depth buffer by setting its depth mask to `GL_FALSE`:

```
glDepthMask(GL_FALSE);
```

Note that this only has effect if depth testing is enabled.

22.1 Depth test function

OpenGL allows us to modify the comparison operators it uses for the depth test. This allows us to control when OpenGL should pass or discard fragments and when to update the depth buffer. We can set the comparison operator (or depth function) by calling `glDepthFunc`:

```
glDepthFunc(GL_LESS);
```

The function accepts several comparison operators that are listed in the table below:

Function	Description
GL_ALWAYS	The depth test always passes.
GL_NEVER	The depth test never passes.
GL_LESS	Passes if the fragment's depth value is less than the stored depth value.
GL_EQUAL	Passes if the fragment's depth value is equal to the stored depth value.
GL_LEQUAL	Passes if the fragment's depth value is less than or equal to the stored depth value.
GL_GREATER	Passes if the fragment's depth value is greater than the stored depth value.
GL_NOTEQUAL	Passes if the fragment's depth value is not equal to the stored depth value.
GL_GEQUAL	Passes if the fragment's depth value is greater than or equal to the stored depth value.

By default the depth function `GL_LESS` is used that discards all the fragments that have a depth value higher than or equal to the current depth buffer's value.

Let's show the effect that changing the depth function has on the visual output. We'll use a fresh code setup that displays a basic scene with two textured cubes sitting on a textured floor with no lighting. You can find the source code [here](#) and its shaders [here](#).

Within the source code we changed the depth function to `GL_ALWAYS`:

```
glEnable(GL_DEPTH_TEST);  
glDepthFunc(GL_ALWAYS);
```

This simulates the same behavior we get if we didn't enable depth testing. The depth test simply always passes so the fragments that are drawn last are rendered in front of the fragments that were drawn before, even though they should've been at the front. Since we've drawn the floor plane as last the plane's fragments overwrite each of the container's fragments:

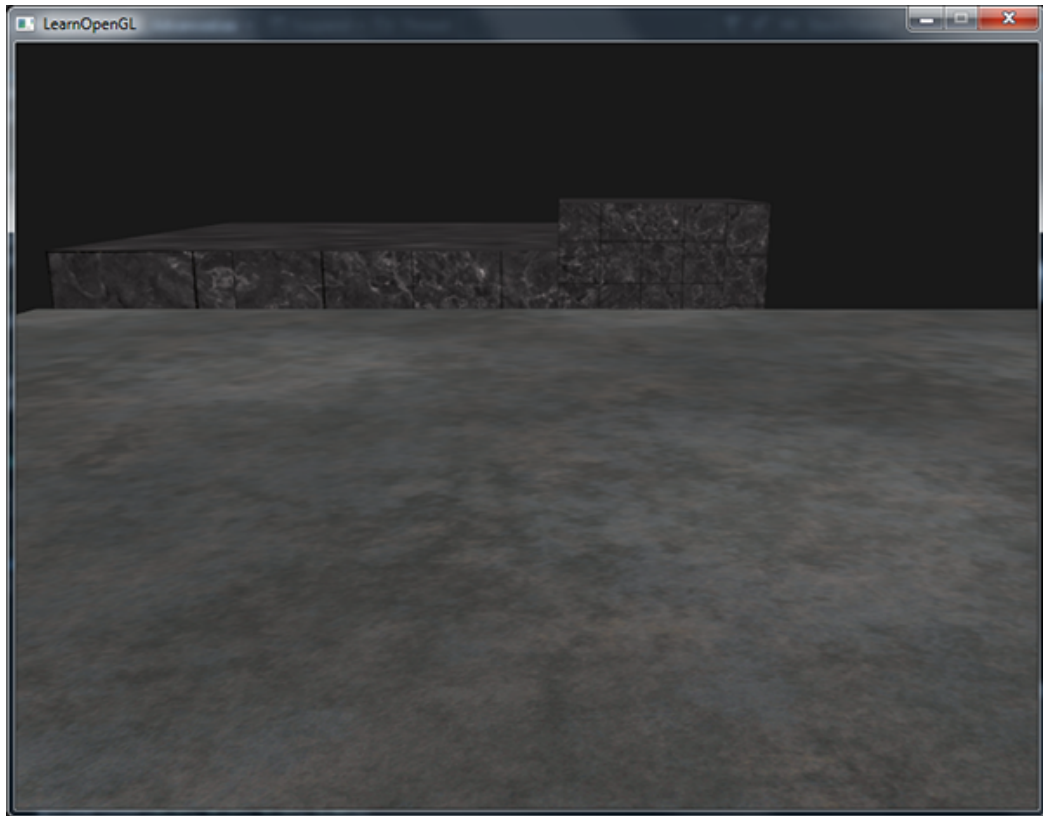

Setting it all back to `GL_LESS` gives us the type of scene we're used to:

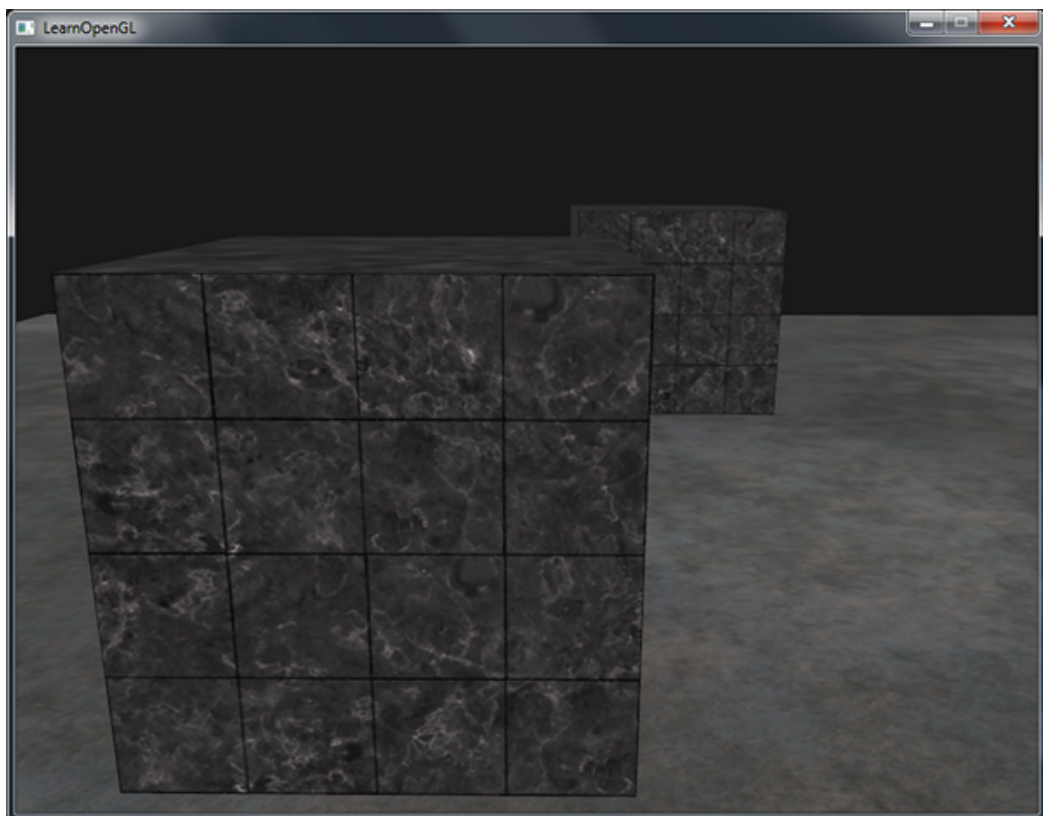

22.2 Depth value precision

The depth buffer contains depth values between 0.0 and 1.0 and it compares its content with z-value of all the objects in the scene as seen from the viewer. These z-values in view space can be any value between the projection frustum's `near` and `far` value. We thus need some way to transform these view-space z-values to the range of $[0, 1]$ and one way is to linearly transform them to the $[0, 1]$ range. The following (linear) equation then transforms the z-value to a depth value between 0.0 and 1.0:

$$F_depth = \frac{z - near}{far - near} \quad (22.1)$$

Here `near` and `far` are the `near` and `far` values we used to provide to the projection matrix to set the visible frustum (see [coordinate Systems](#)). The equation takes a depth value z within the frustum and transforms it to the range $[0, 1]$. The relation between the z-value and its corresponding depth value is presented in the following graph:

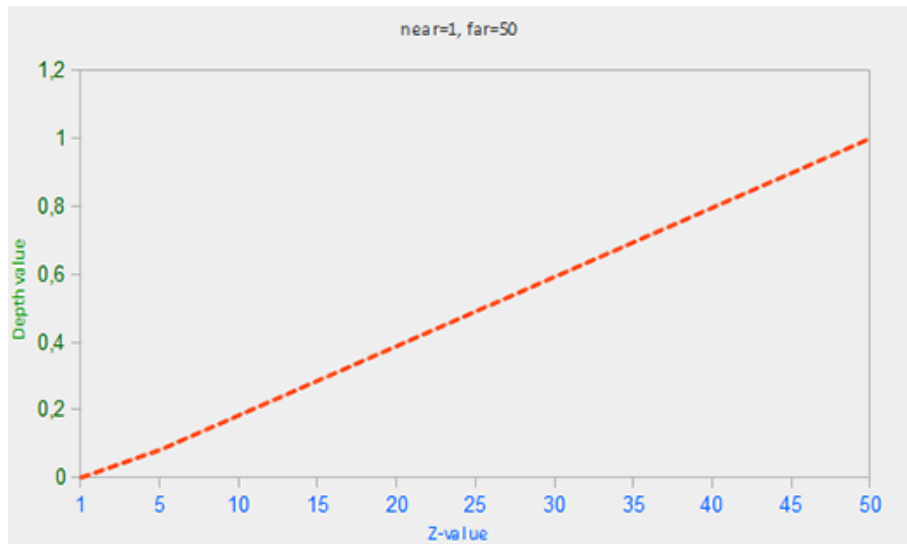

Note that all equations give a depth value close to 0.0 when the object is close by and a depth value close to 1.0 when the object is close to the far plane.

In practice however, a **linear depth buffer** like this is almost never used. For correct projection properties a non-linear depth equation is used that is proportional to $1/z$. What this basically does is give us enormous precision when z is small and much less precision when z is far away. Think about this for a second: do we really want the depth values that are 1000 units away to have the same precision as highly-detailed objects at a distance of 1? The linear equation doesn't take this into account.

Since the non-linear function is proportional to $1/z$, z-values between 1.0 and 2.0 for example would result in depth values between 1.0 and 0.5 which is half of the precision a float provides us, giving us enormous precision at small z-values. Z-values between 50.0 and 100.0 would account for only 2% of the float's precision, this is exactly what we want. Such an equation, that also takes near and far distances into account, is given below:

$$F_depth = \frac{1/z - 1/near}{1/far - 1/near} \quad (22.2)$$

Don't worry if you don't know exactly what is going on with this equation. The important thing to remember is that the values in the depth buffer are not linear in screen-space (they are linear in view-space before the projection matrix is applied). A value of 0.5 in the depth buffer does not mean the object's z-values are halfway in the frustum; the z-value of the vertex is actually quite close to the near plane! You can see the non-linear relation between the z-value and the resulting depth buffer's value in the following graph:

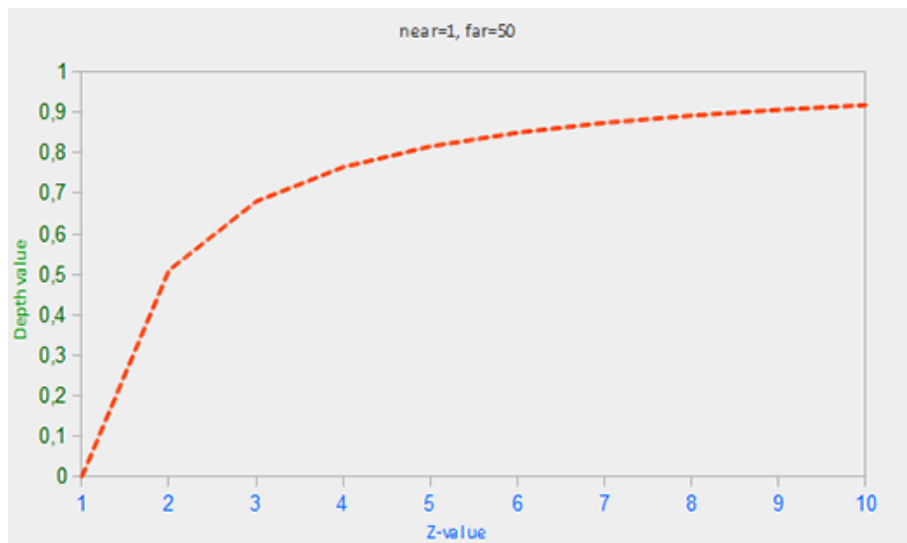

As you can see, the depth values are greatly determined by the small z-values thus giving us enormous depth precision to the objects close by. The equation to transform z-values (from the viewer's perspective) is embedded within the projection matrix so when we transform vertex coordinates from view to clip and then to screen-space the non-linear equation is applied. If you're curious as to what the projection matrix actually does in detail I suggest the following [great article](#)

The effect of this non-linear equation quickly becomes apparent when we try to visualize the depth buffer.

22.3 Visualizing the depth buffer

We know that the z-value of the built-in `gl_FragCoord` vector in the fragment shader contains the depth value of that particular fragment. If we were to output this depth value of the fragment as a color we could display the depth values of all the fragments in the scene. We can do this by returning a color vector based on the fragment's depth value:

```
void main()
{
    color = vec4(vec3(gl_FragCoord.z), 1.0f);
}
```

If you'd then run the same program again you'll probably notice that everything is white, making it look like all of our depth values are 1.0 which is the maximum depth value. So why aren't any of the depth values closer to 0.0 and thus darker?

You might remember from the previous section that the depth values in screen space are non-linear e.g. they have a very high precision for small z-values and a low precision for large z-values. The depth value of the fragment increases rapidly over distance so almost all the vertices have values close to 1.0 . If we were to carefully move really close to objects you might eventually see the colors getting darker, showing that their z-values are becoming smaller:

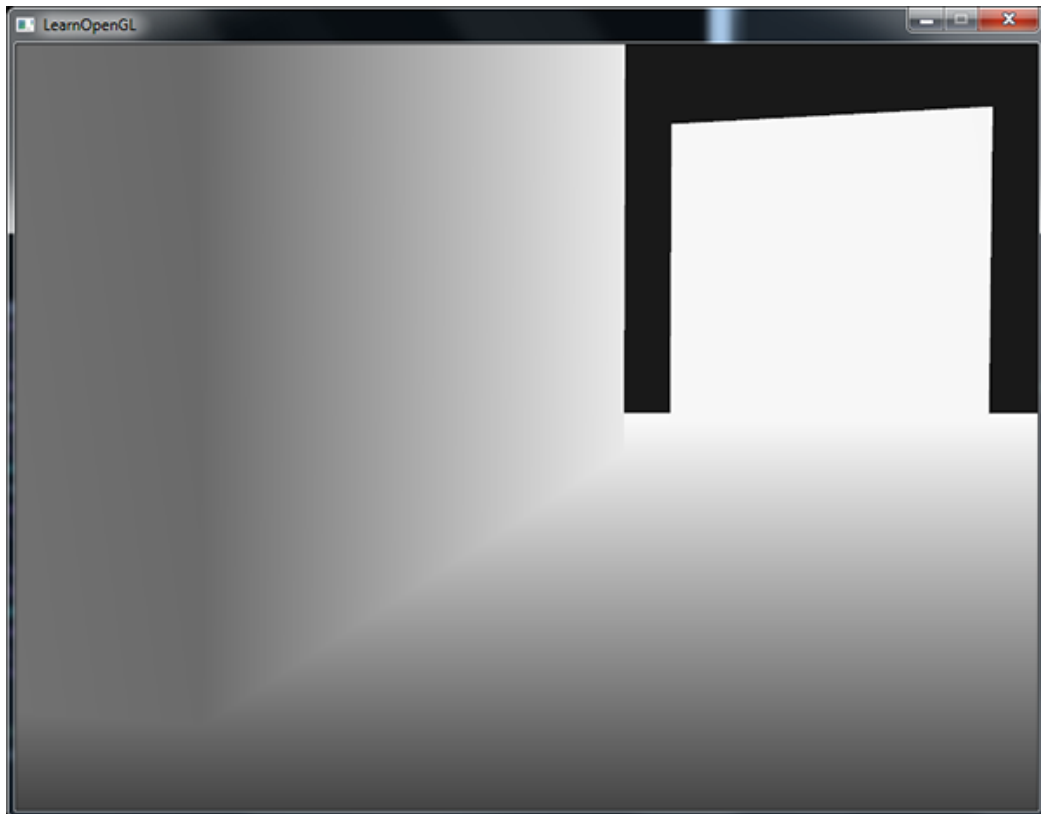

This clearly shows the non-linearity of the depth value. Objects close by have a much larger effect on the depth value than objects far away. Only moving a few inches results in the colors going from dark to completely white.

We can however, transform the non-linear depth values of the fragment back to their linear siblings. To achieve this we basically need to reverse the process of projection for the depth values alone. This means we have to first re-transform the depth values from the range $[0, 1]$ to normalized device coordinates in the range $[-1, 1]$ (clip space). Then we want to reverse the non-linear equation (equation 2) as done in the projection matrix and apply this inversed equation to the resulting depth value. The result is then a linear depth value. Sounds do-able right?

First we want to transform the depth value to NDC which is not too difficult:

```
float z = depth * 2.0 - 1.0;
```

We then take the resulting z value and apply the inverse transformation to retrieve the linear

depth value:

```
float linearDepth = (2.0 * near) / (far + near - z * (far - near));
```

Note that this equation is not precisely the inverse of equation 2. This equation is derived from the projection matrix that again uses equation 2 to non-linearize the depth values. This equation also takes into account that the z-values are supplied in the range $[0, 1]$ instead of $[\text{near}, \text{far}]$. This [math-heavy article](#) explains the projection matrix in enormous detail for the interested reader; it also shows where the equations come from.

This is not the exact equation as derived from the projection matrix; this equation is the result of a division by `far`. The depth values range all the way to the far plane which doesn't fit nicely as a color value between `0.0` and `1.0`. Dividing by `far` maps the depth values to `0.0` and `1.0` which is better suited for demonstration purposes.

The complete fragment shader that transforms the non-linear depth in screen-space to a linear depth value is then as follows:

```
#version 330 core

out vec4 color;

float LinearizeDepth(float depth)
{
    float near = 0.1;
    float far = 100.0;
    float z = depth * 2.0 - 1.0; // Back to NDC
    return (2.0 * near) / (far + near - z * (far - near));
}

void main()
{
    float depth = LinearizeDepth(gl_FragCoord.z);
    color = vec4(vec3(depth), 1.0f);
}
```

If we'd now run the application we get depth values that are actually linear over distance. Try moving around the scene to see the depth values change in a linear fashion.

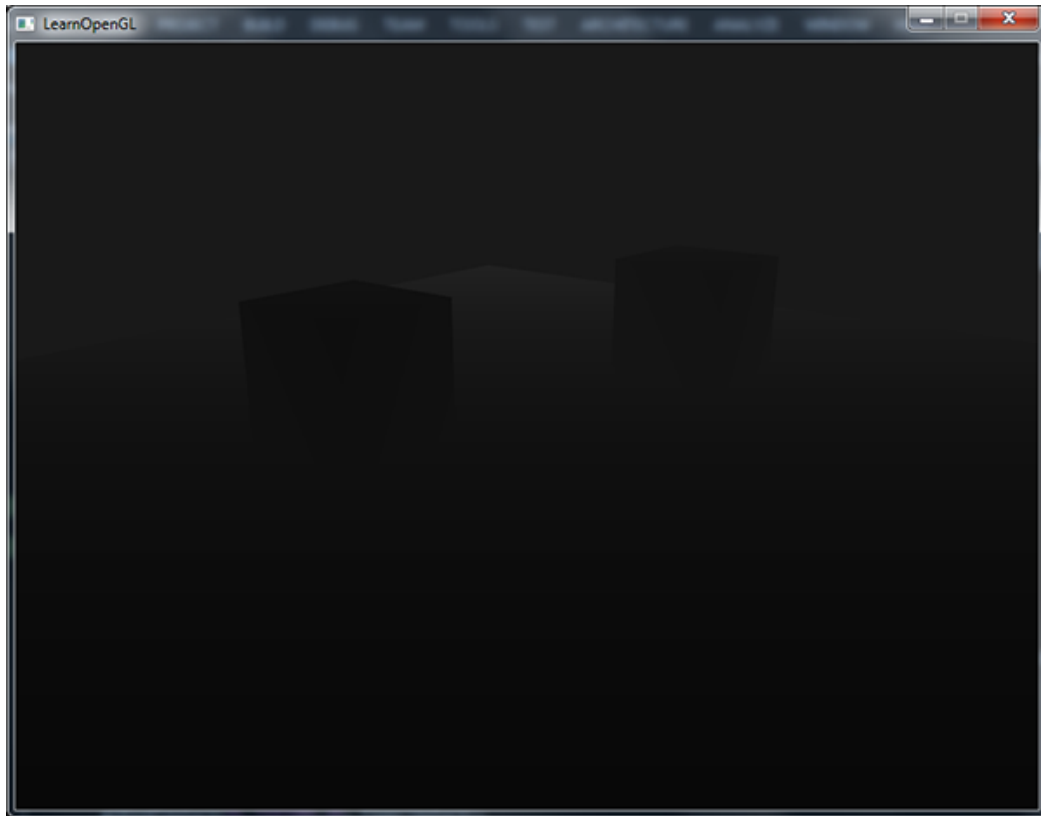

The colors are mostly black because the depth values range linearly from the `near` plane which is `0.1` to the `far` plane which is `100` that is still quite far away from us. The result is that we're relatively close to the near plane and thus get lower (darker) depth values.

22.4 Z-fighting

A common visual artifact might occur when two planes or triangles are so closely aligned to each other that the depth buffer does not have enough precision to figure out which one of the two shapes is in front of the other. The result is that the two shapes continually seem to switch order which causes weird glitchy patterns. This is called *z-fighting*, because it looks like the shapes are fighting over who gets on top.

In the scene we've been using so far there are a few spots where *z-fighting* is quite noticeable. The containers were placed at the exact height that the floor was placed which means the bottom plane of the container is coplanar with the floor plane. The depth values of both planes are then the same so the resulting depth test has no way of figuring out which is the right one.

If you move the camera inside one of the containers the effects are clearly visible, the bottom part of the container is constantly switching between the container's plane and the floor's plane in a zigzag pattern:

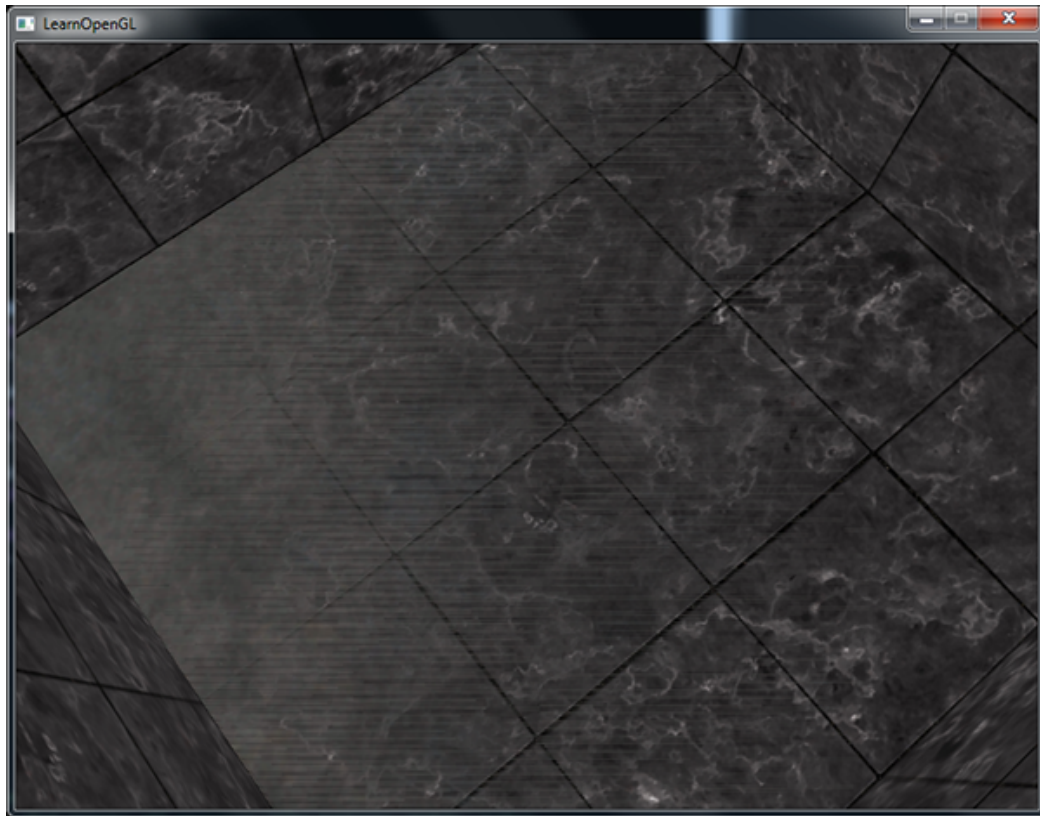

Z-fighting is a common problem with depth buffers and is generally stronger when objects are at a further distance (because the depth buffer has less precision at larger z-values). Z-fighting can't be completely prevented, but there are generally a few tricks that will help to mitigate or completely prevent z-fighting in your scene.

22.4.1 Prevent z-fighting

The first and most important trick is *never place objects too close to each other in a way that some of their triangles closely overlap*. By creating a small offset between two objects that is hardly noticeable by a user you'll completely remove z-fighting between the two objects. In the case of the containers and the plane we could've easily moved the containers slightly in the positive y direction. The small change of the container's positions would probably not be noticeable at all and completely reduce the z-fighting. However, this requires manual intervention of each of the objects and thorough testing to make sure no objects in a scene produce z-fighting.

A second trick is to *set the near plane as far as possible*. In one of the previous sections we've discussed that precision is extremely large when close to the near plane so if we move the near plane farther from the viewer, we'll have significantly greater precision over the entire frustum range. However, setting the near plane too far could cause clipping of near objects so it is usually a matter of tweaking and experimentation to figure out the best near distance for your scene.

Another great trick at the cost of some performance is to *use a higher precision depth buffer*. Most depth buffers have a precision of 24 bits, but most cards nowadays support 32 bit depth buffers which increases the precision by a significant amount. So at the cost of some performance you'll get much more precision with depth testing, reducing z-fighting.

The 3 techniques we've discussed are the most common and easy-to-implement anti z-fighting techniques. There are some other techniques out there that require a lot more work and still won't completely disable z-fighting. Z-fighting is a common issue, but if you use the proper combination of the listed techniques you probably won't really need to deal with z-fighting.

A futuristic cityscape with a flying vehicle in the foreground. The vehicle is dark with blue glowing lights and is flying towards the left. The city is composed of many tall, thin buildings, some with spires, and the sky is a hazy blue.

23. Stencil testing

Once the fragment shader has processed the fragment a so called **stencil test** is executed that, just like the depth test, has the possibility of discarding fragments. Then the remaining fragments get passed to the depth test that could possibly discard even more fragments. The stencil test is based on the content of yet another buffer called the **stencil buffer** that we're allowed to update during rendering to achieve interesting effects.

A stencil buffer (usually) contains 8 bits per **stencil value** that amounts to a total of 256 different stencil values per pixel/fragment. We can then set these stencil values to values of our liking and then we can discard or keep fragments whenever a particular fragment has a certain stencil value.

Each windowing library needs to set up a stencil buffer for you. GLFW does this automatically so we don't have to tell GLFW to create one, but other windowing libraries might not create a stencil library by default so be sure to check your library's documentation.

A simple example of a stencil buffer is shown below:

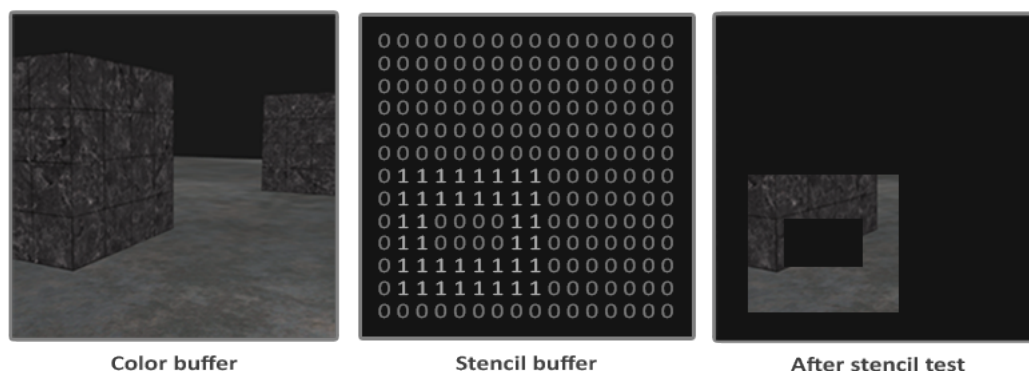

The stencil buffer is first cleared with zeros and then an open rectangle of 1s is set in the stencil buffer. The fragments of the scene are then only rendered (the others are discarded) wherever the stencil value of that fragment contains a 1.

Stencil buffer operations allow us to set the stencil buffer at specific values wherever we're rendering fragments. By changing the content of the stencil buffer while we're rendering, we're *writing* to the stencil buffer. In the same (or following) render iteration(s) we can then *read* these values to discard or pass certain fragments. When using stencil buffers you can get as crazy as you like, but the general outline is usually as follows:

- Enable writing to the stencil buffer.
- Render objects, updating the content of the stencil buffer.
- Disable writing to the stencil buffer.
- Render (other) objects, this time discarding certain fragments based on the content of the stencil buffer.

By using the stencil buffer we can thus discard certain fragments based on the fragments of other drawn objects in the scene.

You can enable stencil testing by enabling `GL_STENCIL_TEST`. From that point on, all rendering calls will influence the stencil buffer in one way or another.

```
glEnable(GL_STENCIL_TEST);
```

Note that you also need to clear the stencil buffer each iteration just like the color and depth buffer:

```
glClear(GL_COLOR_BUFFER_BIT | GL_DEPTH_BUFFER_BIT | GL_STENCIL_BUFFER_BIT);
```

Also, just like the depth testing's `glDepthMask` function, there is an equivalent function for the stencil buffer. The function `glStencilMask` allows us to set a bitmask that is ANDed with the stencil value about to be written to the buffer. By default this is set to a bitmask of all 1s unaffecteding the output, but if we were to set this to `0x00` all the stencil values written to the buffer end up as 0s. This is equivalent to depth testing's `glDepthMask(GL_FALSE)`:

```
glStencilMask(0xFF); // Each bit is written to the stencil buffer as is
glStencilMask(0x00); // Each bit ends up as 0 in the stencil buffer (
    disabling writes)
```

Most of the cases you'll just be writing `0x00` or `0xFF` as the stencil mask, but it's good to know there are options to set custom bit-masks.

23.1 Stencil functions

Just like with depth testing, we have a certain amount of control over when a stencil test should pass or fail and how it should affect the stencil buffer. There are a total of two functions we can use to configure stencil testing: `glStencilFunc` and `glStencilOp`.

The `glStencilFunc(GLenum func, GLint ref, GLuint mask)` has three parameters:

- `func`: sets the stencil test function. This test function is applied to the stored stencil value and the `glStencilFunc`'s `ref` value. Possible options are: `GL_NEVER`, `GL_LESS`, `GL_LEQUAL`, `GL_GREATER`, `GL_GEQUAL`, `GL_EQUAL`, `GL_NOTEQUAL` and `GL_ALWAYS`. The semantic meaning of these is similar to the depth buffer's functions.
- `ref`: specifies the reference value for the stencil test. The stencil buffer's content is compared to this value.
- `mask`: specifies a mask that is ANDed with both the reference value and the stored stencil value before the test compares them. Initially set to all 1s.

So in the case of the simple stencil example we've shown at the start the function would be set to:

```
glStencilFunc(GL_EQUAL, 1, 0xFF)
```

This tells OpenGL that whenever the stencil value of a fragment is equal (`GL_EQUAL`) to the reference value 1 the fragment passes the test and is drawn, otherwise discarded.

But `glStencilFunc` only described what OpenGL should do with the content of the stencil buffer, not how we can actually update the buffer. That is where `glStencilOp` comes in.

The `glStencilOp(GLenum sfail, GLenum dpfail, GLenum dppass)` contains three options of which we can specify for each option what action to take:

- `sfail`: action to take if the stencil test fails.
- `dpfail`: action to take if the stencil test passes, but the depth test fails.
- `dppass`: action to take if both the stencil and the depth test pass.

Then for each of the options you can take any of the following actions:

Action	Description
GL_KEEP	The currently stored stencil value is kept.
GL_ZERO	The stencil value is set to 0.
GL_REPLACE	The stencil value is replaced with the reference value set with <code>glStencilFunc</code> .
GL_INCR	The stencil value is increased by 1 if it is lower than the maximum value.
GL_INCR_WRAP	Same as <code>GL_INCR</code> , but wraps it back to 0 as soon as the maximum value is exceeded.
GL_DECR	The stencil value is decreased by 1 if it is higher than the minimum value.
GL_DECR_WRAP	Same as <code>GL_DECR</code> , but wraps it to the maximum value if it ends up lower than 0.
GL_INVERT	Bitwise inverts the current stencil buffer value.

By default the `glStencilOp` function is set to `(GL_KEEP, GL_KEEP, GL_KEEP)` so whatever the outcome of any of the tests, the stencil buffer keeps its values. The default behavior does not update the stencil buffer, so if you want to write to the stencil buffer you need to specify at least one different action for any of the options.

So using `glStencilFunc` and `glStencilOp` we can precisely specify when and how we want to update the stencil buffer and we can also specify when the stencil test should pass or not e.g. when fragments should be discarded.

23.2 Object outlining

It would be unlikely if you completely understood how stencil testing works from the previous sections alone so we're going to demonstrate a particular useful feature that can be implemented with stencil testing alone called `object outlining`.

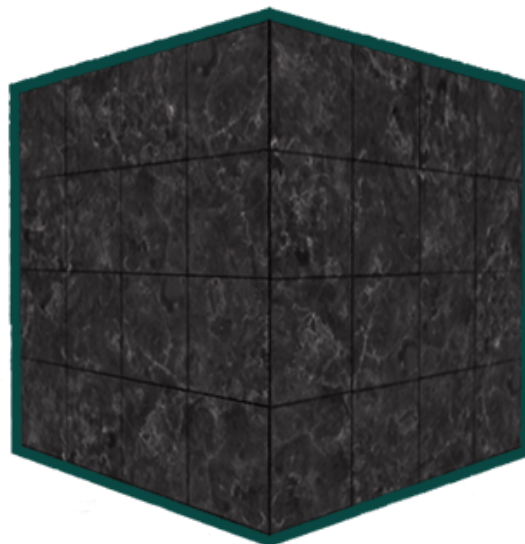

Object outlining does exactly what it says it does. For each object (or only one) we're creating a small colored border around the (combined) objects. This is a particular useful effect when you want to select units in a strategy game for example and need to show the user which of the units were selected. The routine for outlining your objects is as follows:

1. Set the stencil func to `GL_ALWAYS` before drawing the (to be outlined) objects, updating the stencil buffer with 1s wherever the objects' fragments are rendered.
2. Render the objects.
3. Disable stencil writing and depth testing.
4. Scale each of the objects by a small amount.
5. Use a different fragment shader that outputs a single (border) color.
6. Draw the objects again, but only if their fragments' stencil values are not equal to 1.
7. Enable stencil writing and depth testing again.

This process sets the content of the stencil buffer to 1s for each of the object's fragments and when we want to draw the borders, we basically draw scaled-up versions of the objects and wherever the stencil test passes, the scaled-up version is drawn which is around the borders of the object. We're basically discarding all the fragments of the scaled-up versions that are not part of the original objects' fragments using the stencil buffer.

So we're first going to create a very basic fragment shader that outputs a border color. We simply set a hardcoded color value and call the shader `shaderSingleColor`:

```
void main()
{
    outColor = vec4(0.04, 0.28, 0.26, 1.0);
}
```

We're only going to add object outlining to the two containers so we'll leave the floor out of it. We thus want to first draw the floor, then the two containers (while writing to the stencil buffer) and then we draw the scaled-up containers (while discarding the fragments that write over the previously drawn container fragments).

We first want to enable stencil testing and set the actions to take whenever any of the tests succeed or fail:

```
glEnable(GL_DEPTH_TEST);
glStencilOp(GL_KEEP, GL_KEEP, GL_REPLACE);
```

If any of the tests fail we do nothing, we simply keep the currently stored value that is in the stencil buffer. If both the stencil test and the depth test succeed however, we want to replace the stored stencil value with the reference value set via `glStencilFunc` which we later set to 1.

We clear the stencil buffer to 0s and for the containers we update the stencil buffer to 1 for each fragment drawn:

```
glStencilFunc(GL_ALWAYS, 1, 0xFF); // All fragments should update the
    stencil buffer
glStencilMask(0xFF); // Enable writing to the stencil buffer
normalShader.Use();
DrawTwoContainers();
```

By using the `GL_ALWAYS` stencil testing function we make sure that each of the containers' fragments update the stencil buffer with a stencil value of 1. Because the fragments always pass the stencil test, the stencil buffer is updated with the reference value wherever we've drawn them.

Now that the stencil buffer is updated with 1s where the containers were drawn we're going to draw the upscaled containers, but this time disabling writes to the stencil buffer:

```
glStencilFunc(GL_NOTEQUAL, 1, 0xFF);
glStencilMask(0x00); // Disable writing to the stencil buffer
glDisable(GL_DEPTH_TEST);
shaderSingleColor.Use();
DrawTwoScaledUpContainers();
```

We set the stencil function to `GL_NOTEQUAL` which makes sure that we're only drawing parts of the containers that are not equal to 1 thus only draw the part of the containers that are outside the previously drawn containers. Note that we also disable depth testing so the scaled up containers e.g. the borders do not get overwritten by the floor.

Also make sure to enable the depth buffer again once you're done.

The total object outlining routine for our scene will then look something like this:

```
glEnable(GL_DEPTH_TEST);
glStencilOp(GL_KEEP, GL_KEEP, GL_REPLACE);

glClear(GL_COLOR_BUFFER_BIT | GL_DEPTH_BUFFER_BIT | GL_STENCIL_BUFFER_BIT);

glStencilMask(0x00); // Make sure we don't update the stencil buffer while
    drawing the floor
normalShader.Use();
DrawFloor()

glStencilFunc(GL_ALWAYS, 1, 0xFF);
glStencilMask(0xFF);
DrawTwoContainers();

glStencilFunc(GL_NOTEQUAL, 1, 0xFF);
glStencilMask(0x00);
glDisable(GL_DEPTH_TEST);
shaderSingleColor.Use();
DrawTwoScaledUpContainers();
glStencilMask(0xFF);
glEnable(GL_DEPTH_TEST);
```

As long as you understand the general idea behind stencil testing this fragment of code shouldn't be too hard to understand. Otherwise try to carefully read the previous sections again and try to completely understand what each of the functions does now that you've seen an example of its usage.

The result of this outlining algorithm, in the scene from the [depth testing](#) tutorial, then looks like this:

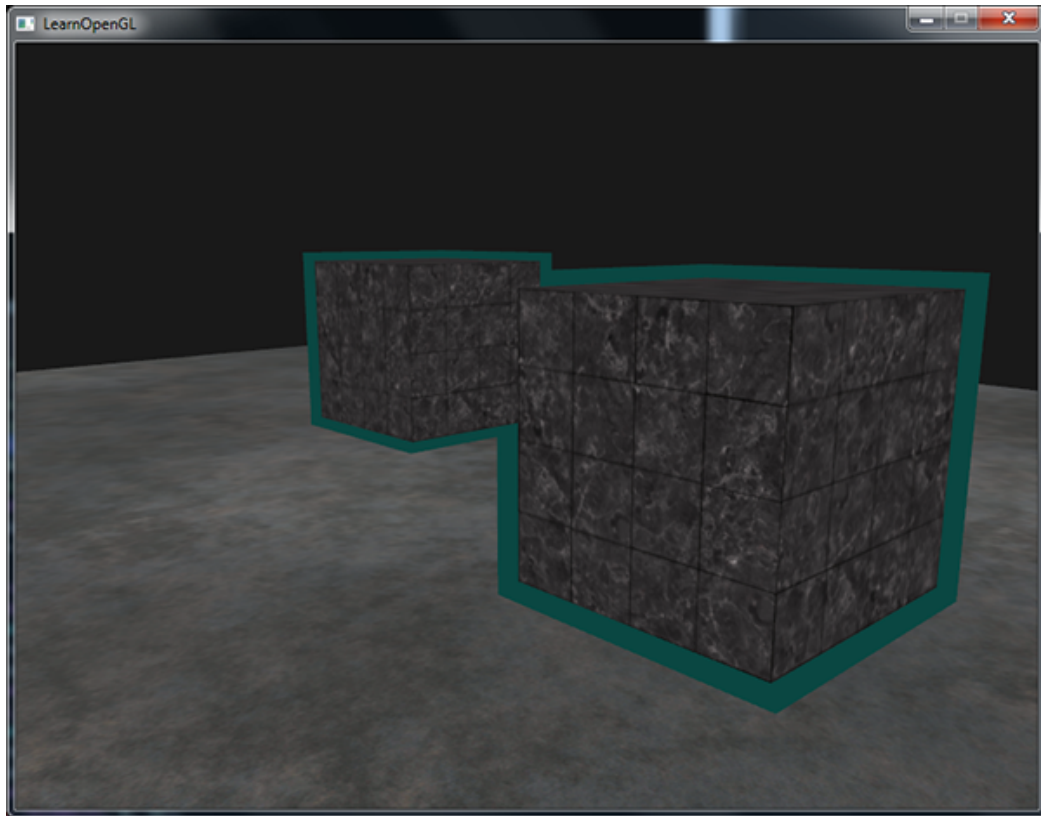

Check the source code [here](#) together with the [shaders](#) to see the complete code of the object outlining algorithm.

You can see that the borders overlap between both containers which is usually the effect that we want (think of strategy games where we want to select 10 units; merging borders is usually what we want). If you want a complete border per object you'd have to clear the stencil buffer per object and get a little creative with the depth buffer.

The object outlining algorithm you've seen is quite commonly used in several games to visualize selected objects (think of strategy games) and such an algorithm can easily be implemented within a model class. You could then simply set a boolean flag within the model class to draw with borders or without. If you want to be creative you could even give the borders a more natural look with the help of post-processing filters like Gaussian Blur.

Stencil testing has many more purposes, beside outlining objects, like drawing textures inside a rear-view mirror so it neatly fits into the mirror shape or rendering real-time shadows with a stencil buffer technique called [shadow volumes](#). Stencil buffers provide us with yet another nice tool in our already extensive OpenGL toolkit.

24. Blending

Blending in OpenGL is also commonly known as the technique to implement **transparency** within objects. Transparency is all about objects (or parts of them) not having a solid color, but having a combination of colors from the object itself and any other object behind it with varying intensity. A colored glass window is a transparent object; the glass has a color of its own, but the resulting color contains the colors of all the objects behind the glass as well. This is also where the name blending comes from, since we **blend** several colors (of different objects) to a single color. Transparency thus allows us to see through objects.



Full transparent window

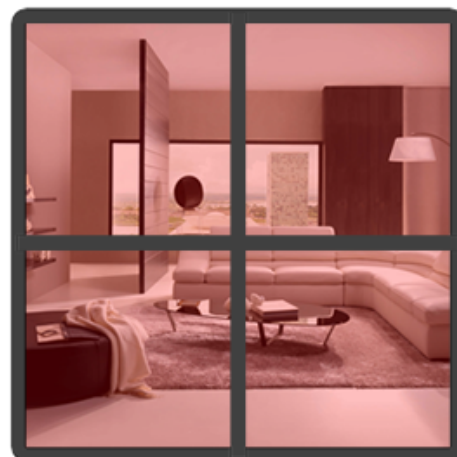

Partially transparent window

Transparent objects can be completely transparent (it lets all colors through) or partially transparent (it lets colors through, but also shows some of its own colors). The amount of transparency of an object is defined by its color's **alpha** value. The alpha color value is the 4th component of a color vector that you've probably seen quite often now. Until this tutorial, we've always kept this 4th component at a value of 1.0 giving the object 0.0 transparency, while an alpha value of 0.0

would result in the object having complete transparency. An alpha value of 0.5 tells us the object's color consist of 50% of its own color and 50% of the colors behind the object.

The textures we've used so far all consisted of 3 color components: red, green and blue, but some textures also have an embedded alpha channel that contains an **alpha** value per texel. This alpha value tells us exactly which parts of the texture have transparency and by how much. For example, the following **window texture** has an alpha value of 0.25 at its glass part (it would normally be completely red, but since it has 75% transparency it largely shows the website's background through it, making it seem a lot less red) and an alpha value of 0.0 at its corners:

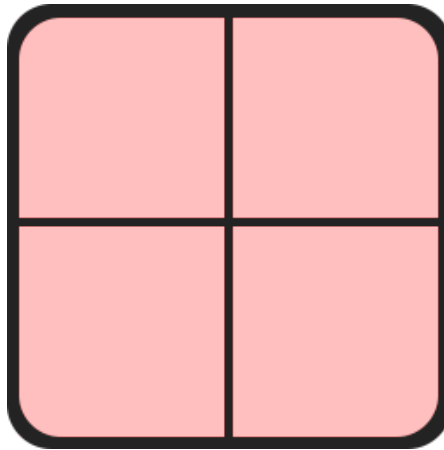

We'll soon be adding this windowed texture to the scene, but first we'll discuss an easier technique to implement transparency for textures that are either fully transparent or fully opaque.

24.1 Discarding fragments

Some images do not care about partial transparency, but either want to show something or nothing at all based on the color value of a texture. Think of grass; to create something like grass with little effort you generally paste a grass texture onto a 2D quad and place that quad into your scene. However, grass isn't exactly shaped like a 2D square so you only want to display some parts of the grass texture and ignore the others.

The following texture is exactly such a texture where it either is full opaque (an alpha value of 1.0) or it is fully transparent (an alpha value of 0.0) and nothing in between. You can see that wherever there is no grass, the image shows the website's background color instead of its own.



So when adding vegetation like grass to your scene we don't want to see a square image of grass, but rather only show the actual grass and be able to see through the rest of the image. We want to **discard** the fragments that show the transparent parts of the texture, not storing the fragment into the color buffer. Before we get into that we first need to learn how to load a transparent texture.

To load textures with alpha values we need to tell SOIL to load the RGBA components of the image instead of the RGB components. Note that SOIL will still load most alpha-less textures just fine, it simply stores an alpha value of 1.0 wherever one is omitted.

```
unsigned char* image = SOIL_load_image(path, &width, &height, 0,  
SOIL_LOAD_RGBA);
```

Don't forget to change the texture generation procedure as well:

```
glTexImage2D(GL_TEXTURE_2D, 0, GL_RGBA, width, height, 0, GL_RGBA,  
GL_UNSIGNED_BYTE, image);
```

Also make sure that you retrieve all 4 color components of the texture in the fragment shader, not just the RGB components:

```
void main()  
{  
    // color = vec4(vec3(texture(texture1, TexCoords)), 1.0);  
    color = texture(texture1, TexCoords);  
}
```

```
}
```

Now that we know how to load transparent textures it's time to put it to the test by adding several of these leaves of grass throughout the basic scene introduced in the [depth testing](#) tutorial.

We create a small vector where we add several `glm::vec3` variables to represent the location of the grass leaves:

```
vector<glm::vec3> vegetation;  
vegetation.push_back(glm::vec3(-1.5f, 0.0f, -0.48f));  
vegetation.push_back(glm::vec3( 1.5f, 0.0f, 0.51f));  
vegetation.push_back(glm::vec3( 0.0f, 0.0f, 0.7f));  
vegetation.push_back(glm::vec3(-0.3f, 0.0f, -2.3f));  
vegetation.push_back(glm::vec3( 0.5f, 0.0f, -0.6f));
```

Each of the grass objects is rendered as a single quad with the grass texture attached to it. It's not a perfect 3D representation of grass, but it's a lot more efficient than actually loading complex models. With a few tricks, like adding several more rotated grass quads at the same position, you can still get good results.

Because the grass texture is added to a quad object we'll need to create another VAO again, fill the VBO and set the appropriate vertex attribute pointers. Then after we've drawn the floor and the two cubes we're going to draw the grass leaves:

```
glBindVertexArray(vegetationVAO);  
glBindTexture(GL_TEXTURE_2D, grassTexture);  
for(GLuint i = 0; i < vegetation.size(); i++)  
{  
    model = glm::mat4();  
    model = glm::translate(model, vegetation[i]);  
    glUniformMatrix4fv(modelLoc, 1, GL_FALSE, glm::value_ptr(model));  
    glDrawArrays(GL_TRIANGLES, 0, 6);  
}  
glBindVertexArray(0);
```

Running your application will now probably look a bit like this:

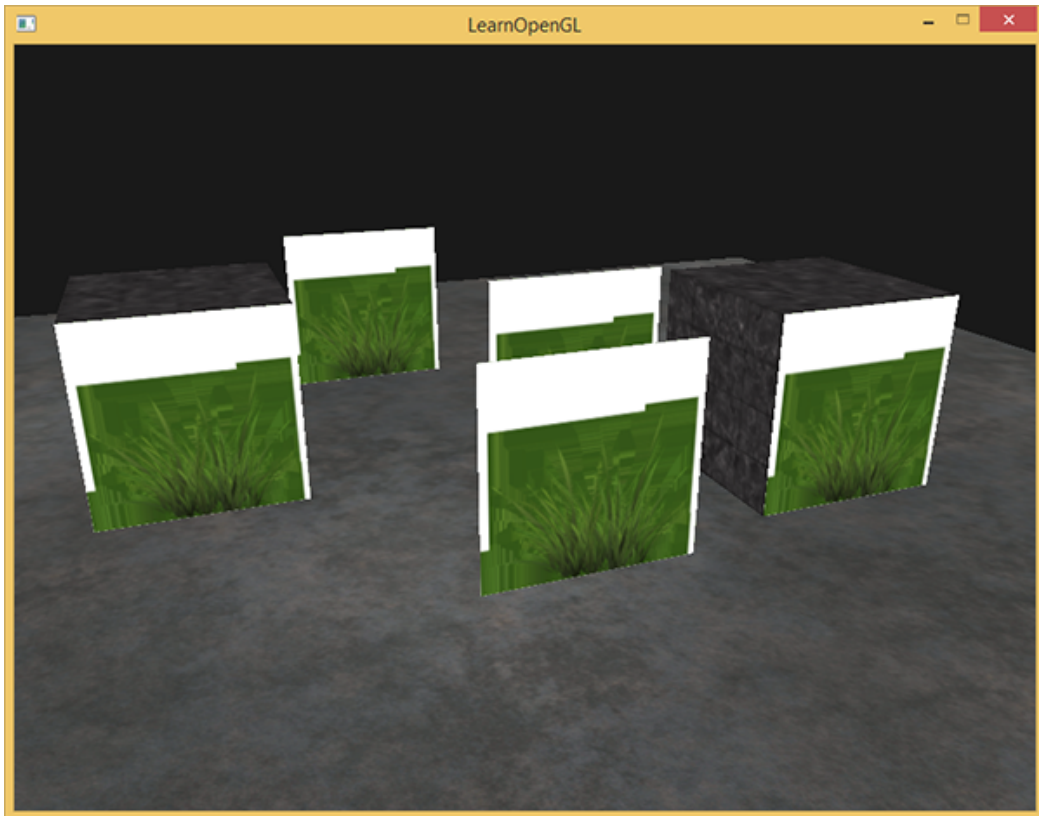

This happens because OpenGL by default does not know what to do with alpha values, nor when to discard them. We have to manually do this ourselves. Luckily this is quite easy thanks to the use of shaders. GLSL gives us the `discard` command that (once called) ensures the fragment will not be further processed and thus not end up into the color buffer. Thanks to this command we can check in the fragment shader whether a fragment gets an alpha value below a certain threshold and if so, discard the fragment as if it had never been processed:

```
#version 330 core
in vec2 TexCoords;

out vec4 color;

uniform sampler2D texture1;

void main()
{
    vec4 texColor = texture(texture1, TexCoords);
    if(texColor.a < 0.1)
        discard;
    color = texColor;
}
```

Here we check if the sampled texture color contains an alpha value lower than a threshold of 0.1 and if so, discard the fragment. This fragment shader ensures us that it only renders fragments that are not (almost) completely transparent. Now it'll look like it should:

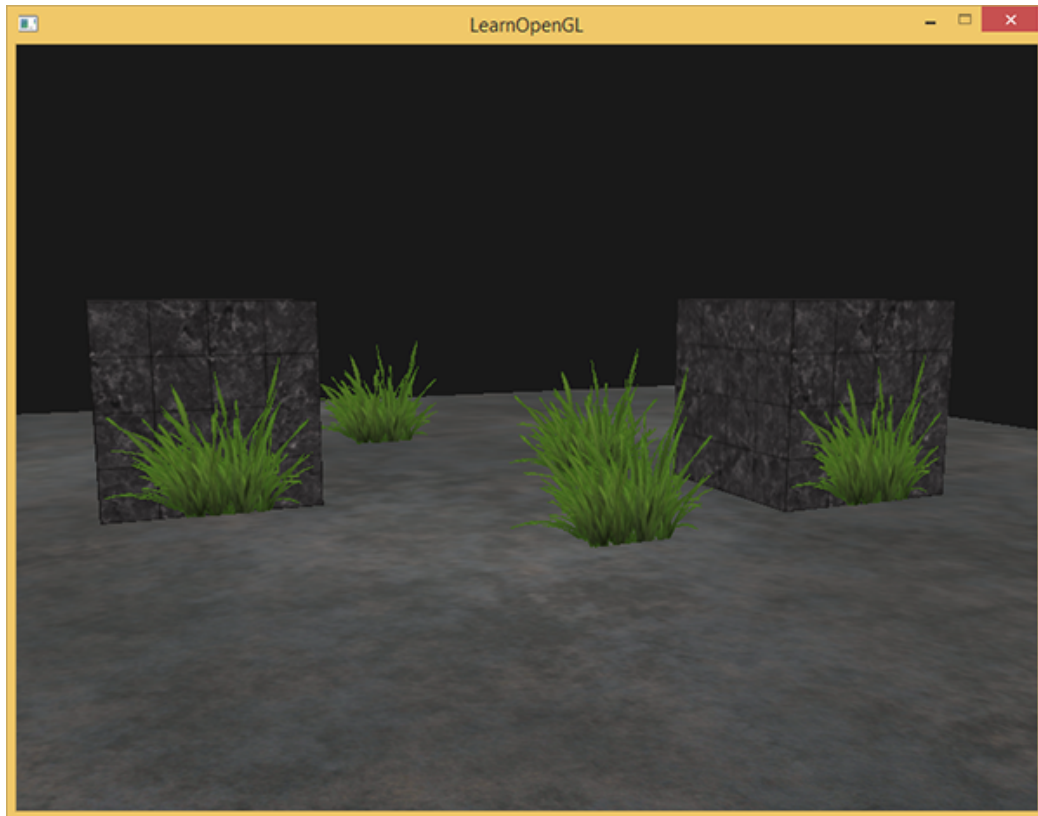

Note that when sampling textures at their borders, OpenGL interpolates the border values with the next repeated value of the texture (because we set its wrapping parameters to `GL_REPEAT`). This is usually okay, but since we're using transparent values, the top of the texture image gets its transparent value interpolated with the bottom border's solid color value. The result is then a slightly semi-transparent colored border you might see wrapped around your textured quad. To prevent this, set the texture wrapping method to `GL_CLAMP_TO_EDGE` whenever you use alpha textures:

```
glTexParameteri( GL_TEXTURE_2D, GL_TEXTURE_WRAP_S, GL_CLAMP_TO_EDGE);  
glTexParameteri( GL_TEXTURE_2D, GL_TEXTURE_WRAP_T, GL_CLAMP_TO_EDGE);
```

You can find the source code [here](#).

24.2 Blending

While discarding fragments is great and all, it doesn't give us the flexibility to render semi-transparent images; we either render the fragment or completely discard it. To render images with different levels of transparency we have to enable **blending**. Like most of OpenGL's functionality we can enable blending by enabling `GL_BLEND`:

```
glEnable( GL_BLEND );
```

Now that we've enabled blending we need to tell OpenGL **how** it should actually blend.

Blending in OpenGL is done with the following equation:

$$\bar{C}_{result} = \bar{C}_{source} * F_{source} + \bar{C}_{destination} * F_{destination} \quad (24.1)$$

- \bar{C}_{source} : the source color vector. This is the color vector that originates from the texture.
- $\bar{C}_{destination}$: the destination color vector. This is the color vector that is currently stored in the color buffer.
- F_{source} : the source factor value. Sets the impact of the alpha value on the source color.
- $F_{destination}$: the destination factor value. Sets the impact of the alpha value on the destination color.

After the fragment shader has run and all the tests have passed, this **blend equation** is let loose on the fragment's color output and with whatever is currently in the color buffer (previous fragment color stored before the current fragment). The source and destination colors will automatically be set by OpenGL, but the source and destination factor can be set to a value of our choosing. Let's start with a simple example:

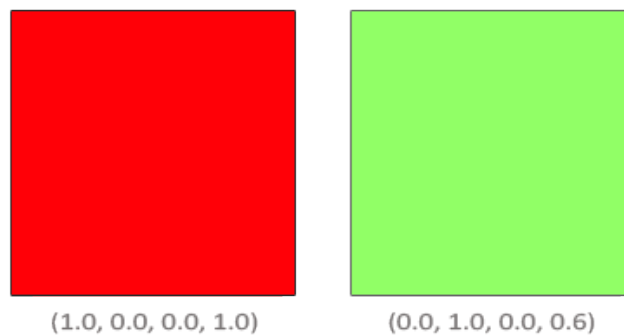

We have two squares where we want to draw the semi-transparent green square on top of the red square. The red square will be the destination color (and thus should be first in the color buffer) and we are now going to draw the green square over the red square.

The question then arises: what do we set the factor values to? Well, we at least want to multiply the green square with its alpha value so we want to set the F_{src} equal to the alpha value of the source color vector which is 0.6 . Then it makes sense to let the destination square have a contribution equal to the remainder of the alpha value. If the green square contributes 60% to the final color we want the red square to contribute 40% of the final color e.g. $1.0 - 0.6$. So we set the $F_{destination}$ equal to one minus the alpha value of the source color vector. The equation thus becomes:

$$\bar{C}_{result} = \begin{pmatrix} 0.0 \\ 1.0 \\ 0.0 \\ 0.6 \end{pmatrix} * 0.6 + \begin{pmatrix} 1.0 \\ 0.0 \\ 0.0 \\ 1.0 \end{pmatrix} * (1 - 0.6) \quad (24.2)$$

The result is that the combined square fragments contain a color that is 60% green and 40% red giving a dirty color:

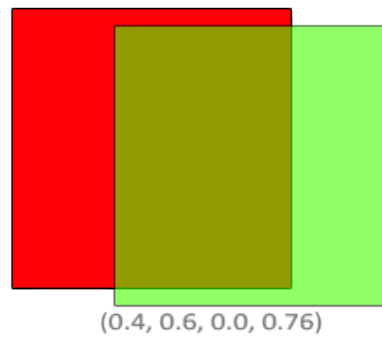

The resulting color is then stored in the color buffer, replacing the previous color.

So this is great and all, but how do we actually tell OpenGL to use factors like these? Well it just so happens that there is a function for this called `glBlendFunc`.

The `glBlendFunc(GLenum sfactor, GLenum dfactor)` function expects two parameters that set the option for the **source** and **destination factor**. OpenGL defined quite a few options for us to set of which we'll list the most common options below. Note that the constant color vector $\bar{C}_{constant}$ can be separately set via the `glBlendColor` function.

Option	Value
GL_ZERO	Factor is equal to 0.
GL_ONE	Factor is equal to 1.
GL_SRC_COLOR	Factor is equal to the source color vector \bar{C}_{source} .
GL_ONE_MINUS_SRC_COLOR	Factor is equal to 1 minus the source color vector: $1 - \bar{C}_{source}$.
GL_DST_COLOR	Factor is equal to the destination color vector $\bar{C}_{destination}$
GL_ONE_MINUS_DST_COLOR	Factor is equal to 1 minus the destination color vector: $1 - \bar{C}_{destination}$.
GL_SRC_ALPHA	Factor is equal to the <i>alpha</i> component of the source color vector \bar{C}_{source} .
GL_ONE_MINUS_SRC_ALPHA	Factor is equal to $1 - \alpha$ of the source color vector \bar{C}_{source} .
GL_DST_ALPHA	Factor is equal to the <i>alpha</i> component of the destination color vector $\bar{C}_{destination}$.
GL_ONE_MINUS_DST_ALPHA	Factor is equal to $1 - \alpha$ of the destination color vector $\bar{C}_{destination}$.
GL_CONSTANT_COLOR	Factor is equal to the constant color vector $\bar{C}_{constant}$.
GL_ONE_MINUS_CONSTANT_COLOR	Factor is equal to 1 - the constant color vector $\bar{C}_{constant}$.
GL_CONSTANT_ALPHA	Factor is equal to the <i>alpha</i> component of the constant color vector $\bar{C}_{constant}$.
GL_ONE_MINUS_CONSTANT_ALPHA	Factor is equal to $1 - \alpha$ of the constant color vector $\bar{C}_{constant}$.

To get the blending result we had from the two squares earlier, we want to take the *alpha* of the

source color vector for the source factor and $1 - \textit{alpha}$ for the destination factor. This translates to the `glBlendFunc` as follows:

```
glBlendFunc(GL_SRC_ALPHA, GL_ONE_MINUS_SRC_ALPHA);
```

It is also possible to set different options for the RGB and alpha channel individually using `glBlendFuncSeperate`:

```
glBlendFuncSeperate(GL_SRC_ALPHA, GL_ONE_MINUS_SRC_ALPHA, GL_ONE, GL_ZERO);
```

This function sets the RGB components as we've set them previously, but only lets the resulting alpha component be influenced by the source's alpha value.

OpenGL gives us even more flexibility by allowing us to change the operator between the source and destination part of the equation. Right now, the source and destination components are added together, but we could also subtract them if we want. `glBlendEquation(GLenum mode)` allows us to set this operation and has 3 possible options:

- `GL_FUNC_ADD`: the default, adds both components to each other: $\bar{C}_{result} = Src + Dst$.
- `GL_FUNC_SUBTRACT`: subtracts both components from each other: $\bar{C}_{result} = Src - Dst$.
- `GL_FUNC_REVERSE_SUBTRACT`: subtracts both components, but reverses order: $\bar{C}_{result} = Dst - Src$.

Usually we can simply omit a call to `glBlendEquation` because `GL_FUNC_ADD` is the preferred blending equation for most operations, but if you're really trying your best to break the mainstream circuit any of the other equations might suit your needs.

24.3 Rendering semi-transparent textures

Now that we know how OpenGL works with regards to blending it's time to put our knowledge to the test by adding several semi-transparent windows. We'll be using the same scene as in the start of this tutorial, but instead of rendering a grass texture we're now going to use the [transparent window](#) texture from the start of this tutorial.

First, during initialization we enable blending and set the appropriate blending function:

```
glEnable(GL_BLEND);
glBlendFunc(GL_SRC_ALPHA, GL_ONE_MINUS_SRC_ALPHA);
```

Since we enabled blending there is no need to discard fragments so we'll reset the fragment shader to its original version:

```
#version 330 core
in vec2 TexCoords;

out vec4 color;

uniform sampler2D texture1;

void main()
{
```

```
color = texture(texture1, TexCoords);  
}
```

This time (whenever OpenGL renders a fragment) it combines the current fragment's color with the fragment color currently in the color buffer based on its alpha value. Since the glass part of the window texture is semi-transparent we should be able to see the rest of the scene by looking through this window.

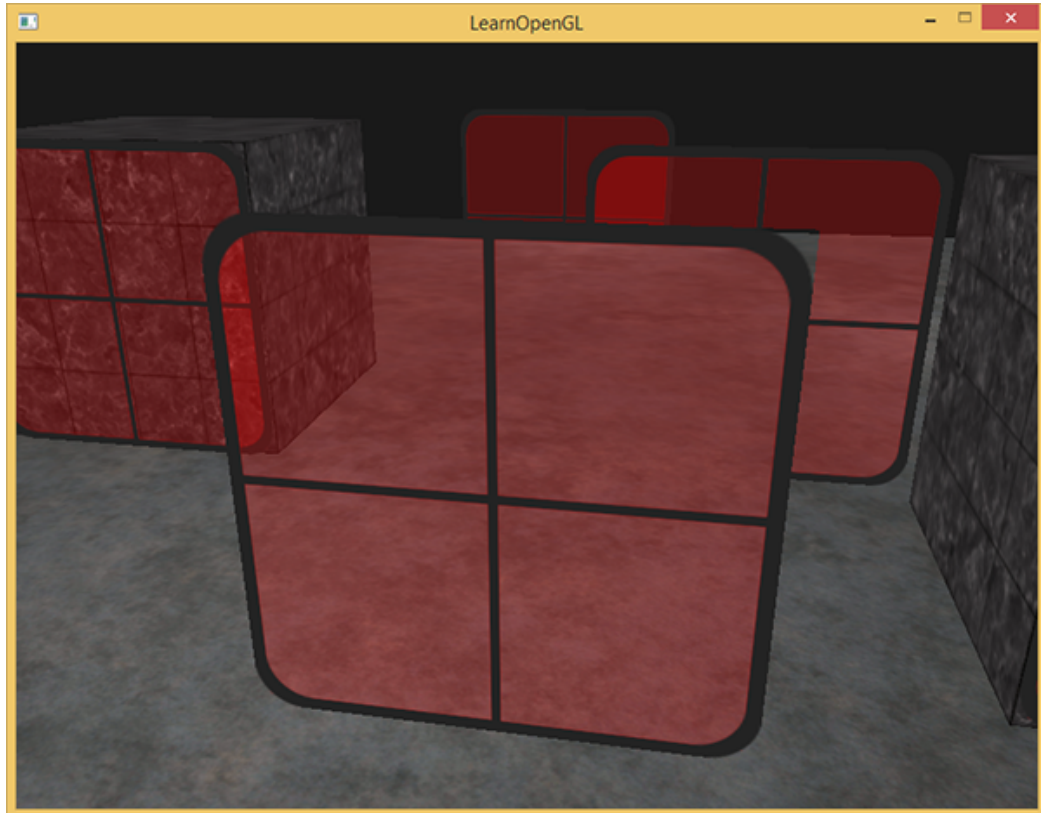

If you take a closer look however, you might notice something is off. The transparent parts of the front window are occluding the windows in the background. Why is this happening?

The reason for this is that depth testing works a bit tricky combined with blending. When writing to the depth buffer, the depth test does not care if the fragment has transparency or not so the transparent parts are written to the depth buffer as any other value. The result is that the entire quad of the window is checked for depth testing regardless of transparency. Even though the transparent part should show the windows behind it, the depth test discards them.

So we cannot simply render the windows however we want and expect the depth buffer to solve all our issues for us; this is also where blending gets a little nasty. To make sure the windows show the windows behind them, we have to draw the windows in the background first. This means we have to manually sort the windows from furthest to nearest and draw them accordingly ourselves.

Note that with fully transparent objects like the grass leaves we have the option to simply discard the transparent fragments instead of blending them, saving us a few of these headaches (no depth issues).

24.4 Don't break the order

To make blending work for multiple objects we have to draw the farthest object first and the closest object as last. The normal non-blended objects can still be drawn as normal using the depth buffer so they don't have to be sorted. We do have to make sure those are drawn first before drawing the (sorted) transparent objects. When drawing a scene with non-transparent and transparent objects the general outline is usually as follows:

1. Draw all opaque objects first.
2. Sort all the transparent objects.
3. Draw all the transparent objects in sorted order.

One way of sorting the transparent objects is to retrieve the distance of an object from the viewer's perspective. This can be achieved by taking the distance between the camera's position vector and the object's position vector. We then store this distance together with the corresponding position vector in a `map` data structure from the STL library. A `map` automatically sorts its values based on its keys, so once we've added all positions with their distance as the key they're automatically sorted on their distance value:

```
std::map<float, glm::vec3> sorted;
for (GLuint i = 0; i < windows.size(); i++) // windows contains all window
    positions
{
    GLfloat distance = glm::length(camera.Position - windows[i]);
    sorted[distance] = windows[i];
}
```

The result is a sorted container object that stores each of the window positions based on their `distance` key value from lowest to highest distance.

Then, this time when rendering, we take each of the `map`'s values in reverse order (from farthest to nearest) and then draw the corresponding windows in correct order:

```
for(std::map<float, glm::vec3>::reverse_iterator it = sorted.rbegin(); it !=
    sorted.rend(); ++it)
{
    model = glm::mat4();
    model = glm::translate(model, it->second);
    glUniformMatrix4fv(modelLoc, 1, GL_FALSE, glm::value_ptr(model));
    glDrawArrays(GL_TRIANGLES, 0, 6);
}
```

We take a reverse iterator from the `map` to iterate through each of the items in reverse order and then translate each window quad to the corresponding window position. This relatively simple approach to sorting transparent objects fixes the previous problem and now the scene looks like this:

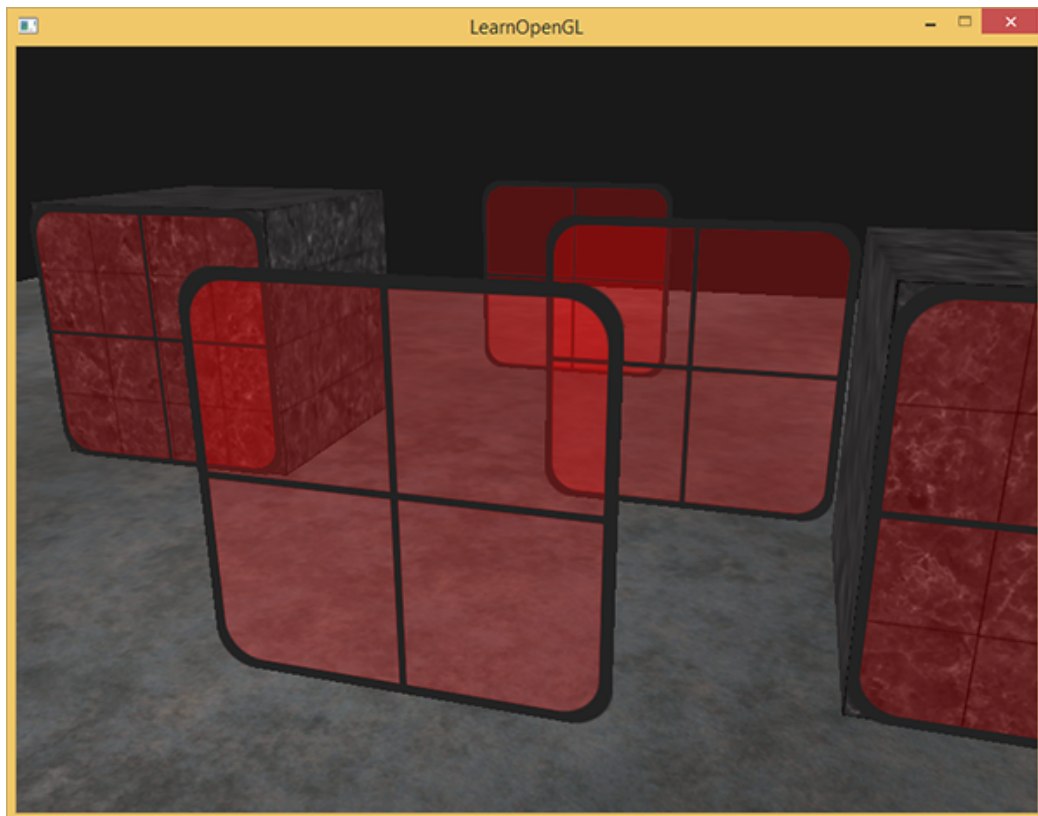

You can find the complete source code with sorting [here](#).

While this approach of sorting the objects by their distance works well for this specific scenario, it doesn't take rotations, scaling or any other transformation into account and weirdly shaped objects need a different metric than simply a position vector.

Sorting objects in your scene is a difficult feat that depends greatly on the type of scene you have, let alone the extra processing power it costs. Completely rendering a scene with solid and transparent objects isn't all that easy. There are more advanced techniques like [order independent transparency](#) but these are out of the scope of this tutorial. For now you'll have to live with normally blending your objects, but if you're careful and know the limitations you can still get fairly decent blending implementations.



25. Face culling

Try mentally visualizing a 3D cube and count the maximum number of faces you'll be able to see from any direction. If your imagination is not too creative you probably ended up with a maximum number of 3. You can view a cube from any position and/or direction, but you would never be able to see more than 3 faces. So why would we waste the effort of actually drawing those other 3 faces that we can't even see. If we could discard those in some way we would save more than 50% of fragment shader runs!

We say *more than 50%* instead of 50%, because from certain angles only 2 or even 1 face could be visible. In that case we'd save **more** than 50%.

This is a really great idea, but there's one problem we need to solve: how do we know if a face of an object is not visible from the viewer's point of view? If we imagine any closed shape, each of its faces has two sides. Each side would either *face* the user or show its back to the user. What if we could only render the faces that are *facing* the viewer?

This is exactly what **face culling** does. OpenGL checks all the faces that are **front facing** towards the viewer and renders those while discarding all the faces that are **back facing** saving us a lot of fragment shader calls (those are expensive!). We do need to tell OpenGL which of the faces we use are actually the front faces and which faces are the back faces. OpenGL uses a clever trick for this by analyzing the **winding order** of the vertex data.

25.1 Winding order

When we define a set of triangle vertices we're defining them in a certain winding order that is either **clockwise** or **counter-clockwise**. Each triangle consists of 3 vertices and we specify those 3 vertices in a winding order as seen from the center of the triangle.

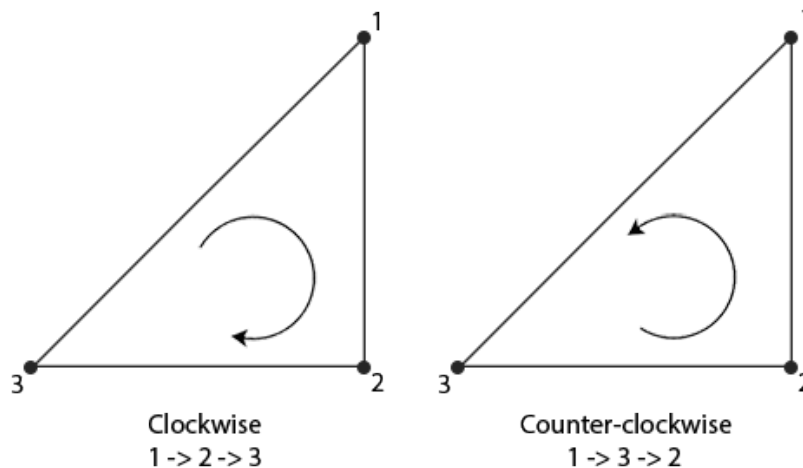

As you can see in the image we first define the vertex 1 and then we can either define vertex 2 or 3 and this choice defines the winding order of this triangle. The following code illustrates this:

```
GLfloat vertices[] = {
    // Clockwise
    vertices[0], // vertex 1
    vertices[1], // vertex 2
    vertices[2], // vertex 3
    // Counter-clockwise
    vertices[0], // vertex 1
    vertices[2], // vertex 3
    vertices[1] // vertex 2
};
```

Each set of 3 vertices that form a triangle primitive thus contain a winding order. OpenGL uses this information when rendering your primitives to determine if a triangle is a **front-facing** or a **back-facing** triangle. By default, triangles defined with counter-clockwise vertices are processed as front-facing triangles.

When defining your vertex order you visualize the corresponding triangle as if it was facing you, so each triangle that you're specifying should be counter-clockwise as if you're directly facing that triangle. The cool thing about specifying all your vertices like this is that the actual winding order is calculated at the rasterization stage, so when the vertex shader has already run. The vertices are then seen as from the **viewer's point of view**.

All the triangle vertices that the viewer is then facing are indeed in the correct winding order as we specified them, but the vertices of the triangles at the other side of the cube are now rendered in such a way that their winding order becomes reversed. The result is that the triangles we're facing are seen as front-facing triangles and the triangles at the back are seen as back-facing triangles. The following image shows this effect:

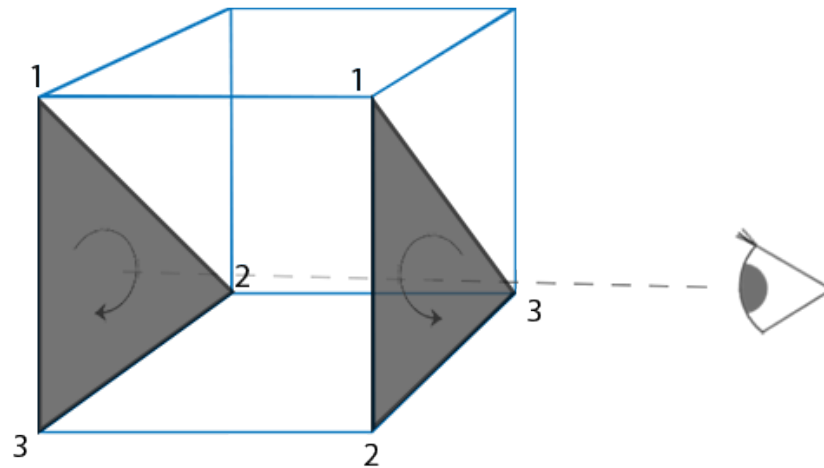

In the vertex data we would've defined both triangles in counter-clockwise order (the front triangle as 1, 2, 3 and the back triangle as 1, 2 and 3 as well (if we'd see the triangle from the front)). However, from the viewer's direction the back triangle is rendered clockwise if we draw it in the order of 1, 2 and 3 from the viewer's current point of view. Even though we specified the back triangle in counter-clockwise order, it is now rendered in a clockwise order. This is exactly what we want to **cull** (discard) non-visible faces!

25.2 Face culling

At the start of the tutorial we said that OpenGL is able to discard triangle primitives if they're rendered as back-facing triangles. Now that we know how to set the winding order of the vertices we can start using OpenGL's **face culling** option which is disabled by default.

The cube vertex data we used in the last tutorials wasn't defined with the counter-clockwise winding order in mind, so I updated the vertex data to reflect a counter-clockwise winding order which you can copy from [here](#). It's a good practice to try and visualize that these vertices are indeed all defined in a counter-clockwise order for each triangle.

To enable face culling we only have to enable OpenGL's `GL_CULL_FACE` option:

```
glEnable(GL_CULL_FACE);
```

From this point on, all the faces that are not front-faces are discarded (try flying inside the cube to see that all inner faces are indeed discarded). Currently we save over 50% of performance on rendering fragments, but do note that this only works with closed shapes like a cube. We'll have to disable face culling again when we draw the grass leaves from the [previous](#) tutorial for example, since their front **and** back face should be visible.

OpenGL allows us to change the type of face we want to cull as well. What if we want to cull front faces and not the back faces? We can define this behavior by calling `glCullFace`:

```
glCullFace(GL_BACK);
```

The `glCullFace` function has three possible options:

- `GL_BACK`: Culls only the back faces.
- `GL_FRONT`: Culls only the front faces.
- `GL_FRONT_AND_BACK`: Culls both the front and back faces.

The initial value of `glCullFace` is `GL_BACK`. Aside from the faces to cull we can also tell OpenGL we'd rather prefer clockwise faces as the front-faces instead of counter-clockwise faces via `glFrontFace`:

```
glFrontFace(GL_CCW);
```

The default value is `GL_CCW` that stands for counter-clockwise ordering with the other option being `GL_CW` which (obviously) stands for clockwise ordering.

As a simple test we could reverse the winding order by telling OpenGL that the front-faces are now determined by a clockwise ordering instead of a counter-clockwise ordering:

```
glEnable(GL_CULL_FACE);  
glCullFace(GL_BACK);  
glFrontFace(GL_CW);
```

The result is that only the back faces are rendered:

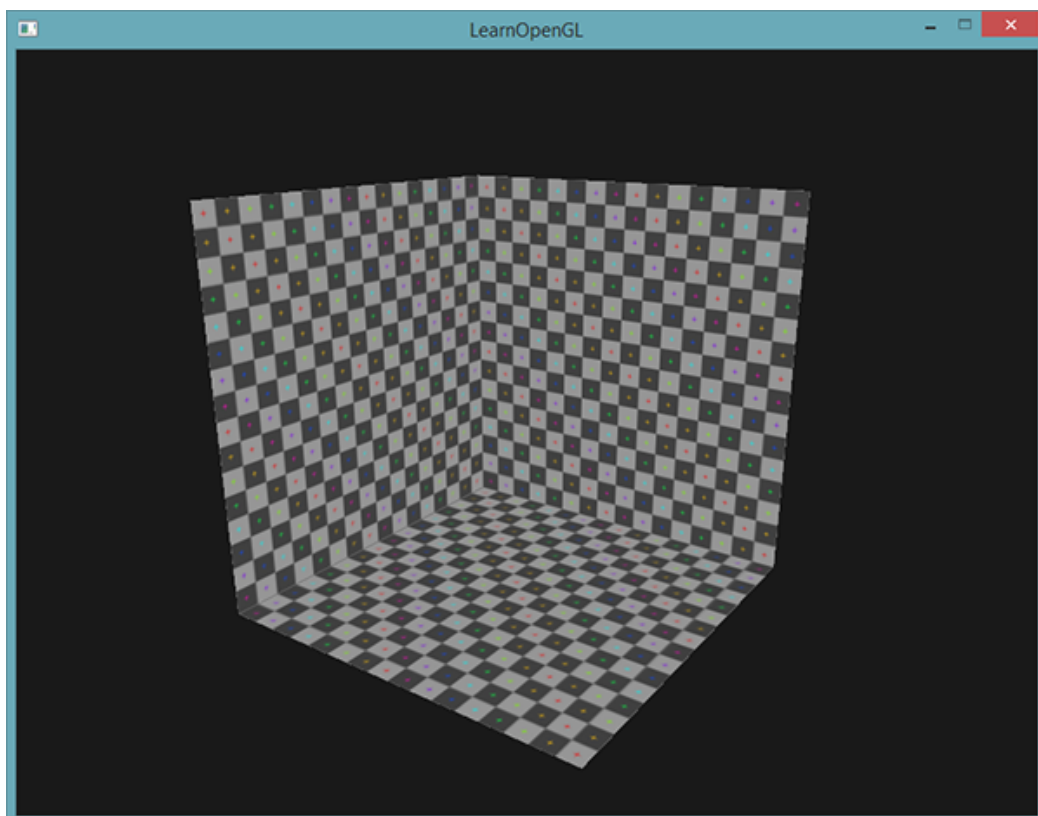

Note that you can create the same effect by culling front faces with the default counter-clockwise winding order:

```
glEnable(GL_CULL_FACE);  
glCullFace(GL_FRONT);
```

As you can see, face culling is a great tool for increasing performance of your OpenGL applications with minimal effort. You do have to keep track of which objects will actually benefit from face culling and which objects shouldn't be culled.

25.3 Exercises

- Can you re-define the vertex data by specifying each triangle in clockwise order and then render the scene with clockwise triangles set as the front faces: [solution](#)



26. Framebuffers

So far we've used several types of screen buffers: a color buffer for writing color values, a depth buffer to write depth information and finally a stencil buffer that allows us to discard certain fragments based on some condition. The combination of these buffers is called a **framebuffer** and is stored somewhere in memory. OpenGL gives us the flexibility to define our own framebuffers and thus define our own color and optionally a depth and stencil buffer.

The rendering operations we've done so far were all done on top of the render buffers attached to the **default framebuffer**. The default framebuffer is created and configured when you create your window (GLFW does this for us). By creating our own framebuffer we can get an additional means to render to.

The application of framebuffers might not immediately make sense, but rendering your scene to a different framebuffer allows us to create mirrors in a scene or do cool post-processing effects for example. First we'll discuss how they actually work and then we'll use them by implementing those cool post-processing effects.

26.1 Creating a framebuffer

Just like any other object in OpenGL we can create a framebuffer object (abbreviated to FBO) by using a function called `glGenFramebuffers`:

```
GLuint fbo;  
glGenFramebuffers(1, &fbo);
```

This pattern of object creation and usage is something we've seen dozens of times now so their usage functions are similar to all the other object's we've seen; first we create a framebuffer object, bind it as the active framebuffer, do some operations and unbind the framebuffer. To bind the framebuffer we use `glBindFramebuffer`:

```
glBindFramebuffer(GL_FRAMEBUFFER, fbo);
```

By binding to the `GL_FRAMEBUFFER` target all the next *read* and *write* framebuffer operations will affect the currently bound framebuffer. It is also possible to bind a framebuffer to a read or write target specifically by binding to `GL_READ_FRAMEBUFFER` or `GL_DRAW_FRAMEBUFFER` respectively. The framebuffer bound to `GL_READ_FRAMEBUFFER` is then used for all read operations like `glReadPixels` and the framebuffer bound to `GL_DRAW_FRAMEBUFFER` is used as the destination for rendering, clearing and other write operations. Most of the times you won't need to make this distinction though and you generally bind to both with `GL_FRAMEBUFFER`.

Unfortunately, we can't use our framebuffer yet because it is not *complete*. For a framebuffer to be complete the following requirements have to be satisfied:

- We have to attach at least one buffer (color, depth or stencil buffer).
- There should be at least one color attachment.
- All attachments should be complete as well (reserved memory).
- Each buffer should have the same number of samples.

Don't worry if you don't know what samples are, we'll get to those in a [later](#) tutorial.

From the requirements it should be clear that we need to create some kind of attachment for the framebuffer and attach this attachment to the framebuffer. After we've completed all requirements we can check if we actually successfully completed the framebuffer by calling `glCheckFramebufferStatus` with `GL_FRAMEBUFFER`. It then checks the currently bound framebuffer and returns any of [these](#) values found in the specification. If it returns `GL_FRAMEBUFFER_COMPLETE` we're good to go:

```
if(glCheckFramebufferStatus(GL_FRAMEBUFFER) == GL_FRAMEBUFFER_COMPLETE)
    // Execute victory dance
```

All subsequent rendering operations will now render to the attachments of the currently bound framebuffer. Since our framebuffer is not the default framebuffer, the rendering commands will have no impact on the visual output of your window. For this reason it is called *off-screen rendering* while rendering to a different framebuffer. To make sure all rendering operations will have a visual impact on the main window we need to make the default framebuffer active again by binding to 0:

```
glBindFramebuffer(GL_FRAMEBUFFER, 0);
```

When we're done with all framebuffer operations, do not forget to delete the framebuffer object:

```
glDeleteFramebuffers(1, &fbo);
```

Now before the completeness check is executed we need to attach one or more attachments to the framebuffer. An *attachment* is a memory location that can act as a buffer for the framebuffer, think of it as an image. When creating an attachment we have two options to take: textures or *renderbuffer* objects.

26.1.1 Texture attachments

When attaching a texture to a framebuffer, all rendering commands will write to the texture as if it was a normal color/depth or stencil buffer. The advantage of using textures is that the result of all rendering operations will be stored as a texture image that we can then easily use in our shaders.

Creating a texture for a framebuffer is roughly the same as a normal texture:

```
GLuint texture;
glGenTextures(1, &texture);
glBindTexture(GL_TEXTURE_2D, texture);

glTexImage2D(GL_TEXTURE_2D, 0, GL_RGB, 800, 600, 0, GL_RGB,
             GL_UNSIGNED_BYTE, NULL);

glTexParameteri(GL_TEXTURE_2D, GL_TEXTURE_MIN_FILTER, GL_LINEAR);
glTexParameteri(GL_TEXTURE_2D, GL_TEXTURE_MAG_FILTER, GL_LINEAR);
```

The main differences here is that we set the dimensions equal to the screen size (although this is not required) and we pass `NULL` as the texture's data parameter. For this texture, we're only allocating memory and not actually filling it. Filling the texture will happen as soon as we render to the framebuffer. Also note that we do not care about any of the wrapping methods or mipmapping since we won't be needing those in most cases.

If you want to render your whole screen to a texture of a smaller or larger size you need to call `glViewport` again (before rendering to your framebuffer) with the new dimensions of your texture, otherwise only a small part of the texture or screen would be drawn onto the texture.

Now that we've created a texture the last thing we need to do is actually attach it to the framebuffer:

```
glFramebufferTexture2D(GL_FRAMEBUFFER, GL_COLOR_ATTACHMENT0, GL_TEXTURE_2D,
                       texture, 0);
```

The `glFramebufferTexture2D` has the following parameters:

- `target`: the framebuffer type we're targeting (draw, read or both).
- `attachment`: the type of attachment we're going to attach. Right now we're attaching a color attachment. Note that the 0 at the end suggests we can attach more than 1 color attachment. We'll get to that in a later tutorial.
- `textarget`: the type of the texture you want to attach.
- `texture`: the actual texture to attach.
- `level`: the mipmap level. We keep this at 0.

Aside from the color attachments we can also attach a depth and a stencil texture to the framebuffer object. To attach a depth attachment we specify the attachment type as `GL_DEPTH_ATTACHMENT`. Note that the texture's `format` and `internalformat` type should then become `GL_DEPTH_COMPONENT` to reflect the depth buffer's storage format. To attach a stencil buffer you use `GL_STENCIL_ATTACHMENT` as the second argument and specify the texture's formats as `GL_STENCIL_INDEX`.

It is also possible to attach both a depth buffer and a stencil buffer as a single texture. Each 32 bit value of the texture then consists for 24 bits of depth information and 8 bits of stencil information. To

attach a depth and stencil buffer as one texture we use the `GL_DEPTH_STENCIL_ATTACHMENT` type and configure the texture's formats to contain combined depth and stencil values. An example of attaching a depth and stencil buffer as one texture to the framebuffer is given below:

```
glTexImage2D(
    GL_TEXTURE_2D, 0, GL_DEPTH24_STENCIL8, 800, 600, 0,
    GL_DEPTH_STENCIL, GL_UNSIGNED_INT_24_8, NULL
);

glFramebufferTexture2D(GL_FRAMEBUFFER, GL_DEPTH_STENCIL_ATTACHMENT,
    GL_TEXTURE_2D, texture, 0);
```

26.1.2 Renderbuffer object attachments

Renderbuffer objects were introduced to OpenGL after textures as a possible type of framebuffer attachments, so textures were the only attachments used in the good old days. Just like a texture image, a renderbuffer object is an actual buffer e.g. an array of bytes, integers, pixels or whatever. A renderbuffer object has the added advantage though that it stores its data in OpenGL's native rendering format making it optimized for off-screen rendering to a framebuffer.

Renderbuffer objects store all the render data directly into their buffer without any conversions to texture-specific formats, thus making them faster as a writeable storage medium. However, renderbuffer objects are generally write-only, thus you cannot read from them (like with texture-access). It is possible to read from them via `glReadPixels` though that returns a specified area of pixels from the currently bound framebuffer, but not directly from the attachment itself.

Because their data is already in its native format they are quite fast when writing data or simply copying their data to other buffers. Operations like switching buffers are thus quite fast when using renderbuffer objects. The `glfwSwapBuffers` function we've been using at the end of each render iteration might as well be implemented with renderbuffer objects: we simply write to a renderbuffer image, and swap to the other one at the end. Renderbuffer objects are perfect for these kind of operations.

Creating a renderbuffer object looks similar to the framebuffer's code:

```
GLuint rbo;
glGenRenderbuffers(1, &rbo);
```

And similarly we want to bind the renderbuffer object so all subsequent renderbuffer operations affect the current `rbo`:

```
glBindRenderbuffer(GL_RENDERBUFFER, rbo);
```

Since renderbuffer objects are generally write-only they are often used as depth and stencil attachments, since most of the time we don't really need to read values from the depth and stencil buffers but still care about depth and stencil testing. We **need** the depth and stencil values for testing, but don't need to *sample* these values so a renderbuffer object suits this perfectly. When we're not sampling from these buffers, a renderbuffer object is generally preferred since it's more optimized.

Creating a depth and stencil renderbuffer object is done by calling the `glRenderbufferStorage` function:

```
glRenderbufferStorage(GL_RENDERBUFFER, GL_DEPTH24_STENCIL8, 800, 600);
```

Creating a renderbuffer object is similar to texture objects, the difference being that this object is specifically designed to be used as an image, instead of a general purpose data buffer like a texture. Here we've chosen the `GL_DEPTH24_STENCIL8` as the internal format, which holds both the depth and stencil buffer with 24 and 8 bits respectively.

Last thing left to do is actually attach the renderbuffer object:

```
glFramebufferRenderbuffer(GL_FRAMEBUFFER, GL_DEPTH_STENCIL_ATTACHMENT,  
GL_RENDERBUFFER, rbo);
```

Renderbuffer objects could provide some optimizations in your framebuffer projects, but it is important to realize when to use renderbuffer objects and when to use textures. The general rule is that if you never need to sample data from a specific buffer, it is wise to use a renderbuffer object for that specific buffer. If you need to someday sample data from a specific buffer like colors or depth values, you should use a texture attachment instead. Performance-wise it doesn't have an enormous impact though.

26.2 Rendering to a texture

Now that we know how framebuffers (sort of) work it's time to put them to good use. We're going to render the scene into a color texture attached to a framebuffer object we created and then draw this texture over a simple quad that spans the whole screen. The visual output is then exactly the same as without a framebuffer, but this time it's all printed on top of a single quad. Now why is this useful? In the next section we'll see why.

First thing to do is to create an actual framebuffer object and bind it, this is all relatively straightforward:

```
GLuint framebuffer;  
glGenFramebuffers(1, &framebuffer);  
glBindFramebuffer(GL_FRAMEBUFFER, framebuffer);
```

Next we create a texture image that we attach as a color attachment to the framebuffer. We set the texture's dimensions equal to the width and height of the window and keep its data uninitialized:

```
// Generate texture  
GLuint texColorBuffer;  
glGenTextures(1, &texColorBuffer);  
glBindTexture(GL_TEXTURE_2D, texColorBuffer);  
glTexImage2D(GL_TEXTURE_2D, 0, GL_RGB, 800, 600, 0, GL_RGB,  
GL_UNSIGNED_BYTE, NULL);  
glTexParameteri(GL_TEXTURE_2D, GL_TEXTURE_MIN_FILTER, GL_LINEAR);  
glTexParameteri(GL_TEXTURE_2D, GL_TEXTURE_MAG_FILTER, GL_LINEAR);  
glBindTexture(GL_TEXTURE_2D, 0);
```

```
// Attach it to currently bound framebuffer object
glFramebufferTexture2D(GL_FRAMEBUFFER, GL_COLOR_ATTACHMENT0, GL_TEXTURE_2D,
    texColorBuffer, 0);
```

We also want to make sure OpenGL is able to do depth testing (and optionally stencil testing if you're into that) so we have to make sure to add a depth (and stencil) attachment to the framebuffer as well. Since we'll only be sampling the color buffer and not the other buffers we can create a renderbuffer object for this purpose. Remember that they're a good choice when you're not going to sample from the specific buffer(s)?

Creating a renderbuffer object isn't too hard. The only thing we have to remember is that we're creating it as a depth **and** stencil attachment renderbuffer object. We set its *internal format* to `GL_DEPTH24_STENCIL8` which is enough precision for our purposes.

```
GLuint rbo;
glGenRenderbuffers(1, &rbo);
glBindRenderbuffer(GL_RENDERBUFFER, rbo);
glRenderbufferStorage(GL_RENDERBUFFER, GL_DEPTH24_STENCIL8, 800, 600);
glBindRenderbuffer(GL_RENDERBUFFER, 0);
```

Once we've allocated enough memory for the renderbuffer object we can unbind the renderbuffer.

Then, as a final step before we can complete the framebuffer, we attach the renderbuffer object to the depth **and** stencil attachment of the framebuffer:

```
glFramebufferRenderbuffer(GL_FRAMEBUFFER, GL_DEPTH_STENCIL_ATTACHMENT,
    GL_RENDERBUFFER, rbo);
```

Then as a final measure we want to check if the framebuffer is actually complete and if it's not, we print an error message.

```
if(glCheckFramebufferStatus(GL_FRAMEBUFFER) != GL_FRAMEBUFFER_COMPLETE)
    cout << "ERROR::FRAMEBUFFER:: Framebuffer is not complete!" << endl;
glBindFramebuffer(GL_FRAMEBUFFER, 0);
```

Then also be sure to unbind the framebuffer to make sure we're not accidentally rendering to the wrong framebuffer.

Now that the framebuffer is complete all we need to do to render to the framebuffer's buffers instead of the default framebuffers is simply bind to the framebuffer object. All subsequent rendering commands will then influence the currently bound framebuffer. All the depth and stencil operations will also read from the currently bound framebuffer's depth and stencil attachments if they're available. If you were to omit a depth buffer for example, all depth testing operations will no longer work, because there's not a depth buffer present in the currently bound framebuffer.

So, to draw the scene to a single texture we'll have to take the following steps:

1. Render the scene as usual with the new framebuffer bound as the active framebuffer.
2. Bind to the default framebuffer.

3. Draw a quad that spans the entire screen with the new framebuffer's color buffer as its texture.

We'll draw the same scene we've used in the [depth testing](#) tutorial, but this time with the old-school [container](#) texture.

To draw the quad we're going to create a fresh set of simple shaders. We're not going to include any fancy matrix transformations since we'll just be supplying the [vertex coordinates as normalized device coordinates](#) so we can directly specify them as the output of the vertex shader. The vertex shader looks like this:

```
#version 330 core
layout (location = 0) in vec2 position;
layout (location = 1) in vec2 texCoords;

out vec2 TexCoords;

void main()
{
    gl_Position = vec4(position.x, position.y, 0.0f, 1.0f);
    TexCoords = texCoords;
}
```

Nothing too fancy. The fragment shader will be even more basic since the only thing we have to do is sample from a texture:

```
#version 330 core
in vec2 TexCoords;
out vec4 color;

uniform sampler2D screenTexture;

void main()
{
    color = texture(screenTexture, TexCoords);
}
```

It is then up to you to create and configure a VAO for the screen quad. A render iteration of the framebuffer procedure then has the following structure:

```
// First pass
glBindFramebuffer(GL_FRAMEBUFFER, framebuffer);
glClearColor(0.1f, 0.1f, 0.1f, 1.0f);
glClear(GL_COLOR_BUFFER_BIT | GL_DEPTH_BUFFER_BIT); // We're not using
    stencil buffer now
glEnable(GL_DEPTH_TEST);
DrawScene();

// Second pass
glBindFramebuffer(GL_FRAMEBUFFER, 0); // back to default
glClearColor(1.0f, 1.0f, 1.0f, 1.0f);
glClear(GL_COLOR_BUFFER_BIT);

screenShader.Use();
glBindVertexArray(quadVAO);
glDisable(GL_DEPTH_TEST);
glBindTexture(GL_TEXTURE_2D, textureColorbuffer);
glDrawArrays(GL_TRIANGLES, 0, 6);
```

```
glBindVertexArray(0);
```

There are a few things to note. First, since each framebuffer we're using has its own set of buffers, we want to clear each of those buffers with the appropriate bits set by calling `glClear`. Second, when drawing the quad, we're disabling depth testing since we don't really care about depth testing because we're drawing a simple quad; we'll have to enable depth testing again when we draw the normal scene though.

There are quite some steps that could go wrong here, so if you have no output, try to debug where possible and re-read the relevant sections of the tutorial. If everything did work out successfully you'll get a visual result that looks like this:

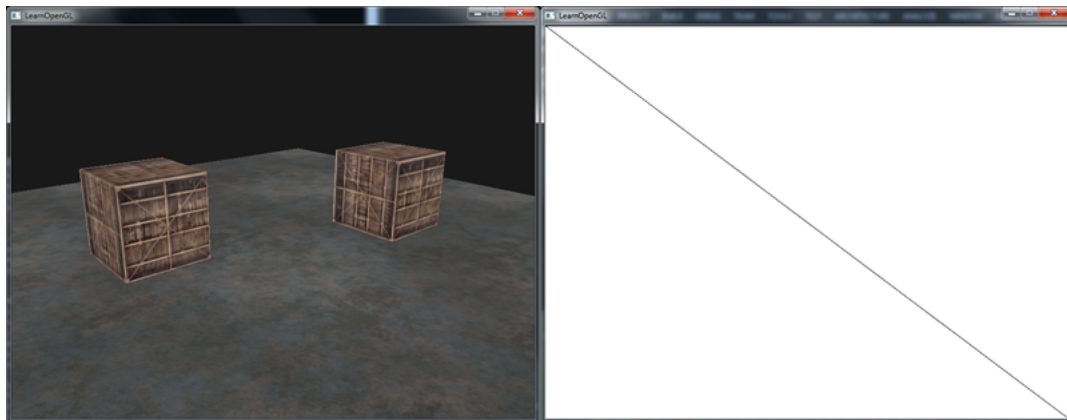

The left shows the visual output which is exactly the same as we've seen in the [depth testing](#) tutorial, but this time, rendered to a simple quad. If we render the scene in wireframe it becomes obvious we've only drawn a single quad in the default framebuffer.

You can find the source code of the application [here](#).

So what was the use of this again? Because we can now freely access each of the pixels of the completely rendered scene as a single texture image, we can create some interesting effects in the fragment shader. The combination of all these interesting effects are called [post-processing](#) effects.

26.3 Post-processing

Now that the entire scene is rendered to a single texture we can create some interesting effects simply by manipulating the texture data. In this section we'll show you some of the more popular post-processing effects and how you might create your own with some added creativity.

Let's start with one of the simplest post-processing effects.

26.3.1 Inversion

We have access to each of the colors of the render output so it's not so hard to return the inverse of these colors in the fragment shader. We're taking the color of the screen texture and inverse it by subtracting it from `1.0`:

```
void main()
{
    color = vec4(vec3(1.0 - texture(screenTexture, TexCoords)), 1.0);
}
```

While inversion is a relatively simple post-processing effect it already creates funky results:

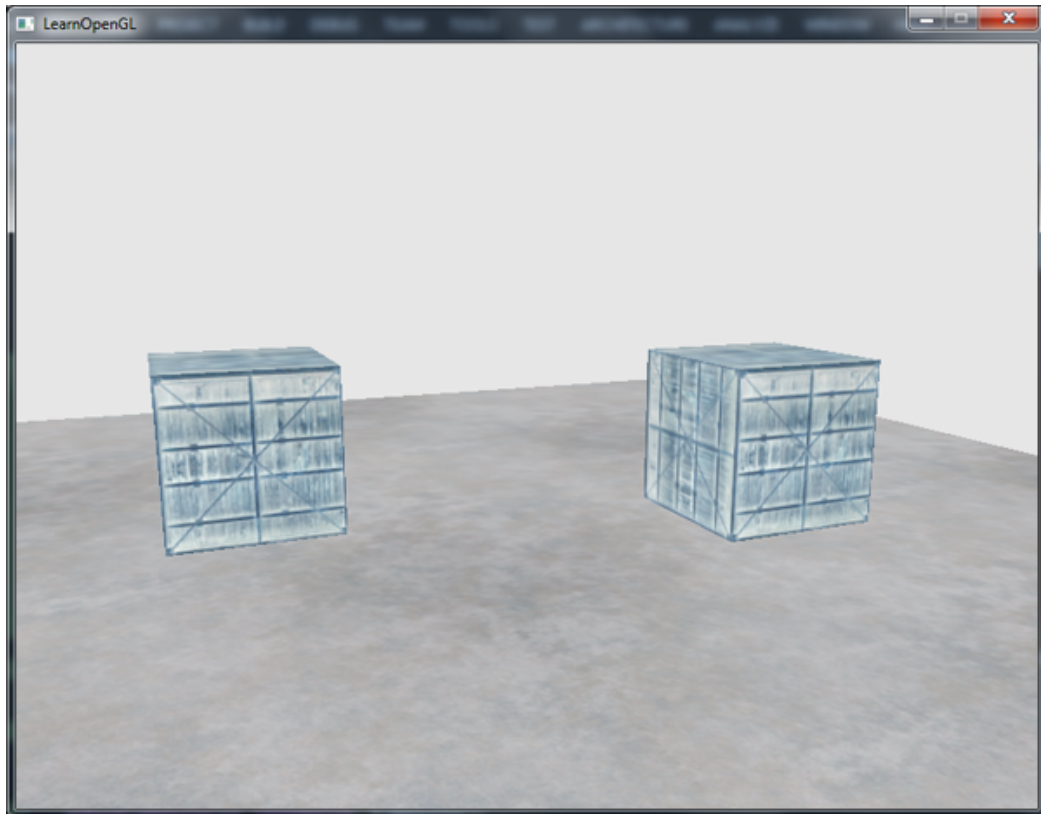

The entire scene now has all its colors inverted with a single line of code in the fragment shader. Pretty cool huh?

26.3.2 Grayscale

Another interesting effect is to remove all colors from the scene except the white, gray and black colors effectively grayscaling the entire image. An easy way to do this is simply by taking all the color components and averaging their results:

```
void main()
{
    color = texture(screenTexture, TexCoords);
    float average = (color.r + color.g + color.b) / 3.0;
    color = vec4(average, average, average, 1.0);
}
```

This already creates pretty good results, but the human eye tends to be more sensitive to green colors and the least to blue, so to get the most physically accurate results we'll need to use weighted channels:

```
void main()
{
    color = texture(screenTexture, TexCoords);
    float average = 0.2126 * color.r + 0.7152 * color.g + 0.0722 * color.b;
    color = vec4(average, average, average, 1.0);
}
```

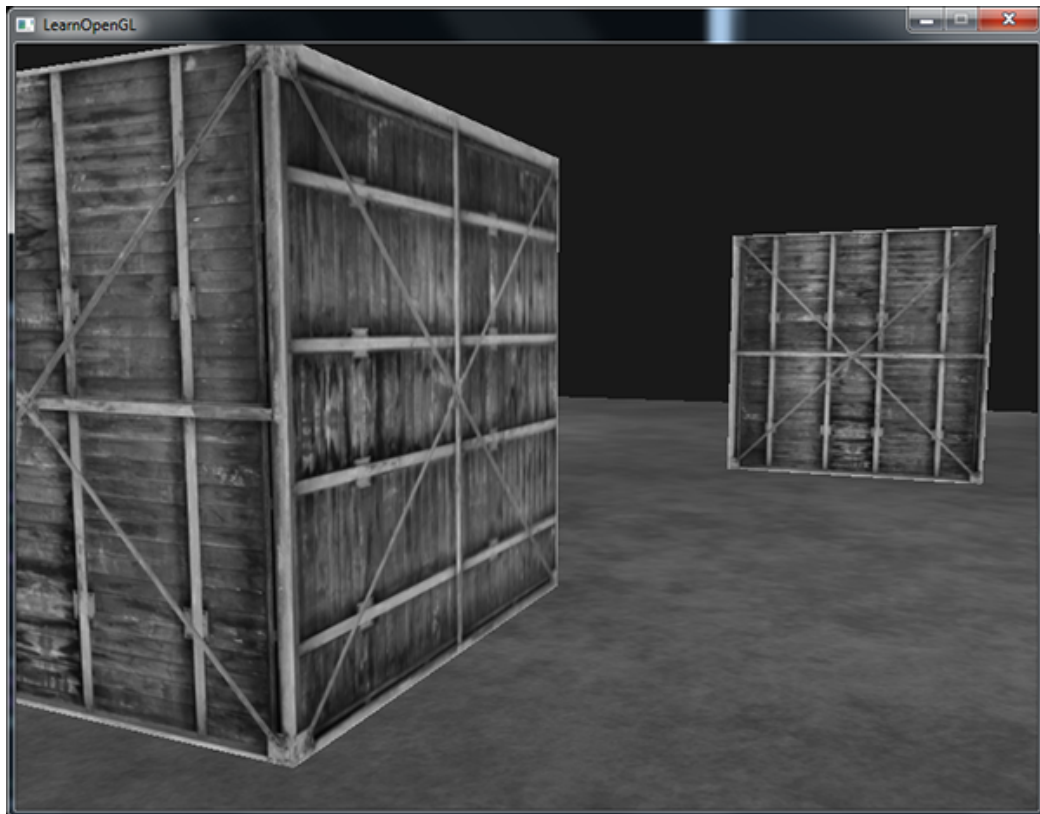

You probably won't notice the difference right away, but with more complicated scenes, such a weighted grayscaling effect tends to be more realistic.

26.4 Kernel effects

Another advantage about doing post-processing on a single texture image is that we can actually sample color values from other parts of the texture. We could for example take a small area around the current texture coordinate and sample multiple texture values around the current texture value. We can then create interesting effects by combining them in creative ways.

A **kernel** (or convolution matrix) is a small matrix-like array of values centered on the current pixel that multiplies surrounding pixel values by its kernel values and adds them all together to form a single value. So basically we're adding a small offset to the texture coordinates in surrounding directions of the current pixel and combine the results based on the kernel. An example of a kernel is given below:

$$\begin{bmatrix} 2 & 2 & 2 \\ 2 & -15 & 2 \\ 2 & 2 & 2 \end{bmatrix}$$

This kernel takes 8 surrounding pixel values and multiplies them by 2 and the current pixel by -15. This example kernel basically multiplies the surrounding pixels by a weight determined in the kernel and balances the result by multiplying the current pixel by a large negative weight.

Most kernels you'll find over the internet all sum up to 1 if you add all the weights together. If they don't add up to 1 it means that the resulting texture color ends brighter or darker than the original texture value.

Kernels are an extremely useful tool for post-processing since they're quite easy to use, experiment with and a lot of examples can be found online. We do have to slightly adapt the fragment shader a bit to actually support kernels. We make the assumption that each kernel we'll be using is a 3x3 kernel (which most kernels are):

```
const float offset = 1.0 / 300;

void main()
{
    vec2 offsets[9] = vec2[](
        vec2(-offset, offset), // top-left
        vec2(0.0f,    offset), // top-center
        vec2(offset,  offset), // top-right
        vec2(-offset, 0.0f),   // center-left
        vec2(0.0f,    0.0f),   // center-center
        vec2(offset,  0.0f),   // center-right
        vec2(-offset, -offset), // bottom-left
        vec2(0.0f,   -offset), // bottom-center
        vec2(offset, -offset)  // bottom-right
    );

    float kernel[9] = float[](
        -1, -1, -1,
        -1, 9, -1,
        -1, -1, -1
    );

    vec3 sampleTex[9];
    for(int i = 0; i < 9; i++)
    {
        sampleTex[i] = vec3(texture(screenTexture, TexCoords.st + offsets[i]
    ));
    }
    vec3 col;
    for(int i = 0; i < 9; i++)
        col += sampleTex[i] * kernel[i];

    color = vec4(col, 1.0);
}
```

In the fragment shader we first create an array of 9 `vec2` offsets for each surrounding texture coordinate. The offset is simply a constant value that you could customize to your liking. Then

we define the kernel, which in this case is a **sharpen** kernel that sharpens each color value by sampling all surrounding pixels in an interesting way. Lastly, we add each offset to the current texture coordinate when sampling and then multiply these texture values with the weighted kernel values that we add together.

This particular sharpen kernel looks like this:

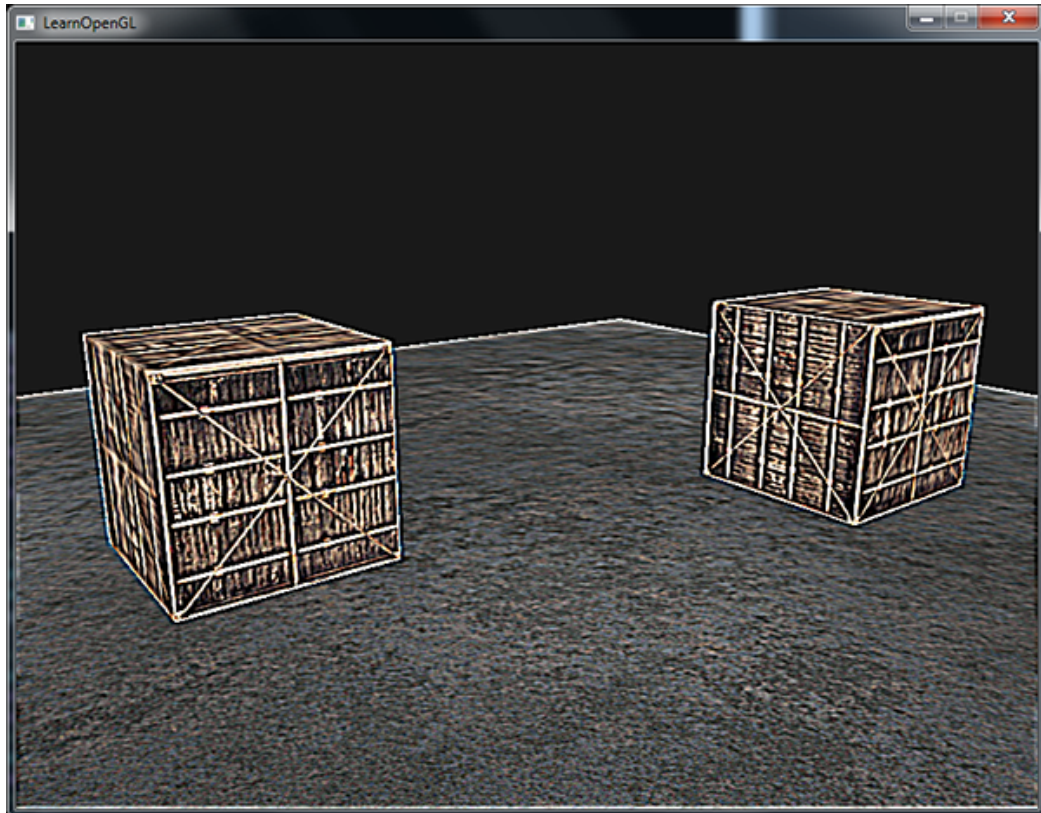

This could create some interesting effects of where your player might be on a narcotic adventure.

26.4.1 Blur

A kernel that creates a **blur** effect is defined as follows:

$$\begin{bmatrix} 1 & 2 & 1 \\ 2 & 4 & 2 \\ 1 & 2 & 1 \end{bmatrix} / 16$$

Because all values add up to 16, simply returning the combined sampled colors would result in an extremely bright color so we have to divide each value of the kernel by 16. The resulting kernel array would then become:

```
float kernel[9] = float[ ] (
    1.0 / 16, 2.0 / 16, 1.0 / 16,
    2.0 / 16, 4.0 / 16, 2.0 / 16,
```

```
1.0 / 16, 2.0 / 16, 1.0 / 16  
);
```

By changing the kernel `float` array in the fragment shader we're completely changing the post-processing effect we're after. It now looks something like this:

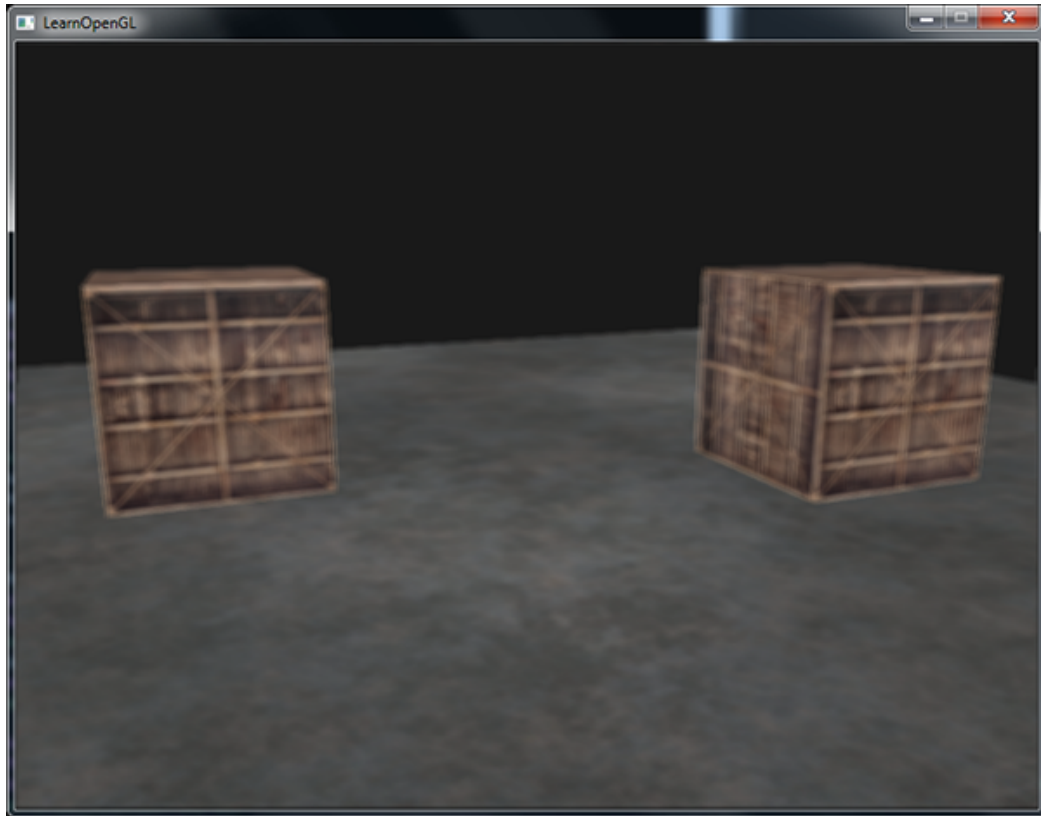

Such a blur effect creates interesting possibilities. We could vary the blur amount over time for example to create the effect of someone being drunk, or increase the blur whenever the main character is not wearing glasses. Blurring also give us a useful utility to smooth color values which we will use in later tutorials.

You can see that once we have such a little kernel implementation in place it is quite easy to create cool post-processing effects. Let's show you a last popular effect to finish this discussion.

26.4.2 Edge detection

Below you can find an `edge-detection` kernel that is similar to the sharpen kernel:

$$\begin{bmatrix} 1 & 1 & 1 \\ 1 & -8 & 1 \\ 1 & 1 & 1 \end{bmatrix}$$

This kernel highlights all edges and darkens the rest, which is quite useful when we only care about edges in an image.

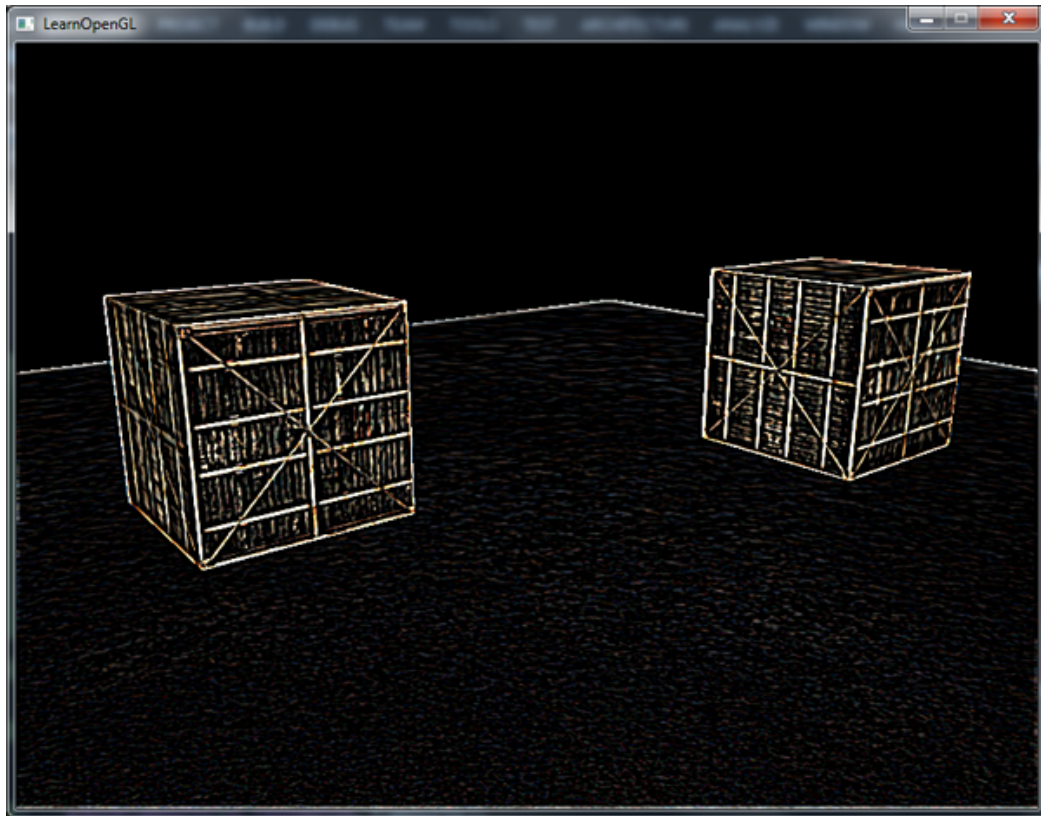

It probably does not come as a surprise that kernels like this are used as image-manipulating tools/filters in tools like Photoshop. Because of a graphic card's ability to process fragments with extreme parallel capabilities, we can manipulate images on a per-pixel basis in real-time with relative ease. Image-editing tools therefore tend to use graphics cards more often for image-processing.

26.5 Exercises

- Can you use framebuffer to create a rear-view mirror? For this you'll have to draw your scene twice: one with the camera rotated 180 degrees and the other as normal. Try to create a small quad on the top of your screen to apply the mirror texture on: [solution](#) and [visual result](#).
- Play around with the kernel values and create your own interesting post-processing effects. Try searching the internet as well for other interesting kernels.

27. Cubemaps

We've been using 2D textures for a while now, but there are even more texture types we haven't explored yet and in this tutorial we'll discuss a texture type that is actually a combination of multiple textures mapped into a single texture: a **cube map**.

A cubemap is basically a texture that contains 6 individual 2D textures that each form one side of a cube: a textured cube. You might be wondering what's the point of such a cube? Why bother with combining 6 individual textures into a single entity instead of just using 6 individual textures? Well, cube maps have the useful property that they can be indexed/sampled using a direction vector. Imagine we have a $1 \times 1 \times 1$ unit cube with the origin of a direction vector residing at its center. Sampling a texture value from the cube map with an orange direction vector looks a bit like this:

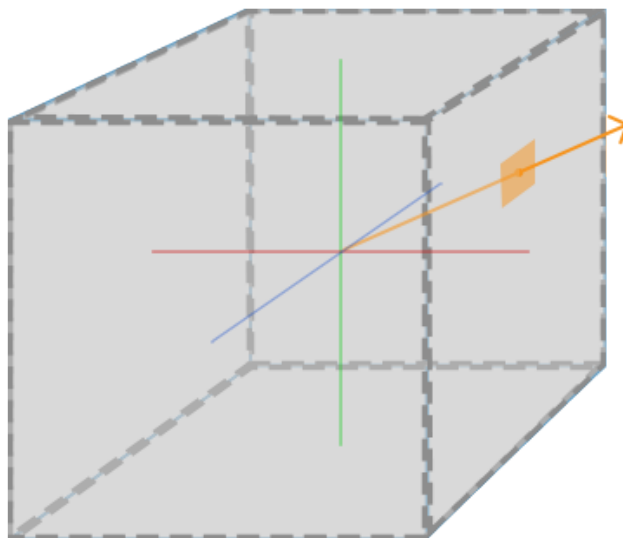

The magnitude of the direction vector doesn't matter. As long as a direction is supplied, OpenGL retrieves the corresponding texels that the direction hits (eventually) and returns the properly sampled texture value.

If we imagine we have a cube shape that we attach such a cubemap to, the direction vector to sample the cubemap would be similar to the (interpolated) vertex position of the cube. This way we can sample the cubemap using the cube's actual position vectors as long as the cube is centered on the origin. We can then retrieve the texture coordinates of all vertices as the vertex positions of the cube. The result is a texture coordinate that accesses the proper individual *face* texture of the cubemap.

27.1 Creating a cubemap

A cubemap is a texture like any other texture so to create one we generate a texture and bind it to the proper texture target before we do any further texture operations. This time binding to `GL_TEXTURE_CUBE_MAP`:

```
GLuint textureID;
glGenTextures(1, &textureID);
glBindTexture(GL_TEXTURE_CUBE_MAP, textureID);
```

Because a cubemap consists of 6 textures, one for each face, we have to call `glTexImage2D` six times with their parameters set to values similar to the previous tutorials. This time however, we have to set the texture *target* parameter to a specific face of the cubemap, basically telling OpenGL which side of the cubemap we're creating a texture for. This means we have to call `glTexImage2D` once for each face of the cubemap.

Since we have 6 faces OpenGL provides us with 6 special texture targets specifically for targeting a face of the cubemap:

Texture target	Orientation
<code>GL_TEXTURE_CUBE_MAP_POSITIVE_X</code>	Right
<code>GL_TEXTURE_CUBE_MAP_NEGATIVE_X</code>	Left
<code>GL_TEXTURE_CUBE_MAP_POSITIVE_Y</code>	Top
<code>GL_TEXTURE_CUBE_MAP_NEGATIVE_Y</code>	Bottom
<code>GL_TEXTURE_CUBE_MAP_POSITIVE_Z</code>	Back
<code>GL_TEXTURE_CUBE_MAP_NEGATIVE_Z</code>	Front

Like many of OpenGL's enums, their behind-the-scenes `int` value is linearly incremented so if we were to have an array or vector of texture locations we could loop over them by starting with `GL_TEXTURE_CUBE_MAP_POSITIVE_X` and incrementing the enum by 1 each iteration, effectively looping through all the texture targets:

```
int width,height;
unsigned char* image;
for(GLuint i = 0; i < textures_faces.size(); i++)
{
```



```

image = SOIL_load_image(textures_faces[i], &width, &height, 0,
SOIL_LOAD_RGB);
glTexImage2D(
    GL_TEXTURE_CUBE_MAP_POSITIVE_X + i,
    0, GL_RGB, width, height, 0, GL_RGB, GL_UNSIGNED_BYTE, image
);
}

```

Here we have a `vector` called `textures_faces` that contain the locations of all the textures required for the cubemap in the order as given in the table. This generates a texture for each face of the currently bound cubemap.

Because a cubemap is a texture like any other texture we will also specify its wrapping and filtering methods:

```

glTexParameteri(GL_TEXTURE_CUBE_MAP, GL_TEXTURE_MAG_FILTER, GL_LINEAR);
glTexParameteri(GL_TEXTURE_CUBE_MAP, GL_TEXTURE_MIN_FILTER, GL_LINEAR);
glTexParameteri(GL_TEXTURE_CUBE_MAP, GL_TEXTURE_WRAP_S, GL_CLAMP_TO_EDGE);
glTexParameteri(GL_TEXTURE_CUBE_MAP, GL_TEXTURE_WRAP_T, GL_CLAMP_TO_EDGE);
glTexParameteri(GL_TEXTURE_CUBE_MAP, GL_TEXTURE_WRAP_R, GL_CLAMP_TO_EDGE);

```

Don't be scared by the `GL_TEXTURE_WRAP_R`, this simply sets the wrapping method for the texture's R coordinate which corresponds to the texture's 3rd dimension (like the z for positions). We set the wrapping method to `GL_CLAMP_TO_EDGE` since texture coordinates that are exactly between two faces might not hit an exact face (due to some hardware limitations) so by using `GL_CLAMP_TO_EDGE` OpenGL always return their edge values whenever we sample between faces.

Then before drawing the objects that will use the cubemap, we activate the corresponding texture unit and bind the cubemap before rendering, not much of a difference compared to normal 2D textures.

Within the fragment shader we also have to use a different sampler of the type `samplerCube` that we sample from using the `texture` function, but this time using a `vec3` direction vector instead of a `vec2`. An example of fragment shader using a cubemap looks like this:

```

in vec3 textureDir; // Direction vector representing a 3D texture
coordinate
uniform samplerCube cubemap; // Cubemap texture sampler

void main()
{
    color = texture(cubemap, textureDir);
}

```

That is still great and all, but why bother? Well, it just so happens that there are quite a few interesting techniques that are a lot easier to implement with a cubemap. One of those techniques is creating a `skybox`.

27.2 Skybox

A skybox is a (large) cube that encompasses the entire scene and contains 6 images of a surrounding environment, giving the player the illusion that the environment he's in is actually much larger than

it actually is. Some examples of skyboxes used in videogames are images of mountains, of clouds or of a starry night sky. An example of a skybox, using starry night sky images, can be seen in the following screenshot of the third elder scrolls game:



You probably guessed by now that skyboxes like this suit cubemaps perfectly: we have a cube that has 6 faces and needs to be textured per face. In the previous image they used several images of a night sky to give the illusion the player is in some large universe while he's actually inside a tiny little box.

There are usually enough resources online where you could find skyboxes like these. This [website](#) for example has plenty of skyboxes. These skybox images usually have the following pattern:

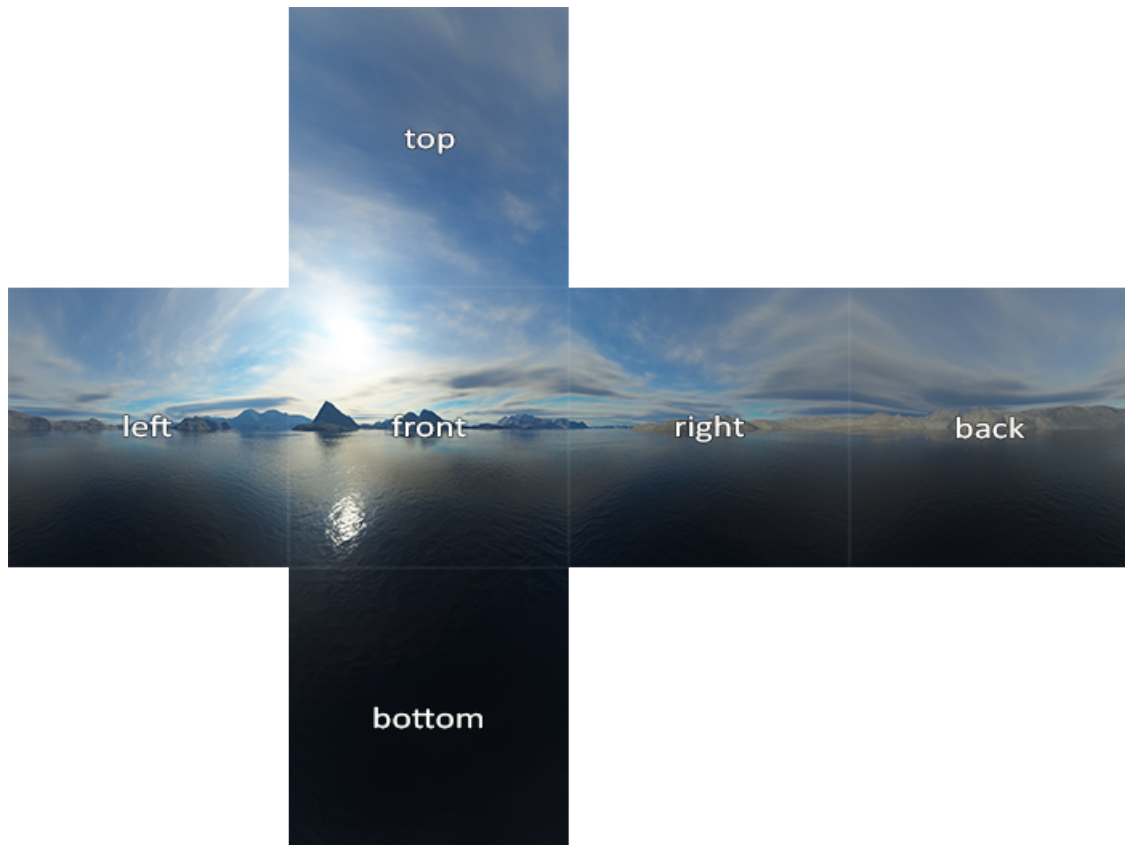

If you would fold those 6 sides into a cube you'd get the completely textured cube that simulates a large landscape. Some resources provide the skyboxes in a format like this in which case you'd have to manually extract the 6 face images, but in most cases they're provided as 6 single texture images.

This particular (high-quality) skybox is what we'll use for our scene and can be downloaded [here](#).

27.3 Loading a skybox

Since a skybox is by itself just a cubemap, loading a skybox isn't too different from what we've seen before. To load the skybox we're going to use the following function that accepts a `vector` of 6 texture locations:

```
GLuint loadCubemap(vector<const GLchar*> faces)
{
    GLuint textureID;
    glGenTextures(1, &textureID);
    glActiveTexture(GL_TEXTURE0);

    int width,height;
    unsigned char* image;

    glBindTexture(GL_TEXTURE_CUBE_MAP, textureID);
    for(GLuint i = 0; i < faces.size(); i++)
    {
```



```

        image = SOIL_load_image(faces[i], &width, &height, 0, SOIL_LOAD_RGB
    );
    glTexImage2D(
        GL_TEXTURE_CUBE_MAP_POSITIVE_X + i, 0,
        GL_RGB, width, height, 0, GL_RGB, GL_UNSIGNED_BYTE, image
    );
}
glTexParameteri(GL_TEXTURE_CUBE_MAP, GL_TEXTURE_MAG_FILTER, GL_LINEAR);
glTexParameteri(GL_TEXTURE_CUBE_MAP, GL_TEXTURE_MIN_FILTER, GL_LINEAR);
glTexParameteri(GL_TEXTURE_CUBE_MAP, GL_TEXTURE_WRAP_S,
GL_CLAMP_TO_EDGE);
glTexParameteri(GL_TEXTURE_CUBE_MAP, GL_TEXTURE_WRAP_T,
GL_CLAMP_TO_EDGE);
glTexParameteri(GL_TEXTURE_CUBE_MAP, GL_TEXTURE_WRAP_R,
GL_CLAMP_TO_EDGE);
glBindTexture(GL_TEXTURE_CUBE_MAP, 0);

return textureID;
}

```

The function itself shouldn't be too surprising. It is basically all the cubemap code we've seen in the previous section, but combined in a single manageable function.

Then before we call this function we'll load the appropriate texture paths in a vector in the order as specified by the cubemap enums:

```

vector<const GLchar*> faces;
faces.push_back("right.jpg");
faces.push_back("left.jpg");
faces.push_back("top.jpg");
faces.push_back("bottom.jpg");
faces.push_back("back.jpg");
faces.push_back("front.jpg");
GLuint cubemapTexture = loadCubemap(faces);

```

We now loaded the skybox as a cubemap with `cubemapTexture` as its id. We can now bind it to a cube to finally replace the lame clear color we've been using as the background all this time.

27.4 Displaying a skybox

Because a skybox is drawn on a cube we'll need another VAO, VBO and a fresh set of vertices like any other object. You can get its vertex data [here](#).

A cubemap used to texture a 3D cube can be sampled using the positions of the cube as the texture coordinates. When a cube is centered on the origin (0,0,0) each of its position vectors is also a direction vector from the origin. This direction vector is exactly what we need to get the corresponding texture value at that specific cube's position. For this reason we only need to supply position vectors and don't need texture coordinates.

To render the skybox we'll need a new set of shaders which aren't too complicated. Because we only have one vertex attribute the vertex shader is quite simple:

```

#version 330 core

```

```
layout (location = 0) in vec3 position;
out vec3 TexCoords;

uniform mat4 projection;
uniform mat4 view;

void main()
{
    gl_Position = projection * view * vec4(position, 1.0);
    TexCoords = position;
}
```

Note that the interesting part of the vertex shader is that we set the incoming position vectors as the outgoing texture coordinates for the fragment shader. The fragment shader then takes these as input to sample a `samplerCube`:

```
#version 330 core
in vec3 TexCoords;
out vec4 color;

uniform samplerCube skybox;

void main()
{
    color = texture(skybox, TexCoords);
}
```

The fragment shader is all relatively straightforward. We take the vertex attribute's position vectors as the texture's direction vector and use those to sample the texture values from the cubemap.

Rendering the skybox is easy now that we have a cubemap texture, we simply bind the cubemap texture and the `skybox` sampler is automatically filled with the skybox cubemap. To draw the skybox we're going to draw it as the first object in the scene and disable depth writing. This way the skybox will always be drawn at the background of all the other objects.

```
glDepthMask(GL_FALSE);
skyboxShader.Use();
// ... Set view and projection matrix
glBindVertexArray(skyboxVAO);
glBindTexture(GL_TEXTURE_CUBE_MAP, cubemapTexture);
glDrawArrays(GL_TRIANGLES, 0, 36);
glBindVertexArray(0);
glDepthMask(GL_TRUE);
// ... Draw rest of the scene
```

If you run this you will get into difficulties though. We want the skybox to be centered around the player so that no matter how far the player moves, the skybox won't get any closer giving the impression the surrounding environment is extremely large. The current view matrix however transforms all the skybox's positions by rotating, scaling and translating them, so if the player moves, the cubemap moves as well! We want to remove the translation part of the view matrix so movement doesn't affect the skybox's position vectors.

You might remember from the [basic lighting](#) tutorial that we could remove the translation

section of transformation matrices by taking the upper-left 3x3 matrix of the 4x4 matrix, effectively removing the translation components. We can achieve this by simply converting the view matrix to a 3x3 matrix (removing translation) and converting it back to a 4x4 matrix:

```
glm::mat4 view = glm::mat4(glm::mat3(camera.GetViewMatrix()));
```

This removes any translation, but keeps all rotation transformations so the user can still look around the scene.

The result is a scene that instantly looks enormous due to our skybox. If you'd fly around the basic container you immediately get a sense of scale which dramatically improves the realism of the scene. The result looks something like this:

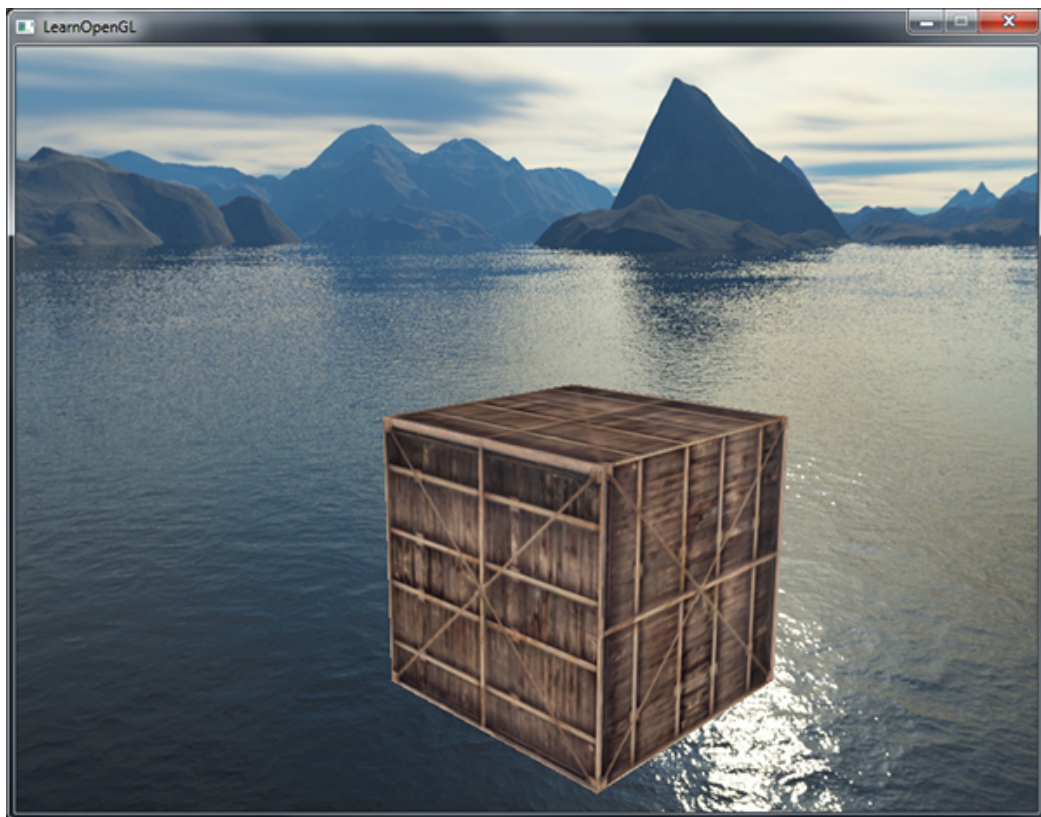

You can find the complete source code [here](#) in case you're stuck or you'd like to compare the source code with your own.

Try experimenting with different skyboxes and see how they can have an enormous impact on the look and feel of your scene.

27.5 An optimization

Right now we've rendered the skybox first before we rendered all the other objects in the scene. This works great, but isn't too efficient. If we render the skybox first we're running the fragment shader for each pixel on the screen even though only a small part of the skybox will eventually be visible; fragments that could have easily been discarded using [early depth testing](#) saving us valuable bandwidth.

So to give us a slight performance boost we're going to render the skybox last. This way, the depth buffer is completely filled with all the objects' depth values so we only have to render the skybox's fragments wherever the early depth test passes, greatly reducing the calls to the fragment shader. The problem is that the skybox will most likely fail to render since it's only a 1x1x1 cube, failing most depth tests. Simply rendering it without depth testing is not a solution since the skybox will then overwrite all the other objects in the scene. We need to trick the depth buffer into believing that the skybox has the maximum depth value of 1.0 so that it fails the depth test wherever there's a different object in front of it.

In the [coordinate systems](#) tutorial we said that *perspective division* is performed after the vertex shader has run, dividing the `gl_Position`'s xyz coordinates by its w component. We also know from the [depth testing](#) tutorial that the z component of the resulting division is equal to that vertex's depth value. Using this information we can set the z component of the output position equal to its w component which will result in a z component that is always equal to 1.0, because when the perspective division is applied its z component translates to $w / w = 1.0$:

```
void main()
{
    vec4 pos = projection * view * vec4(position, 1.0);
    gl_Position = pos.xyww;
    TexCoords = position;
}
```

The resulting *normalized device coordinates* will then always have a z value equal to 1.0: the maximum depth value. The skybox will as a result only be rendered wherever there are no objects visible (only then it will pass the depth test, everything else is in front of the skybox).

We do have to change the depth function a little by setting it to `GL_LEQUAL` instead of the default `GL_LESS`. The depth buffer will be filled with values of 1.0 for the skybox, so we need to make sure the skybox passes the depth tests with values *less than or equal* to the depth buffer instead of *less than*.

You can find the more optimized version of the source code [here](#).

27.6 Environment mapping

We now have the entire surrounding environment mapped in a single texture object and we could use that information for more than just a skybox. Using a cubemap with an environment, we could give objects reflective or refractive properties. Techniques that use an environment cubemap like this are called [environment mapping](#) techniques and the two most popular ones are [reflection](#) and [refraction](#).

27.7 Reflection

Reflection is the property that an object (or part of an object) [reflects](#) its surrounding environment e.g. the object's colors are more or less equal to its environment based on the angle of the viewer. A mirror for example is a reflective object: it reflects its surroundings based on the viewer's angle.

The basics of reflection are not that difficult. The following image shows how we can calculate a **reflection vector** and use that vector to sample from a cubemap:

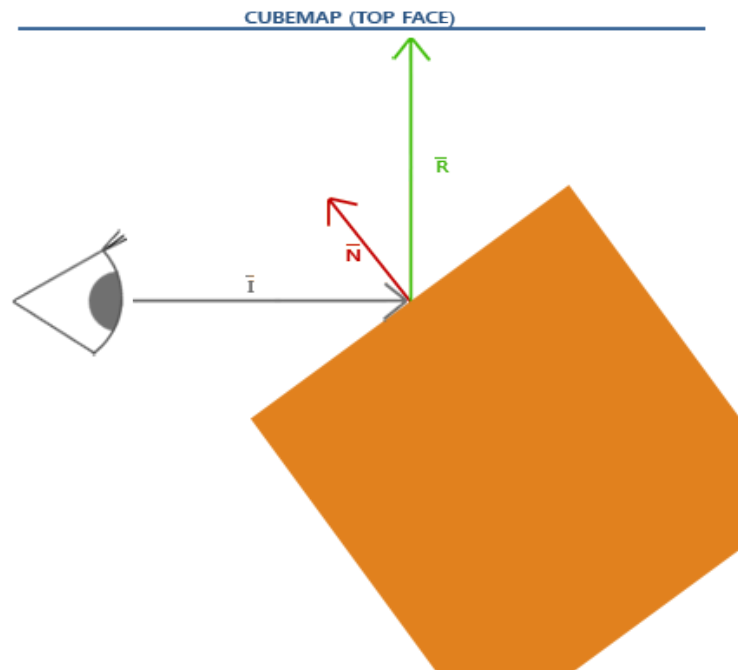

We calculate a reflection vector \bar{R} around the object's normal vector \bar{N} based on the view direction vector \bar{I} . We can calculate this reflection vector using GLSL's built-in `reflect` function. The resulting vector \bar{R} is then used as a direction vector to index/sample the cubemap returning a color value of the environment. The resulting effect is that the object seems to reflect the skybox.

Since we already have a skybox setup in our scene, creating reflections isn't too difficult. We'll change the fragment shader used by the container to give the container reflective properties:

```
#version 330 core
in vec3 Normal;
in vec3 Position;
out vec4 color;

uniform vec3 cameraPos;
uniform samplerCube skybox;

void main()
{
    vec3 I = normalize(Position - cameraPos);
    vec3 R = reflect(I, normalize(Normal));
    color = texture(skybox, R);
}
```

We first calculate the view/camera direction vector I and use this to calculate the reflect vector R which we then use to sample from the skybox cubemap. Note that we have the fragment's interpolated `Normal` and `Position` variable again so we'll need to adjust the vertex shader as well.

```
#version 330 core
```

```
layout (location = 0) in vec3 position;
layout (location = 1) in vec3 normal;

out vec3 Normal;
out vec3 Position;

uniform mat4 model;
uniform mat4 view;
uniform mat4 projection;

void main()
{
    gl_Position = projection * view * model * vec4(position, 1.0f);
    Normal = mat3(transpose(inverse(model))) * normal;
    Position = vec3(model * vec4(position, 1.0f));
}
```

We're using normal vectors so we'll want to transform them with a normal matrix again. The `Position` output vector is a world-space position vector. This `Position` output of the vertex shader is used to calculate the view direction vector in the fragment shader.

Because we're using normals you'll want to update the `vertex data` and update the attribute pointers as well. Also make sure to set the `cameraPos` uniform.

Then we also want to bind the cubemap texture before rendering the container:

```
glBindVertexArray(cubeVAO);
glBindTexture(GL_TEXTURE_CUBE_MAP, skyboxTexture);
glDrawArrays(GL_TRIANGLES, 0, 36);
glBindVertexArray(0);
```

Compiling and running your code gives you a container that acts like a perfect mirror. The surrounding skybox is perfectly reflected on the container:

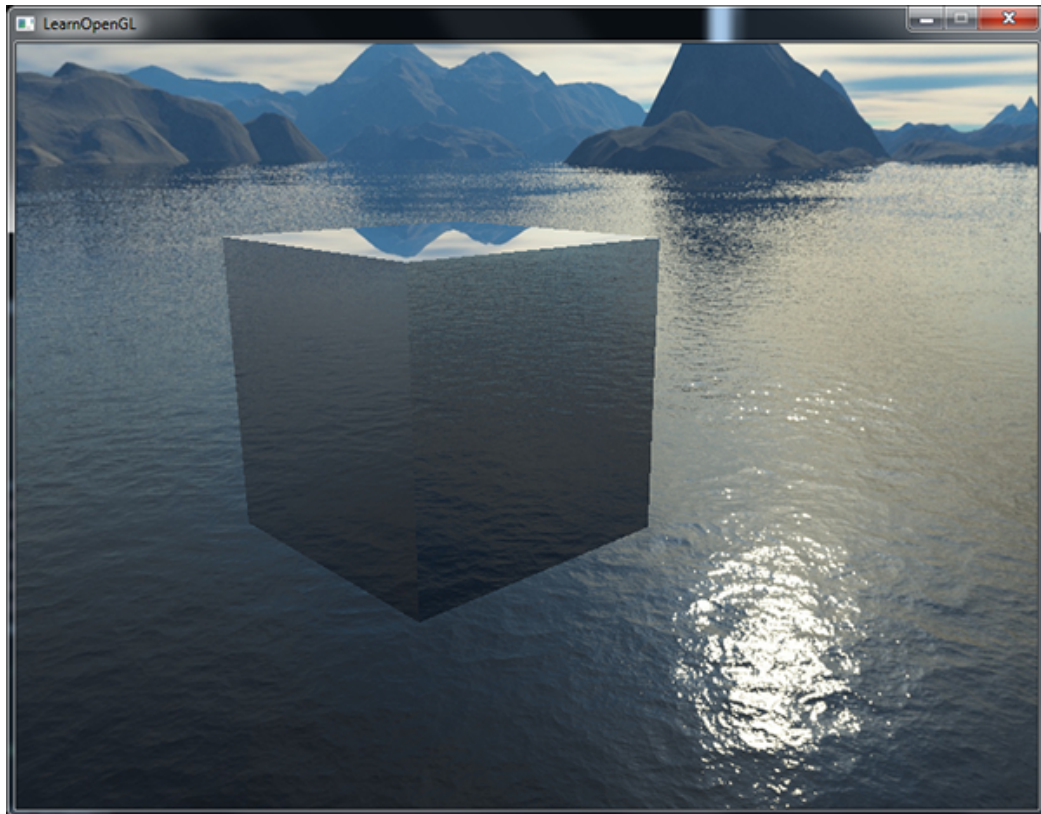

You can find the full source code [here](#).

When reflection is applied to an entire object (like the container) the object looks as if it has a high reflective material like steel or chrome. If we were to load the nanosuit model we used in the [model loading](#) tutorials we'd get the effect that the suit looks to be entirely made out of chrome:



This looks quite awesome, but in reality most models aren't all completely reflective. We could for example introduce **reflection maps** that give the models another extra level of detail. Just like diffuse and specular maps, reflection maps are texture images that we can sample to determine the reflectivity of a fragment. Using these reflection maps we can determine which parts of the model show reflection and by what intensity. In the exercise of this tutorial it's up to you to introduce reflection maps in the model loader we created earlier, significantly boosting the detail of the

nanosuit model.

27.8 Refraction

Another form of environment mapping is called **refraction** and is similar to reflection. Refraction is the change in direction of light due to the change of the material the light flows through. Refraction is what we commonly see with water-like surfaces where the light doesn't enter straight through, but bends a little. It's like looking at your arm when it's halfway in the water.

Refraction is described by **Snell's law** that with environment maps looks a bit like this:

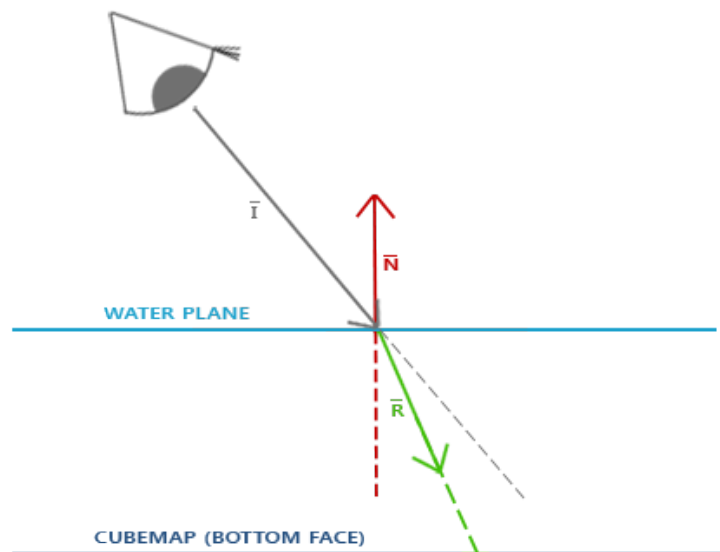

Again, we have a view vector \vec{I} , a normal vector \vec{N} and this time a resulting refraction vector \vec{R} . As you can see, the direction of the view vector is slightly bend. This resulting bended vector \vec{R} is then used to sample from the cubemap.

Refraction can easily be implemented by using GLSL's built-in `refract` function that expects a normal vector, a view direction and a ratio between both materials' **refractive indices**.

The refractive index determines the amount light distorts/bends of a material where each material has its own refractive index. A list of the most common refractive indices are given in the following table:

Material	Refractive index
Air	1.00
Water	1.33
Ice	1.309
Glass	1.52
Diamond	2.42

We use these refractive indices to calculate the ratio between both materials the light passes

through. In our case, the light/view ray goes from *air* to *glass* (if we assume the container is made of glass) so the ratio becomes $\frac{1.00}{1.52} = 0.658$.

We already have the cubemap bound, supplied the vertex data with normals and set the camera position as a uniform. The only thing we have to change is the fragment shader:

```
void main()
{
    float ratio = 1.00 / 1.52;
    vec3 I = normalize(Position - cameraPos);
    vec3 R = refract(I, normalize(Normal), ratio);
    color = texture(skybox, R);
}
```

By changing the refractive indices you can create completely different visual results. Compiling the application and running the results is not so interesting though since we're simply using a basic container, which doesn't really show the effect refraction has aside that it acts slightly as a magnifying glass right now. Using the same shaders on the nanosuit model however does show us the effect we're looking for: a glass-like object.

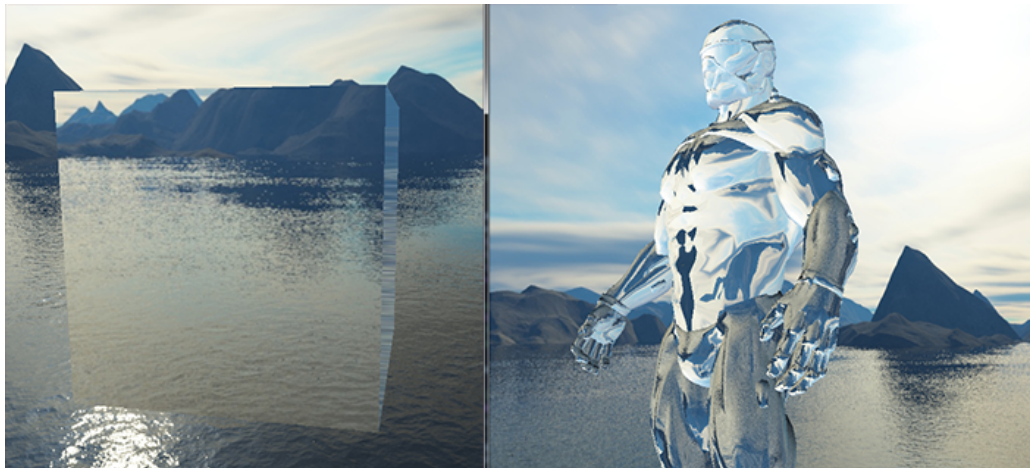

You can imagine that with the right combination of lighting, reflection, refraction and vertex movement you can create pretty neat water graphics. Do note that for physically accurate results we also should refract the light again when it leaves the object; now we simply used single-side refraction which is fine for most purposes.

27.9 Dynamic environment maps

Right now we've been using a static combination of images as the skybox, which looks great, but doesn't include the actual scene with possibly moving objects. We didn't really notice this so far, because we only used a single object. If we had a mirror-like objects with multiple surrounding objects, only the skybox would be visible in the mirror as if it was the only object in the scene.

Using framebuffer it is possible to create a texture of the scene for all 6 different angles from the object in question and store those in a cubemap each render iteration. We can then use this (dynamically generated) cubemap to create realistic reflection and refractive surfaces that include all other objects. This is called **dynamic environment mapping**, because we dynamically create a

cubemap of an object's surroundings and use that as its environment map.

While it looks great, it has one enormous disadvantage: we have to render the scene 6 times per object using an environment map, which is an enormous performance penalty on your application. Modern applications try to use the skybox as much as possible and where possible pre-compile cubemaps wherever they can to still sort-of create dynamic environment maps. While dynamic environment mapping is a great technique, it requires a lot of clever tricks and hacks to get it working in an actual rendering application without too many performance drops.

27.10 Exercises

- Try to introduce reflection maps into the model loader we created in the [model loading](#) tutorials. You can find the upgraded nanosuit model with reflection maps included [here](#). There are a few things to note though:
 - Assimp doesn't really seem to like reflection maps in most object formats so we cheated a little by storing the reflection maps as *ambient maps*. You can then load the reflection maps by specifying `aiTextureType_AMBIENT` as the texture type when loading materials.
 - I sort of hastily created reflection map textures from the specular texture images, so the reflection maps won't map exactly to the model in some places :).
 - Since the model loader by itself already takes up 3 texture units in the shader, you'll have to bind the skybox to a 4th texture unit since we'll also sample from the skybox in the same shader.
- You can find the solution source code [here](#) together with the updated [model](#) and [mesh](#) class. The shaders used for rendering the reflection maps can be found here: [vertex shader](#) and [fragment shader](#). If you did things right it'll look something like [this](#).

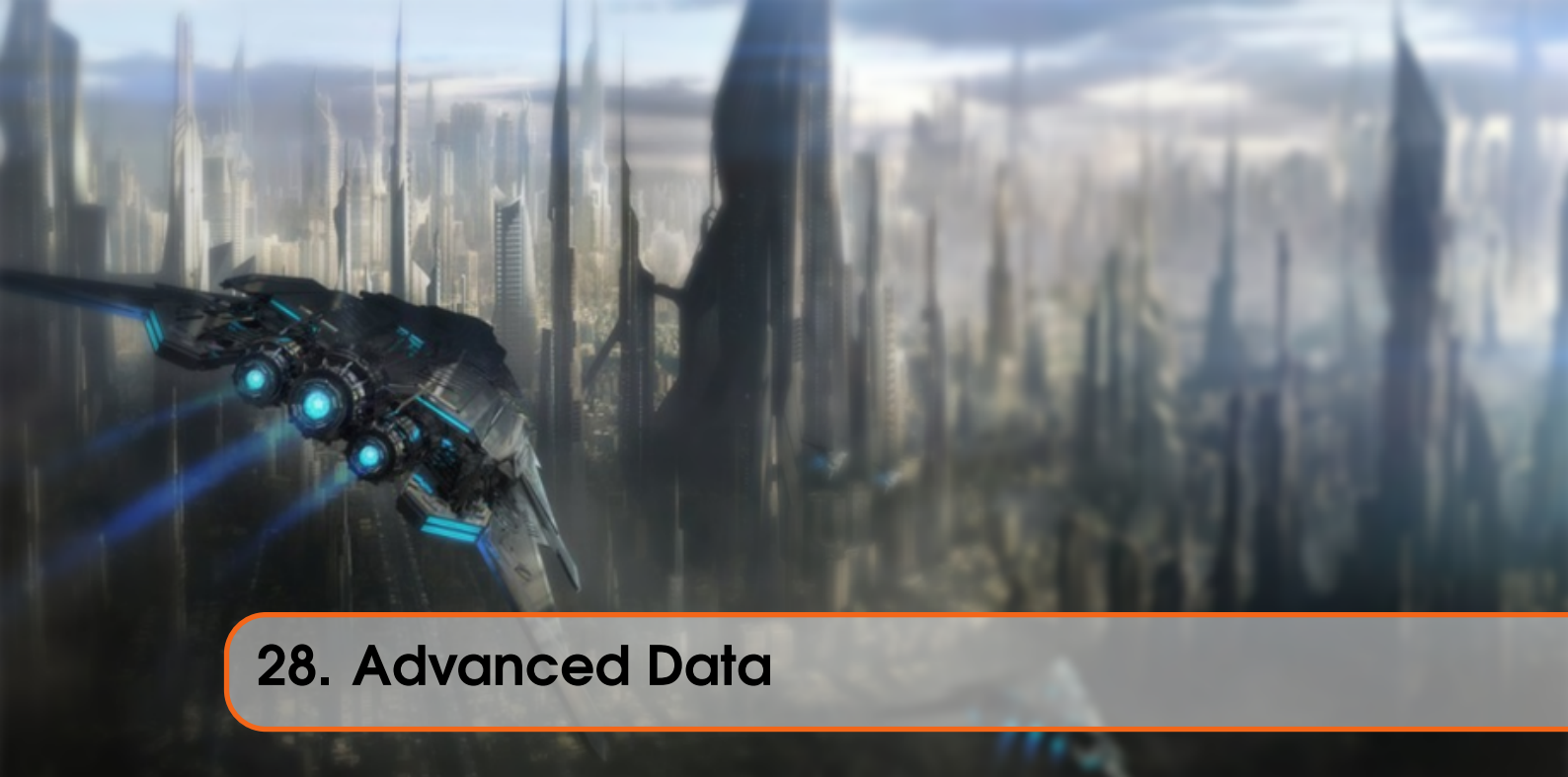

28. Advanced Data

We've been extensively using buffers in OpenGL to store data for quite some time now. There are more interesting ways to manipulate buffers and also other interesting methods to pass large amounts of data to the shaders via textures. This tutorial we'll discuss some more interesting buffer functions and how we can use texture objects to store large amounts of data (the texture part of the tutorial has not yet been written).

A buffer in OpenGL is only an object that manages a certain piece of memory and nothing more. We give a meaning to a buffer when binding it to a specific **buffer target**. A buffer is only a vertex array buffer when we bind it to `GL_ARRAY_BUFFER`, but we could just as easily bind it to `GL_ELEMENT_ARRAY_BUFFER`. OpenGL internally stores a buffer per target and based on the target, processes the buffers differently.

So far we've been filling the memory managed by the buffer objects by calling `glBufferData` which allocates a piece of memory and adds data into this memory. If we were to pass `NULL` as its data argument, the function would only allocate memory and not fill it. This is useful if we first want to *reserve* a specific amount of memory and later come back to this buffer to fill it piece by piece.

Instead of filling the entire buffer with one function call we can also fill specific regions of the buffer by calling `glBufferSubData`. This function expects a buffer target, an offset, the size of the data and the actual data as its arguments. What's new with this function is that we can now give an offset that specifies from *where* we want to fill the buffer. This allows us to insert/update only certain parts of the buffer's memory. Do note that the buffer should have enough allocated memory so a call to `glBufferData` is necessary before calling `glBufferSubData` on the buffer.

```
glBufferSubData(GL_ARRAY_BUFFER, 24, sizeof(data), &data); // Range: [24,  
24 + sizeof(data)]
```

Yet another method for getting data into a buffer is to ask for a pointer to the buffer's memory and directly copy the data to the buffer by yourself. By calling `glMapBuffer` OpenGL returns a pointer to the currently bound buffer's memory for us to operate on:

```
float data[] = {
    0.5f, 1.0f, -0.35f
    ...
};
glBindBuffer(GL_ARRAY_BUFFER, buffer);
// Get pointer
void* ptr = glMapBuffer(GL_ARRAY_BUFFER, GL_WRITE_ONLY);
// Now copy data into memory
memcpy(ptr, data, sizeof(data));
// Make sure to tell OpenGL we're done with the pointer
glUnmapBuffer(GL_ARRAY_BUFFER);
```

By telling OpenGL we're finished with the pointer operations via `glUnmapBuffer` OpenGL knows you're done. By unmapping, the pointer becomes invalid and the function returns `GL_TRUE` if OpenGL was able to map your data successfully to the buffer.

Using `glMapBuffer` is useful to directly map data to a buffer, without first storing it in temporary memory. Think of directly reading data from file and copying into the buffer's memory.

28.1 Batching vertex attributes

Using `glVertexAttribPointer` we were able to specify the attribute layout of the vertex array buffer's content. Within the vertex array buffer we `interleaved` the attributes; that is, we placed the position, normal and/or texture coordinates next to each other for each vertex. Now that we know a bit more about buffers we could take a different approach.

What we could also do is batch all the vector data into large chunks per attribute type instead of interleaving them. Instead of an interleaved layout 123123123123 we take a batched approach 111122223333.

When loading vertex data from file you generally retrieve an array of positions, an array of normals and/or an array of texture coordinates. It might cost some effort to combine these arrays into one large array of interleaved data. Taking the batching approach is then an easier solution that we can easily implement using `glBufferSubData`:

```
GLfloat positions[] = { ... };
GLfloat normals[] = { ... };
GLfloat tex[] = { ... };
// Fill buffer
glBufferSubData(GL_ARRAY_BUFFER, 0, sizeof(positions), &positions);
glBufferSubData(GL_ARRAY_BUFFER, sizeof(positions), sizeof(normals), &
    normals);
glBufferSubData(GL_ARRAY_BUFFER, sizeof(positions) + sizeof(normals),
    sizeof(tex), &tex);
```

This way we can directly transfer the attribute arrays as a whole into the buffer without first having to process them. We could have also combined them in one large array and fill the buffer

right away using `glBufferData`, but using `glBufferSubData` lends itself perfectly for tasks like these.

We'll also have to update the vertex attribute pointers to reflect these changes:

```
glVertexAttribPointer(0, 3, GL_FLOAT, GL_FALSE, 3 * sizeof(GLfloat), 0);
glVertexAttribPointer(1, 3, GL_FLOAT, GL_FALSE, 3 * sizeof(GLfloat), (
    GLvoid*) (sizeof(positions)));
glVertexAttribPointer(
    2, 2, GL_FLOAT, GL_FALSE, 2 * sizeof(GLfloat), (GLvoid*) (sizeof(positions)
    + sizeof(normals)));
```

Note that the `stride` parameter is equal to the size of the vertex attribute, since the next vertex attribute vector can be found directly after its 3 (or 2) components.

This gives us yet another approach of setting and specifying vertex attributes. Using either approach has no immediate benefit to OpenGL, it is mostly a more organized way to set vertex attributes. The approach you want to use is purely based on your preference and the type of application.

28.2 Copying buffers

Once your buffers are filled with your data you could want to share that data with other buffers or perhaps copy the buffer's content into another buffer. The function `glCopyBufferSubData` allows us to copy the data from one buffer to another buffer with relative ease. The function's prototype is as follows:

```
void glCopyBufferSubData(GLenum readtarget, GLenum writetarget, GLintptr
    readoffset,
    GLintptr writeoffset, GLsizei size);
```

The `readtarget` and `writetarget` parameters expect to give the buffer targets that we want to copy from and to. We could for example copy from a `VERTEX_ARRAY_BUFFER` buffer to a `VERTEX_ELEMENT_ARRAY_BUFFER` buffer by specifying those buffer targets as the read and write targets respectively. The buffers currently bound to those buffer targets will then be affected.

But what if we wanted to read and write data into two different buffers that are both vertex array buffers? We can't bind two buffers at the same time to the same buffer target. For this reason, and this reason alone, OpenGL gives us two more buffer targets called `GL_COPY_READ_BUFFER` and `GL_COPY_WRITE_BUFFER`. We then bind the buffers of our choice to these new buffer targets and set those targets as the `readtarget` and `writetarget` argument.

`glCopyBufferSubData` then reads data of a given size from a given `readoffset` and writes it into the `writetarget` buffer at `writeoffset`. An example of copying the content of two vertex array buffers is shown below:

```
GLfloat vertexData[] = { ... };
glBindBuffer(GL_COPY_READ_BUFFER, vbo1);
glBindBuffer(GL_COPY_WRITE_BUFFER, vbo2);
```

```
glCopyBufferSubData(GL_COPY_READ_BUFFER, GL_COPY_WRITE_BUFFER, 0, 0, sizeof  
    (vertexData));
```

We could've also done this by only binding the `writetarget` buffer to one of the new buffer target types:

```
GLfloat vertexData[] = { ... };  
glBindBuffer(GL_ARRAY_BUFFER, vbo1);  
glBindBuffer(GL_COPY_WRITE_BUFFER, vbo2);  
glCopyBufferSubData(GL_ARRAY_BUFFER, GL_COPY_WRITE_BUFFER, 0, 0, sizeof(  
    vertexData));
```

With some extra knowledge about how to manipulate buffers we can already use them in more interesting ways. The further you get in OpenGL the more useful these new buffer methods start to become. In the [next](#) tutorial where we'll discuss [uniform buffer objects](#) we'll make good use of `glBufferSubData`.

A futuristic cityscape with a flying vehicle in the foreground. The city is filled with tall, slender buildings and a flying vehicle with blue lights is visible in the sky. The scene is set against a backdrop of a cloudy sky.

29. Advanced GLSL

This tutorial won't really show you super advanced cool new features that give an enormous boost to your scene's visual quality. This tutorial goes more or less into some interesting aspects of GLSL and some nice tricks that might help you in your future endeavors. Basically some *good to knows* and *features that might make your life easier* when creating OpenGL applications in combination with GLSL.

We'll discuss some interesting **built-in variables**, new ways to organize shader's input and output and a very useful tool called **uniform buffer objects**.

29.1 GLSL's built-in variables

Shaders are minimal, if we need data from any other source outside the current shader we'll have to pass data around. We learned to do this via vertex attributes, uniforms and samplers. There are however a few extra variables defined by GLSL prefixed with `gl_` that give us an extra means to gather and/or write data. We've already seen two of them in the tutorials so far: `gl_Position` that is the output vector of the vertex shader and the fragment shader's `gl_FragCoord`.

We'll discuss a few interesting built-in input and output variables that are built-in in GLSL and explain how they might benefit us. Note that we won't discuss all built-in variables that exist in GLSL so if you want to see all built-in variables you can check OpenGL's [wiki](#).

29.2 Vertex shader variables

We've already seen `gl_Position` which is the clip-space output position vector of the vertex shader. Setting `gl_Position` in the vertex shader is a strict requirement if you want to render anything on the screen. Nothing we haven't seen before.

29.2.1 gl_PointSize

One of the render primitives we're able to choose from is `GL_POINTS` in which case each single vertex is a primitive and rendered as a point. It is possible to set the size of the points being rendered via OpenGL's `glPointSize` function, but we can also influence this value in the vertex shader.

An output variable defined by GLSL is called `gl_PointSize` that is a `float` variable where you can set the point's width and height in pixels. By describing the point's size in the vertex shader you can influence this point value per vertex.

Influencing the point sizes in the vertex shader is disabled by default, but if you want to enable this you'll have to enable OpenGL's `GL_PROGRAM_POINT_SIZE`:

```
glEnable(GL_PROGRAM_POINT_SIZE);
```

A simple example of influencing the point sizes is by setting the point size equal to the clip-space position's z value which is equal to the vertex's distance to the viewer. The point size should then increase the further we are from the vertices as the viewer.

```
void main()
{
    gl_Position = projection * view * model * vec4(position, 1.0f);
    gl_PointSize = gl_Position.z;
}
```

The result is that the points we've drawn are rendered larger the more we move away from them:

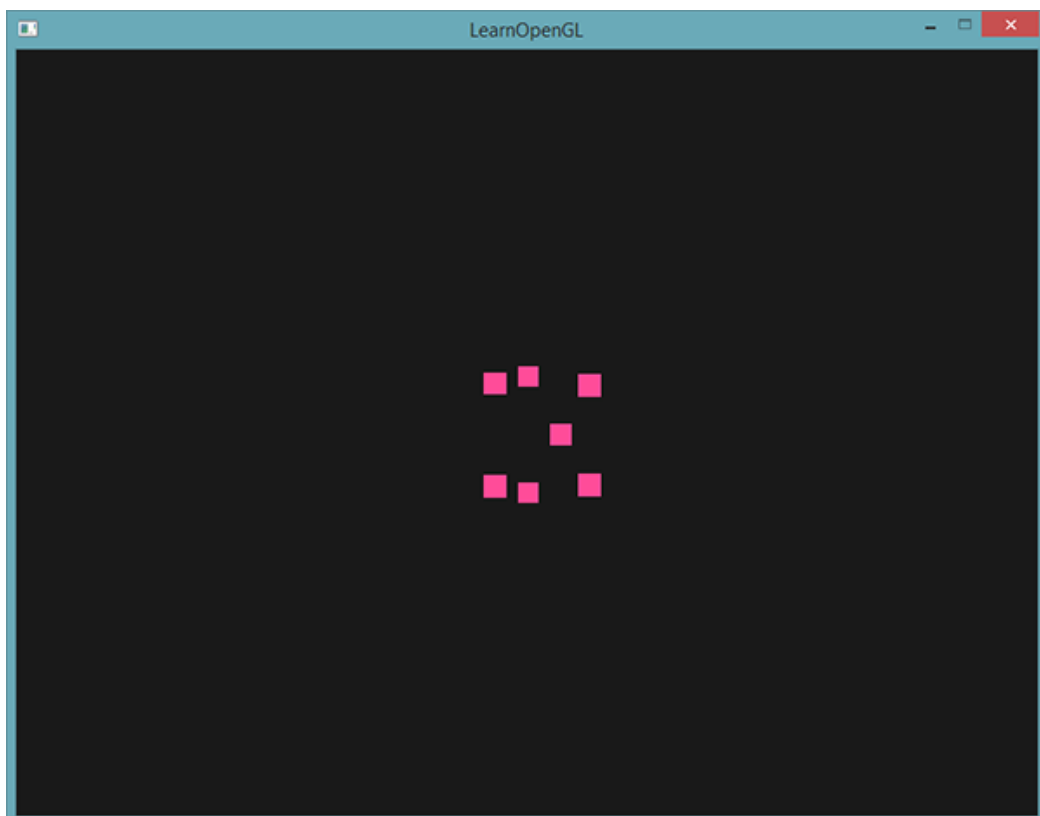

You can imagine that varying the point size per vertex is interesting for techniques like particle generation.

29.2.2 `gl_VertexID`

The `gl_Position` and `gl_PointSize` are *output variables* since their value is read as output from the vertex shader; we can influence the result by writing to them. The vertex shader also gives us an interesting *input variable*, that we can only read from, called `gl_VertexID`.

The integer variable `gl_VertexID` holds the current ID of the vertex we're drawing. When doing *indexed rendering* (with `glDrawElements`) this variable holds the current index of the vertex we're drawing. When drawing without indices (via `glDrawArrays`) this variable holds the number of the currently processed vertex since the start of the render call.

Although not particularly useful right now, it's good to know that we have access to info like this.

29.3 Fragment shader variables

Within the fragment shader we also have access to some interesting variables. GLSL gives us two interesting input variables called `gl_FragCoord` and `gl_FrontFacing`.

29.3.1 `gl_FragCoord`

We've seen the `gl_FragCoord` a couple of times during the discussion of depth testing, because the z component of the `gl_FragCoord` vector is equal to the depth value of that particular fragment. However, we can also use the x and y component of the vector for some interesting effects.

The `gl_FragCoord`'s x and y component are the window-space coordinates of the fragment, originating from the bottom-left of the window. We have a window of 800x600 so the window-space coordinates of the fragment will have x values between 0 and 800, and y values between 0 and 600.

Using the fragment shader we can calculate a different color value based on the window coordinate of the fragment. A common usage for the `gl_FragCoord` variable is for comparing visual output of different fragment calculations, as usually seen in tech demos. We could for example split the screen in two by rendering one output to the left side of the window and another output to the right side of the window. An example fragment shader that outputs a different color based on the fragment's window coordinates is given below:

```
void main()
{
    if(gl_FragCoord.x < 400)
        color = vec4(1.0f, 0.0f, 0.0f, 1.0f);
    else
        color = vec4(0.0f, 1.0f, 0.0f, 1.0f);
}
```

Because the width of the window is equal to 800, whenever a pixel's x-coordinate is less than 400 it must be at the left side of the window and thus we give the object a different color.

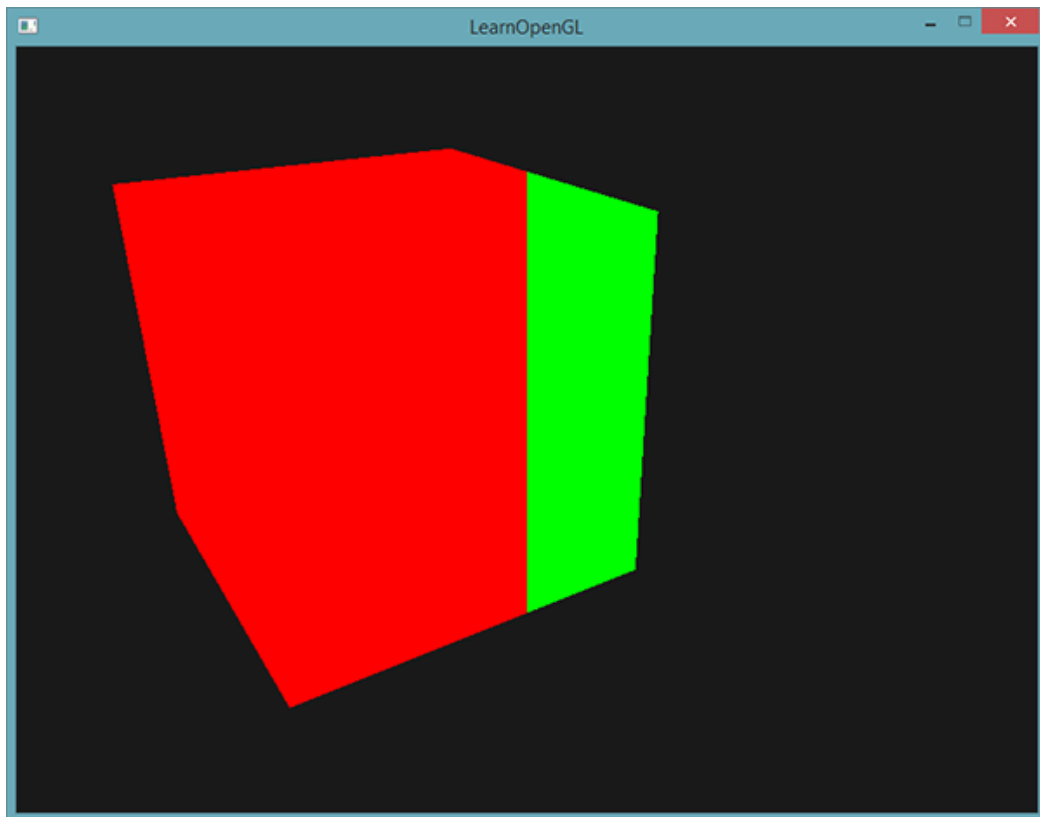

We can now calculate two completely different fragment shader results and display each of them on a different side of the window. This is great for testing out different lighting techniques for example.

29.3.2 `gl_FrontFacing`

Another interesting input variable in the fragment shader is the `gl_FrontFacing` variable. In the [face culling](#) tutorial we mentioned that OpenGL is able to figure out if a face is a front or back face due to the winding order of the vertices. If we're not using face culling (by enabling `GL_FACE_CULL`) then the `gl_FrontFacing` variable tells us if the current fragment is part of a front-facing or a back-facing face. We could then decide to calculate different colors for front faces for example.

The `gl_FrontFacing` variable is a `bool` that is `true` if the fragment is part of a front face and else `false`. We could for example create a cube this way with a different texture on the inside than on the outside:

```
#version 330 core
out vec4 color;
in vec2 TexCoords;

uniform sampler2D frontTexture;
uniform sampler2D backTexture;
```

```
void main()
{
    if (gl_FrontFacing)
        color = texture(frontTexture, TexCoords);
    else
        color = texture(backTexture, TexCoords);
}
```

So if we take a peek inside the container we can now see a different texture being used.

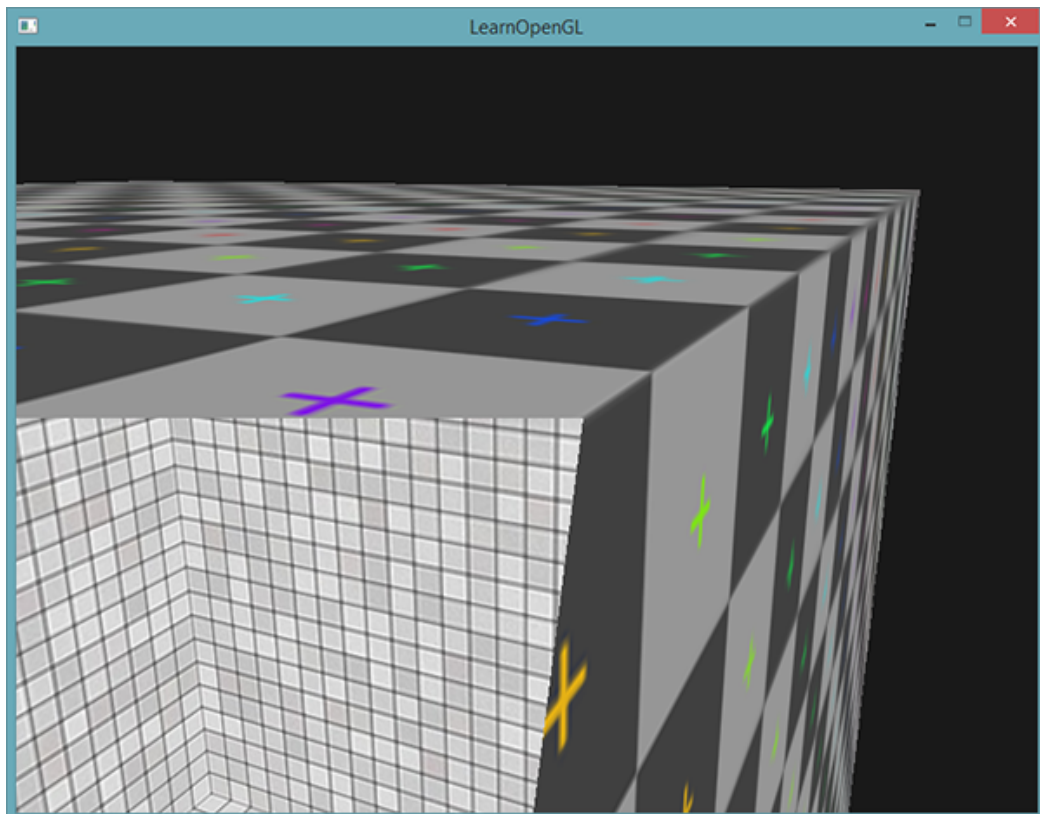

Note that if you enabled face culling you won't be able to see any faces inside the container and using `gl_FrontFacing` would then be pointless.

29.3.3 `gl_FragDepth`

The input variable `gl_FragCoord` is an input variable that allows us to read window-space coordinates and get the depth value of the current fragment, but it is a **read-only** variable. We can't influence the window-space coordinates of the fragment, but it is possible to actually set the depth value of the fragment. GLSL gives us an output variable called `gl_FragDepth` that we can use to set the depth value of the fragment within the shader.

To actually set the depth value in the shader we simply write a **float** value between `0.0` and `1.0` to the output variable:

```
gl_FragDepth = 0.0f; // This fragment now has a depth value of 0.0f
```

If the shader does not write a value to `gl_FragDepth` the variable will automatically take its value from `gl_FragCoord.z`.

Setting the depth value by our self has a major disadvantage however, because OpenGL disables all **early depth testing** (as discussed in the [depth testing](#) tutorial) as soon as we write to `gl_FragDepth` in the fragment shader. It is disabled, because OpenGL cannot know what depth value the fragment will have *before* we run the fragment shader, since the fragment shader might completely change this depth value.

By writing to `gl_FragDepth` you should take this performance penalty into consideration. From OpenGL 4.2 however, we can still sort of mediate between both sides by redeclaring the `gl_FragDepth` variable at the top of the fragment shader with a **depth condition**:

```
layout (depth_<condition>) out float gl_FragDepth;
```

This condition can take the following values:

Condition	Description
any	The default value. Early depth testing is disabled and you lose most performance.
greater	You can only make the depth value larger compared to <code>gl_FragCoord.z</code> .
less	You can only make the depth value smaller compared to <code>gl_FragCoord.z</code> .
unchanged	If you write to <code>gl_FragDepth</code> , you will write exactly <code>gl_FragCoord.z</code> .

By specifying `greater` or `less` as the depth condition OpenGL can make the assumption that you'll only write depth values larger or greater than the fragment's depth value. This way OpenGL is still able to do an early depth test in cases where the depth value is smaller than the fragment's depth value.

An example of where we increment the depth value in the fragment shader, but still want to preserve some of the early depth testing is shown in the fragment shader below:

```
#version 330 core
layout (depth_greater) out float gl_FragDepth;
out vec4 color;

void main()
{
    color = vec4(1.0f);
    gl_FragDepth = gl_FragCoord.z + 0.1f;
}
```

Do note that this feature is only available from OpenGL version 4.2 or higher.

29.4 Interface blocks

So far, every time we wanted to send data from the vertex to the fragment shader we declared several matching input/output variables. Declaring these one at a time is the easiest way to send data from one shader to another, but as applications become larger you probably want to send more than a few variables over which may include arrays and/or structs.

To help us organize these variables GLSL offers us something called **interface blocks** that allows us to group together those variables. The declaration of such an interface block looks a lot

like a `struct` declaration, except that it is now declared using an `in` or `out` keyword based on the block being an input or an output block.

```
#version 330 core
layout (location = 0) in vec3 position;
layout (location = 1) in vec2 texCoords;

uniform mat4 model;
uniform mat4 view;
uniform mat4 projection;

out VS_OUT
{
    vec2 TexCoords;
} vs_out;

void main()
{
    gl_Position = projection * view * model * vec4(position, 1.0f);
    vs_out.TexCoords = texCoords;
}
```

This time we declared an interface block called `vs_out` that groups together all the output variables we want to send to the next shader. This is kind of a trivial example, but you can imagine that this helps organize your shaders' inputs/outputs. It is also useful when we want to group shader input/output into arrays as we'll see in the [next](#) tutorial about geometry shaders.

Then we also need to declare an input interface block in the next shader which is the fragment shader. The `block name` (`VS_OUT`) should be the same in the fragment shader, but the `instance name` (`vs_out` as used in the vertex shader) can be anything we like - avoiding confusing names like `vs_out` that actually contains input variables.

```
#version 330 core
out vec4 color;

in VS_OUT
{
    vec2 TexCoords;
} fs_in;

uniform sampler2D texture;

void main()
{
    color = texture(texture, fs_in.TexCoords);
}
```

As long as both interface block names are equal, their corresponding input and output is matched together. This is another useful feature that helps organize your code and proves useful when crossing between certain shader stages like the geometry shader.

29.5 Uniform buffer objects

We've been using OpenGL for quite a while now and learned some pretty cool tricks, but also a few annoyances. For example, when using more than 1 shader we continually have to set uniform

variables where most of them are exactly the same for each shader - so why bother to even set them again?

OpenGL gives us a tool called **uniform buffer objects** that allow us to declare a set of *global* uniform variables that remain the same over several shader programs. When using uniform buffer objects we thus have to set the relevant uniforms only **once**. We do still have to manually set the uniforms that are unique per shader. Creating and configuring a uniform buffer object requires a bit of work though.

Because a uniform buffer object is a buffer like any other buffer we can create one via `glGenBuffers`, bind it to the `GL_UNIFORM_BUFFER` buffer target and store all the relevant uniform data into the buffer. There are certain rules as to how the data for uniform buffer objects should be stored and we'll get to that later. First, we'll take a simple vertex shader and store our `projection` and `view` matrix in a so called **uniform block**:

```
#version 330 core
layout (location = 0) in vec3 position;

layout (std140) uniform Matrices
{
    mat4 projection;
    mat4 view;
};

uniform mat4 model;

void main()
{
    gl_Position = projection * view * model * vec4(position, 1.0);
}
```

In most of our samples we set a projection and view uniform matrix each render iteration for each shader we're using. This is a perfect example of where uniform buffer objects become useful since now we only have to store these matrices once.

Here we declared a uniform block called `Matrices` that stores two 4x4 matrices. Variables in a uniform block can be directly accessed without the block name as a prefix. Then we store these matrix values in a buffer somewhere in the OpenGL code and each shader that declared this uniform block has access to the matrices.

You're probably wondering right now what the `layout (std140)` statement means. What this says is that the currently defined uniform block uses a specific memory layout for its content; this statement sets the **uniform block layout**.

29.6 Uniform block layout

The content of a uniform block is stored in a buffer object which is basically nothing more than a reserved piece of memory. Because this piece of memory holds no information on what kind of data it holds, we need to tell OpenGL what parts of the memory corresponds to which uniform variables in the shader.

Imagine the following uniform block in a shader:

```
layout (std140) uniform ExampleBlock
{
    float value;
    vec3 vector;
    mat4 matrix;
    float values[3];
    bool boolean;
    int integer;
};
```

What we want to know is the size (in bytes) and the offset (from the start of the block) of each of these variables so we can place them in the buffer in their respective order. The size of each of the elements is clearly stated in OpenGL and directly corresponds to C++ data types; vectors and matrices being (large) arrays of floats. What OpenGL doesn't clearly state is the *spacing* between the variables. This allows the hardware to position variables as it sees fit. Some hardware is able to place a `vec3` adjacent to a `float` for example. Not all hardware can handle this and pads the `vec3` to an array of 4 floats before appending the `float`. A great feature, but inconvenient for us.

By default GLSL uses a uniform memory layout called a *shared* layout - shared because once the offsets are defined by the hardware, they are consistently *shared* between multiple programs. With a shared layout GLSL is allowed to reposition the uniform variables for optimization as long as the variables' order remains intact. Because we don't know at what offset each uniform variable will be we don't know how to precisely fill our uniform buffer. We can query this information with functions like `glGetUniformIndices`, but that is out of the scope of this tutorial.

While a shared layout gives us some space-saving optimizations, we'd need to query each offset for each uniform variable which translates to a lot of work. The general practice is however to not use the shared layout, but to use the `std140` layout. The `std140` layout **explicitly** states the memory layout for each variable type by stating their respective offsets governed by a set of rules. Since this is explicitly mentioned we can manually figure out the offsets for each variable.

Each variable has a *base alignment* which is equal to the space a variable takes (including padding) within a uniform block - this base alignment is calculated using the `std140` layout rules. Then, for each variable, we calculate its *aligned offset* which is the byte offset of a variable from the start of the block. The aligned byte offset of a variable **must** be equal to a multiple of its base alignment.

The exact layout rules can be found at OpenGL's uniform buffer specification [here](#), but we'll list the most common rules below. Each variable type in GLSL such as `int`, `float` and `bool` are defined to be four-byte quantities with each entity of 4 bytes being represented as N.

Like most of OpenGL's specifications it's easier to understand with an example. We're taking the uniform block called `ExampleBlock` we introduced earlier and calculate the aligned offset for each of its members using the `std140` layout:

```
layout (std140) uniform ExampleBlock
{
    //           // base alignment // aligned offset
    float value; // 4           // 0
```

Type	Layout rule
Scalar e.g. <code>int</code> or <code>bool</code>	Each scalar has a base alignment of N.
Vector Either 2N or 4N.	This means that a <code>vec3</code> has a base alignment of 4N.
Array of scalars or vectors	Each element has a base alignment equal to that of a <code>vec4</code> .
Matrices	Stored as a large array of column vectors, where each of those vectors has a base alignment of <code>vec4</code> .
Struct	Equal to the computed size of its elements according to the previous rules, but padded to a multiple of the size of a <code>vec4</code> .

```

vec3 vector;      // 16          // 16 (must be multiple of 16 so
4->16)
mat4 matrix;     // 16          // 32 (column 0)
                // 16          // 48 (column 1)
                // 16          // 64 (column 2)
                // 16          // 80 (column 3)
float values[3]; // 16          // 96 (values[0])
                // 16          // 112 (values[1])
                // 16          // 128 (values[2])
bool boolean;   // 4           // 144
int integer;    // 4           // 148
};

```

As an exercise, try to calculate the offset values yourself and compare them to this table. With the calculated offset values, based on the rules of the `std140` layout, we can fill the buffer with the variable data at each offset using functions like `glBufferSubData`. While not the most efficient, the `std140` layout does guarantee us that the memory layout remains the same over each program that declared this uniform block.

By adding the statement `layout (std140)` before the definition of the uniform block we tell OpenGL that this uniform block uses the `std140` layout. There are two other layouts to choose from that require us to query each offset before filling the buffers. We've already seen the `shared` layout and the other remaining layout being `packed`. When using the `packed` layout, there is no guarantee that the layout remains the same between programs (not shared) because it allows the compiler to optimize uniform variables away from the uniform block which might differ per shader.

29.7 Using uniform buffers

We've discussed defining uniform blocks in the shaders and specifying their memory layout, but we haven't discussed how to actually use them yet.

First we need to create a uniform buffer object which is done via `glGenBuffers`. Once we have a buffer object we bind it to the `GL_UNIFORM_BUFFER` target and allocate enough memory by calling `glBufferData`.

```

GLuint uboExampleBlock;
glGenBuffers(1, &uboExampleBlock);

```



```
glBindBuffer(GL_UNIFORM_BUFFER, uboExampleBlock);
glBufferData(GL_UNIFORM_BUFFER, 150, NULL, GL_STATIC_DRAW); // allocate 150
    bytes of memory
glBindBuffer(GL_UNIFORM_BUFFER, 0);
```

Now whenever we want to update or insert data into the buffer, we bind to `uboExampleBlock` and use `glBufferSubData` to update its memory. We only have to update this uniform buffer once, and all shaders that use this buffer now use its updated data. But, how does OpenGL know what uniform buffers correspond to which uniform blocks?

In the OpenGL context there is a number of **binding points** defined where we can link a uniform buffer to. Once we created a uniform buffer we link it to one of those binding points and we also link the uniform block in the shader to the same binding point, effectively linking those to each other. The following diagram illustrates this:

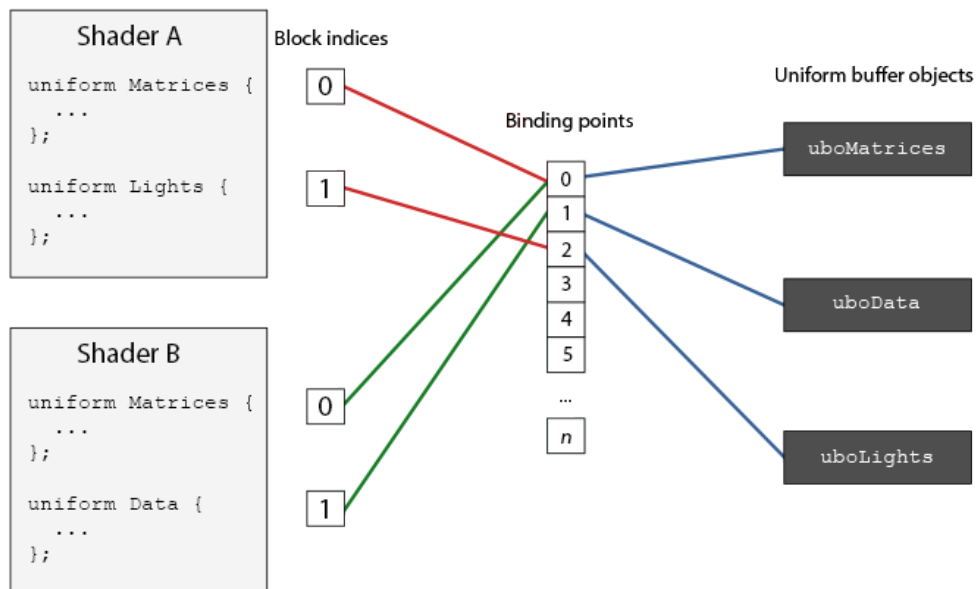

As you can see we can bind multiple uniform buffers to different binding points. Because shader A and shader B both have a uniform block linked to the same binding point 0 their uniform blocks share the same uniform data found in `uboMatrices`; a requirement being that both shaders defined the same `Matrices` uniform block.

To set the uniform block to a specific binding point we call `glUniformBlockBinding` that takes a program object as its first argument, a uniform block index and the binding point to link to. The **uniform block index** is a location index of the defined uniform block in the shader. This can be retrieved via a call to `glGetUniformBlockIndex` that accepts a program object and the name of the uniform block. We can set the `Lights` uniform block from the diagram to binding point 2 as follows:

```
GLuint lights_index = glGetUniformBlockIndex(shaderA.Program, "Lights");
glUniformBlockBinding(shaderA.Program, lights_index, 2);
```

Note that we have to repeat this process for **each** shader.

From OpenGL version 4.2 and onwards it is also possible to store the binding point of a uniform block explicitly in the shader by adding another layout specifier, saving us the calls to `glGetUniformBlockIndex` and `glUniformBlockBinding`. The following code sets the binding point of the `Lights` uniform block explicitly:

```
layout(std140, binding = 2) uniform Lights { ... };
```

Then we also need to bind the uniform buffer object to the same binding point and this can be accomplished with either `glBindBufferBase` or `glBindBufferRange`.

```
glBindBufferBase(GL_UNIFORM_BUFFER, 2, uboExampleBlock);
// or
glBindBufferRange(GL_UNIFORM_BUFFER, 2, uboExampleBlock, 0, 150);
```

The function `glBindBufferBase` expects a target, a binding point index and a uniform buffer object as its arguments. This function links `uboExampleBlock` to binding point 2 and from this point on both sides of the binding point are linked. You can also use the `glBindBufferRange` function that expects an extra offset and size parameter - this way you can bind only a specific range of the uniform buffer to a binding point. Using `glBindBufferRange` you could have multiple different uniform blocks linked to a single uniform buffer object.

Now that everything is set up, we can start adding data to the uniform buffer. We could add all the data as a single byte array or update parts of the buffer whenever we feel like it using `glBufferSubData`. To update the uniform variable `boolean` we could update the uniform buffer object as follows:

```
glBindBuffer(GL_UNIFORM_BUFFER, uboExampleBlock);
GLint b = true; // booleans in GLSL are represented as 4 bytes, so we store it
                // in an integer
glBufferSubData(GL_UNIFORM_BUFFER, 142, 4, &b);
glBindBuffer(GL_UNIFORM_BUFFER, 0);
```

And the same procedure applies for all the other uniform variables inside the uniform block, but with different range arguments.

29.8 A simple example

So let's demonstrate a real useful example of using uniform buffer objects. If we look back at all the previous code samples we've continually been using 3 matrices: the projection, view and model matrices. Of all those matrices, only the model matrix changes frequently. If we have multiple shaders that use this same set of matrices, we'd probably be better off using uniform buffer objects.

We're going to store the projection and view matrix in a uniform block called `Matrices`. We're not going to store the model matrix in there, since the model matrix tends to change quite frequently between shaders so we wouldn't really benefit from uniform buffer objects then.

```
#version 330 core
layout (location = 0) in vec3 position;
```

```

layout (std140) uniform Matrices
{
    mat4 projection;
    mat4 view;
};
uniform mat4 model;

void main()
{
    gl_Position = projection * view * model * vec4(position, 1.0);
}

```

Not much special going on here, except that we now use a uniform block with a std140 layout. What we're going to do in our sample application is display 4 cubes where each cube is displayed using a different shader program. Each of the 4 shader programs uses the same vertex shader, but has a different fragment shader that only outputs a single color that differs per shader.

First, we set the uniform block of the vertex shaders equal to binding point 0. Note that we have to do this for each shader.

```

GLuint uniformBlockIndexRed = glGetUniformLocation(shaderRed.Program, "
    Matrices");
GLuint uniformBlockIndexGreen = glGetUniformLocation(shaderGreen.Program,
    "Matrices");
GLuint uniformBlockIndexBlue = glGetUniformLocation(shaderBlue.Program, "
    Matrices");
GLuint uniformBlockIndexYellow = glGetUniformLocation(shaderYellow.
    Program, "Matrices");

glUniformBlockBinding(shaderRed.Program, uniformBlockIndexRed, 0);
glUniformBlockBinding(shaderGreen.Program, uniformBlockIndexGreen, 0);
glUniformBlockBinding(shaderBlue.Program, uniformBlockIndexBlue, 0);
glUniformBlockBinding(shaderYellow.Program, uniformBlockIndexYellow, 0);

```

Next we create the actual uniform buffer object and also bind the buffer to binding point 0:

```

GLuint uboMatrices
glGenBuffers(1, &uboMatrices);

glBindBuffer(GL_UNIFORM_BUFFER, uboMatrices);
glBufferData(GL_UNIFORM_BUFFER, 2 * sizeof(glm::mat4), NULL, GL_STATIC_DRAW
);
glBindBuffer(GL_UNIFORM_BUFFER, 0);

glBindBufferRange(GL_UNIFORM_BUFFER, 0, uboMatrices, 0, 2 * sizeof(glm::
mat4));

```

First we allocate enough memory for our buffer which is equal to 2 times the size of `glm::mat4`. The size of GLM's matrix types correspond directly to `mat4` in GLSL. Then we link a specific range of the buffer which in this case is the entire buffer, to binding point 0.

Now all that's left to do is actually fill the buffer. If we keep the *field of view* value constant of the projection matrix (so no more camera zoom) we only have to define it once in our application - this means we only have to insert this into the buffer only once as well. Because we already allocated enough memory in the buffer object we can use `glBufferSubData` to store the projection matrix before we enter the game loop:

```
glm::mat4 projection = glm::perspective(45.0f, (float)width/(float)height,
    0.1f, 100.0f);
glBindBuffer(GL_UNIFORM_BUFFER, uboMatrices);
glBufferSubData(GL_UNIFORM_BUFFER, 0, sizeof(glm::mat4), glm::value_ptr(
    projection));
glBindBuffer(GL_UNIFORM_BUFFER, 0);
```

Here we store the first half of the uniform buffer with the projection matrix. Before we draw the objects each render iteration we then update the second half of the buffer with the view matrix:

```
glm::mat4 view = camera.GetViewMatrix();
glBindBuffer(GL_UNIFORM_BUFFER, uboMatrices);
glBufferSubData(
    GL_UNIFORM_BUFFER, sizeof(glm::mat4), sizeof(glm::mat4), glm::value_ptr(
        view));
glBindBuffer(GL_UNIFORM_BUFFER, 0);
```

And that's it for uniform buffer objects. Each vertex shader that contains a `Matrices` uniform block will now contain the data stored in `uboMatrices`. So if we now were to draw 4 cubes using 4 different shaders their projection and view matrix should remain the same:

```
glBindVertexArray(cubeVAO);
shaderRed.Use();
glm::mat4 model;
model = glm::translate(model, glm::vec3(-0.75f, 0.75f, 0.0f)); // Move
    top-left
glUniformMatrix4fv(modelLoc, 1, GL_FALSE, glm::value_ptr(model));
glDrawArrays(GL_TRIANGLES, 0, 36);
// ... Draw Green Cube
// ... Draw Blue Cube
// ... Draw Yellow Cube
glBindVertexArray(0);
```

The only uniform we still need to set is the `model` uniform. Using uniform buffer objects in a scenario like this saves us from quite a few uniform calls per shader. The result looks something like this:

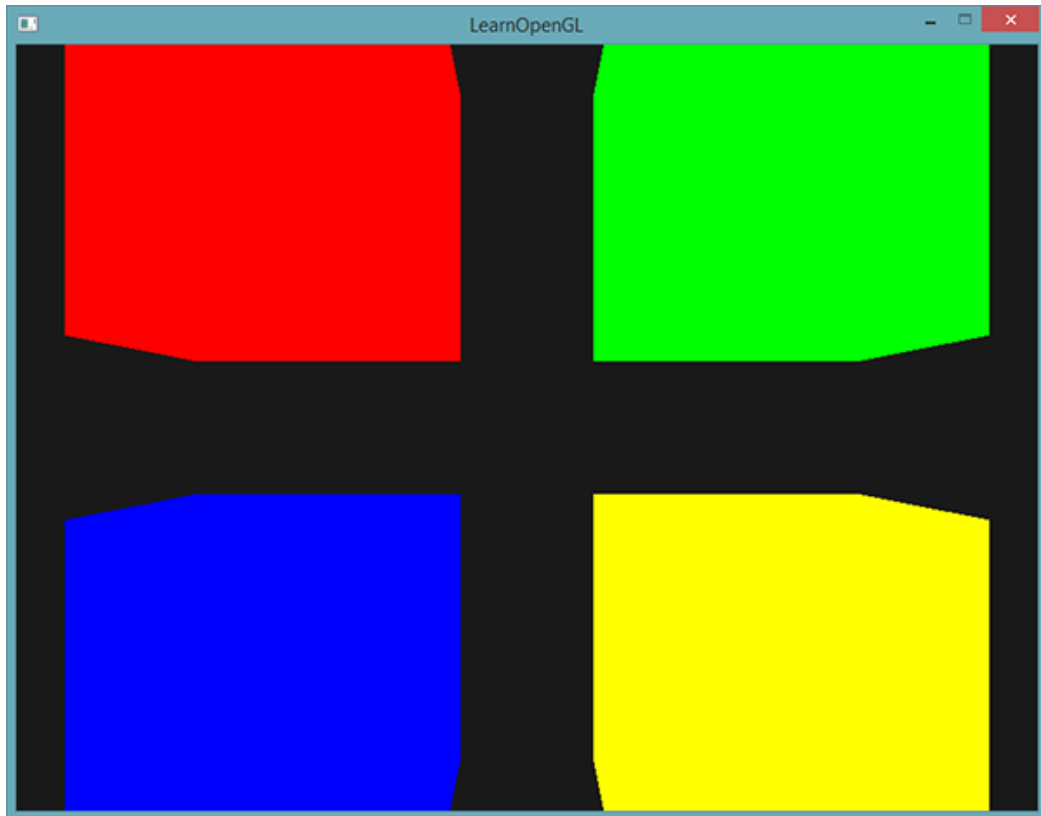

Each of the cube is moved to one side of the window by altering the model matrix and due to the different fragment shaders their object colors differ. This is a relatively simple scenario of where we might use uniform buffer objects, but any large rendering application could have over hundreds of shader programs active; this is where uniform buffer objects really start to shine.

You can find the full source code of the uniform example application [here](#).

Uniform buffer objects have several advantages over single uniforms. First, setting a lot of uniforms at once is faster than setting multiple uniforms one at a time. Second, if you want to change the same uniform over several shaders, it is much easier to change a uniform once in a uniform buffer. One last advantage that is not immediately apparent is that you can use a lot more uniforms in shaders using uniform buffer objects. OpenGL has a limit to how much uniform data it can handle that can be queried with `GL_MAX_VERTEX_UNIFORM_COMPONENTS`. When using uniform buffer objects, this limit is much higher. So whenever you reach a maximum number of uniforms (when doing skeletal animation for example) you could always use uniform buffer objects.



30. Geometry Shader

Between the vertex and the fragment shader there is an optional shader stage called the **geometry shader**. A geometry shader takes as input a set of vertices that form a single primitive e.g. a point or a triangle. The geometry shader can then transform these vertices as it sees fit before sending them to the next shader stage. What makes the geometry shader interesting however is that it is able to transform the (set of) vertices to completely different primitives possibly generating much more vertices than were initially given.

We're going to throw you right into the deep by showing you an example of a geometry shader:

```
#version 330 core
layout (points) in;
layout (line_strip, max_vertices = 2) out;

void main() {
    gl_Position = gl_in[0].gl_Position + vec4(-0.1, 0.0, 0.0, 0.0);
    EmitVertex();

    gl_Position = gl_in[0].gl_Position + vec4(0.1, 0.0, 0.0, 0.0);
    EmitVertex();

    EndPrimitive();
}
```

At the start of every geometry shader we need to declare the type of primitive input we're receiving from the vertex shader. We do this by declaring a layout specifier in front of the **in** keyword. This input layout qualifier can take any of the following primitive values from a vertex shader:

- **points**: when drawing `GL_POINTS` primitives (1).
- **lines**: when drawing `GL_LINES` or `GL_LINE_STRIP` (2).
- **lines_adjacency**: `GL_LINES_ADJACENCY` or `GL_LINE_STRIP_ADJACENCY` (4).

- triangles: `GL_TRIANGLES`, `GL_TRIANGLE_STRIP` or `GL_TRIANGLE_FAN` (3).
- triangles_adjacency : `GL_TRIANGLES_ADJACENCY` or `GL_TRIANGLE_STRIP_ADJACENCY` (6).

These are almost all the rendering primitives we're able to give to rendering calls like `glDrawArrays`. If we'd chosen to draw vertices as `GL_TRIANGLES` we should set the input qualifier to `triangles`. The number within the parenthesis represents the minimal number of vertices a single primitive contains.

Then we also need to specify a primitive type that the geometry shader will actually output and we do this via a layout specifier in front of the `out` keyword. Like the input layout qualifier, the output layout qualifier can also take several primitive values:

- `points`
- `line_strip`
- `triangle_strip`

With just these 3 output specifiers we can create almost any shape we want from the input primitives. To generate a single triangle for example we'd specify `triangle_strip` as the output and then output 3 vertices.

The geometry shader also expects us to set a maximum number of vertices it outputs (if you exceed this number, OpenGL won't draw the *extra* vertices) which we can also do within the layout qualifier of the `out` keyword. In this particular case we're going to output a `line_strip` with a maximum number of 2 vertices.

In case you are wondering what a line strip is: a line strip binds together a set of points to form one continuous line between them with a minimum of 2 points. Each extra point given to the rendering call results in a new line between the new point and the previous point as you can see in the image below where we have 5 point vertices:

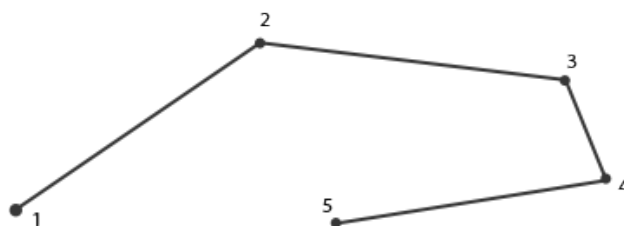

With the current shader we'll only output a single line since the maximum number of vertices is equal to 2.

To generate meaningful results we need some way to retrieve the output from the previous shader stage. GLSL gives us a **built-in** variable called `gl_in` that internally (probably) looks something like this:

```
in gl_Vertex
{
    vec4 gl_Position;
    float gl_PointSize;
    float gl_ClipDistance[];
```

```
} gl_in[];
```

Here it is declared as an **interface block** (as discussed in the [previous tutorial](#)) that contains a few interesting variables of which the most interesting one is `gl_Position` that contains the similar vector we set as the vertex shader's output.

Note that it is declared as an array, because most render primitives consist of more than 1 vertex and the geometry shader receives **all** vertices of a primitive as its input.

Using the vertex data from the previous vertex shader stage we can start to generate new data which is done via 2 geometry shader functions called `EmitVertex` and `EndPrimitive`. The geometry shader expects you to generate/output at least one of the primitives you specified as output. In our case we want to at least generate one line strip primitive.

```
void main() {  
    gl_Position = gl_in[0].gl_Position + vec4(-0.1, 0.0, 0.0, 0.0);  
    EmitVertex();  
  
    gl_Position = gl_in[0].gl_Position + vec4(0.1, 0.0, 0.0, 0.0);  
    EmitVertex();  
  
    EndPrimitive();  
}
```

Each time we call `EmitVertex` the vector currently set to `gl_Position` is added to the primitive. Whenever `EndPrimitive` is called, all emitted vertices for this primitive are combined into the specified output render primitive. By repeatedly calling `EndPrimitive` after one or more `EmitVertex` calls multiple primitives can be generated. This particular case emits two vertices that were translated by a small offset from the original vertex position and then calls `EndPrimitive`, combining these two vertices into a single line strip of 2 vertices.

Now that you (sort of) know how geometry shaders work you can probably guess what this geometry shader does. This geometry shader takes a point primitive as its input and creates a horizontal line primitive with the input point at its center. If we were to render this it looks something like this:

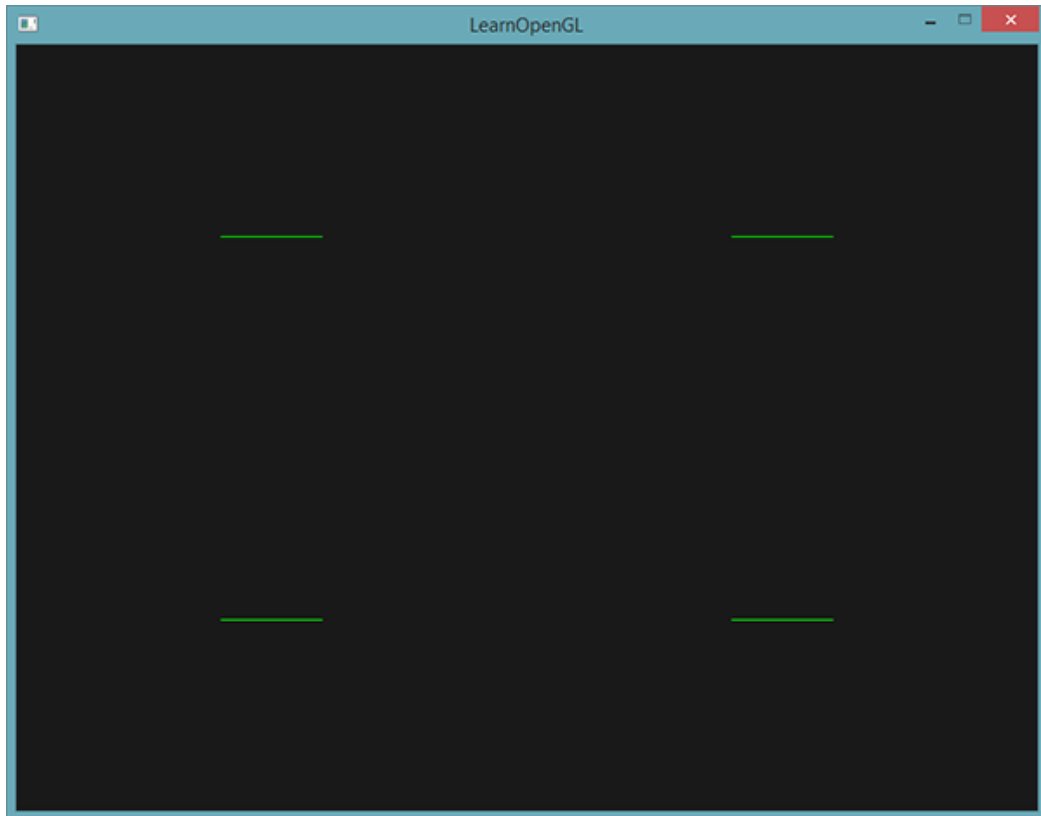

Not very impressive yet, but it's interesting to consider that this output was generated using just the following render call:

```
glDrawArrays(GL_POINTS, 0, 4);
```

While this is a relatively simple example, it does show you how we can use geometry shaders to (dynamically) generate new shapes on the fly. Later in this tutorial we'll discuss some interesting effects that we can achieve using geometry shaders, but for now we're going to start by creating a simple geometry shader.

30.1 Using geometry shaders

To demonstrate the use of a geometry shader we're going to render a really simple scene where we just draw 4 points on the z-plane in normalized device coordinates. The coordinates of the points are:

```
GLfloat points[] = {  
    -0.5f, 0.5f, // Top-left  
     0.5f, 0.5f, // Top-right  
     0.5f, -0.5f, // Bottom-right  
    -0.5f, -0.5f // Bottom-left  
};
```

The vertex shader only needs to draw the points on the z-plane so we'll only need a basic vertex shader:

```
#version 330 core
layout (location = 0) in vec2 position;

void main()
{
    gl_Position = vec4(position.x, position.y, 0.0f, 1.0f);
}
```

And we'll simply output the color green for all points which we hardcode in the fragment shader:

```
#version 330 core
out vec4 color;

void main()
{
    color = vec4(0.0f, 1.0f, 0.0f, 1.0f);
}
```

Generate a VAO and a VBO for the points' vertex data and then draw them via `glDrawArrays`:

```
shader.Use();
glBindVertexArray(VAO);
glDrawArrays(GL_POINTS, 0, 4);
glBindVertexArray(0);
```

The result is a dark scene with 4 (difficult to see) green points:

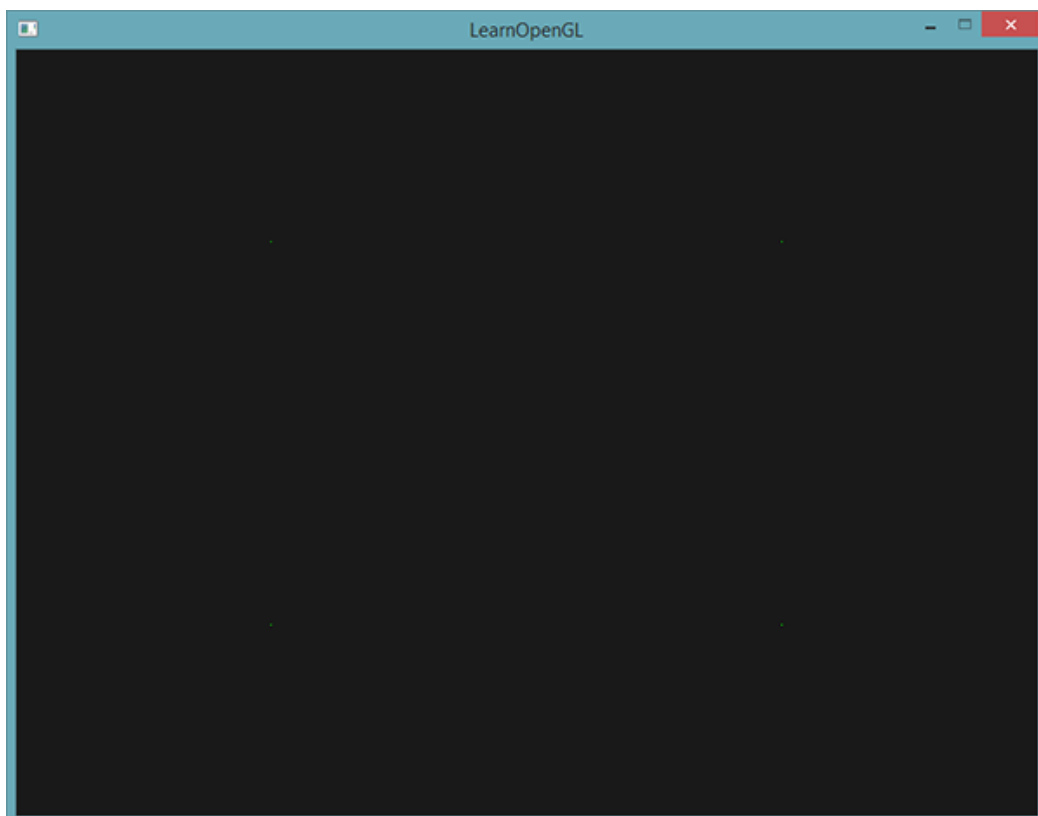

But didn't we already learn to do all this? Yes, and now we're going to spice this little scene up by adding a geometry shader to the scene.

For learning purposes we're going to create what is called a **pass-through** geometry shader that takes a point primitive as its input and *passes* it to the next shader unmodified:

```
#version 330 core
layout (points) in;
layout (points, max_vertices = 1) out;

void main() {
    gl_Position = gl_in[0].gl_Position;
    EmitVertex();
    EndPrimitive();
}
```

By now this geometry shader should be fairly easy to understand. It simply emits the unmodified vertex position it received as input and generates a point primitive.

A geometry shader needs to be compiled and linked to a program just like the vertex and fragment shader, but this time we'll create the shader using `GL_GEOMETRY_SHADER` as the shader type:

```
geometryShader = glCreateShader(GL_GEOMETRY_SHADER);
glShaderSource(geometryShader, 1, &gShaderCode, NULL);
glCompileShader(geometryShader);
...
glAttachShader(program, geometryShader);
glLinkProgram(program);
```

The shader compilation code is basically the same as the vertex and fragment shader code. Be sure to check for compile or linking errors!

If you'd now compile and run you should be looking at a result similar to the following:

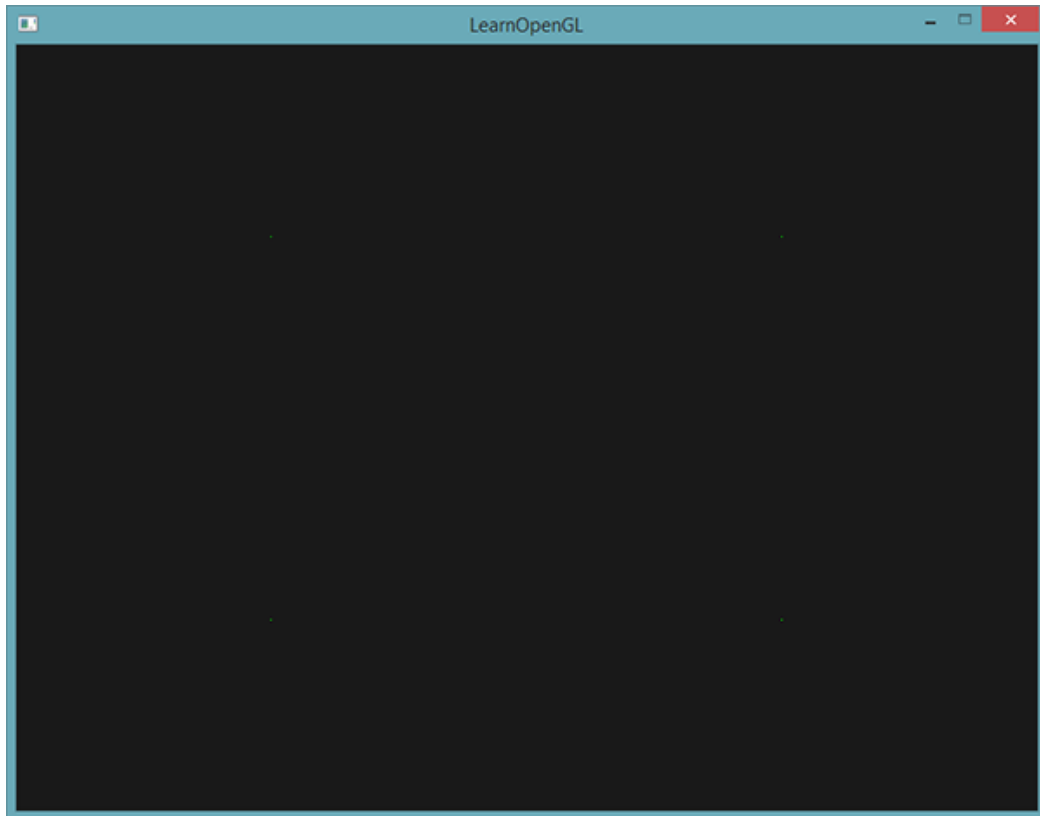

It's exactly the same as without the geometry shader! It's a bit dull, I'll admit that, but the fact that we were still able to draw the points means that the geometry shader works, so now it's time for the more funky stuff!

30.2 Let's build some houses

Drawing points and lines isn't that interesting so we're going to get a little creative by using the geometry shader to draw a house for us at the location of each point. We can achieve this by setting the output of the geometry shader to `triangle_strip` and draw a total of three triangles: two for a square and one for the roof.

A triangle strip in OpenGL is a more efficient way to draw triangles using less vertices. After the first triangle is drawn, each subsequent vertex will generate another triangle next to the first triangle: every 3 adjacent vertices will form a triangle. If we have a total of 6 vertices that form a triangle strip we'd get the following triangles: (1,2,3), (2,3,4), (3,4,5) and (4,5,6) forming a total of 4 triangles. A triangle strip needs at least 3 vertices and will generate $N-2$ triangles; with 6 vertices we created $6-2 = 4$ triangles. The following image illustrates this:

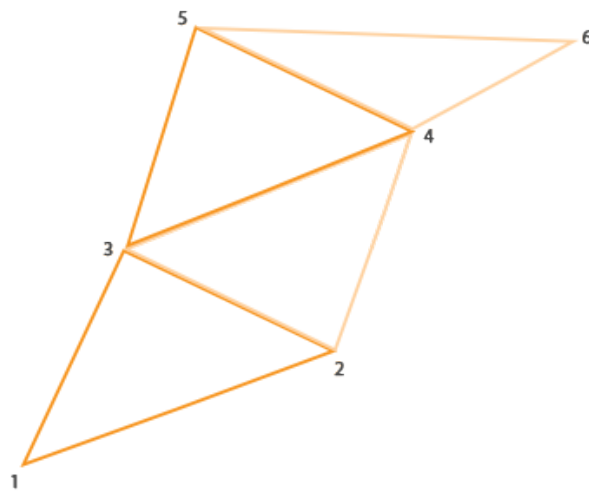

Using a triangle strip as the output of the geometry shader we can easily create the house shape we're after by generating 3 adjacent triangles in the correct order. The following image shows in what order we need to draw what vertices to get the triangles we need with the blue dot being the input point:

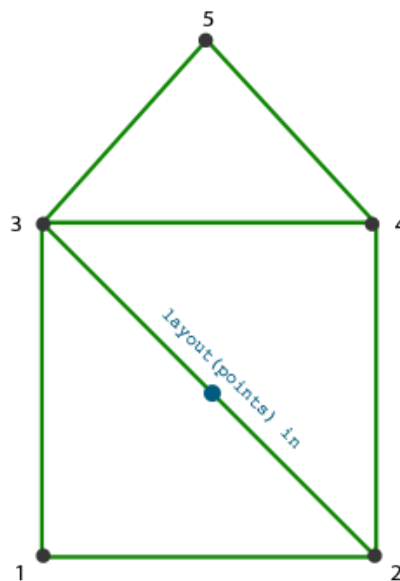

This translates to the following geometry shader:

```
#version 330 core
layout (points) in;
layout (triangle_strip, max_vertices = 5) out;

void build_house(vec4 position)
{
    gl_Position = position + vec4(-0.2f, -0.2f, 0.0f, 0.0f); // 1:bottom
    -left
    EmitVertex();
    gl_Position = position + vec4( 0.2f, -0.2f, 0.0f, 0.0f); // 2:bottom
    -right
    EmitVertex();
```

```

    gl_Position = position + vec4(-0.2f, 0.2f, 0.0f, 0.0f); // 3:top-
    left
    EmitVertex();
    gl_Position = position + vec4( 0.2f, 0.2f, 0.0f, 0.0f); // 4:top-
    right
    EmitVertex();
    gl_Position = position + vec4( 0.0f, 0.4f, 0.0f, 0.0f); // 5:top
    EmitVertex();
    EndPrimitive();
}

void main() {
    build_house(gl_in[0].gl_Position);
}

```

This geometry shader generates 5 vertices, with each vertex being the point's position plus an offset, to form one large triangle strip. The resulting primitive is then rasterized and the fragment shader runs on the entire triangle strip, resulting in a green house for each point we've drawn:

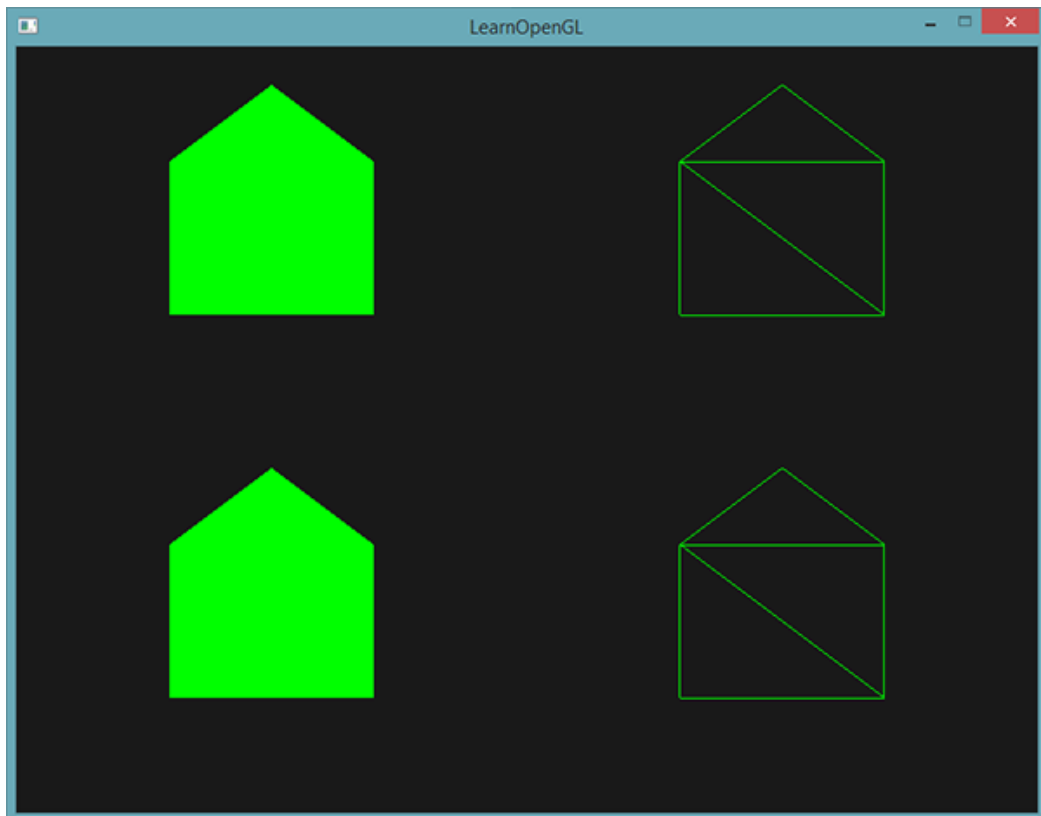

You can see that each house indeed consists of 3 triangles - all drawn using just a single point in space. The green houses do look a bit boring though so let's liven it up a bit by giving each house a unique color. To do this we're going to add an extra vertex attribute with color information per vertex in the vertex shader, direct it to the geometry shader that further forwards it to the fragment shader.

The updated vertex data is given below:

```

GLfloat points[] = {
    -0.5f, 0.5f, 1.0f, 0.0f, 0.0f, // Top-left

```

```

    0.5f, 0.5f, 0.0f, 1.0f, 0.0f, // Top-right
    0.5f, -0.5f, 0.0f, 0.0f, 1.0f, // Bottom-right
    -0.5f, -0.5f, 1.0f, 1.0f, 0.0f // Bottom-left
};

```

Then we update the vertex shader to forward the color attribute to the geometry shader using an interface block:

```

#version 330 core
layout (location = 0) in vec2 position;
layout (location = 1) in vec3 color;

out VS_OUT {
    vec3 color;
} vs_out;

void main()
{
    gl_Position = vec4(position.x, position.y, 0.0f, 1.0f);
    vs_out.color = color;
}

```

Then we also need to declare the same interface block (with a different interface name) in the geometry shader:

```

in VS_OUT {
    vec3 color;
} gs_in[];

```

Because the geometry shader acts on a set of vertices as its input, its input data from the vertex shader is always represented as arrays of data even though we only have a single vertex right now.

We don't necessarily have to use interface blocks to transfer data to the geometry shader. We could have also written it as:

```

in vec3 vColor[];

```

If the vertex shader forwarded the color vector as `out vec3 vColor`. However, interface blocks are much easier to work with in shaders like the geometry shader. In practice, geometry shader inputs can get quite large and grouping them in one large interface block array makes a lot more sense.

Then we should also declare an output color vector for the next fragment shader stage:

```

out vec3 fColor;

```

Because the fragment shader expects only a single (interpolated) color it doesn't make sense to forward multiple colors. The `fColor` vector is thus not an array, but a single vector. When emitting a vertex, each vertex will store the last stored value in `fColor` for its fragment shader run. For the houses, we can thus only fill `fColor` once with the color from the vertex shader before the first vertex is emitted to color the entire house:

```

fColor = gs_in[0].color; // gs_in[0] since there's only one input vertex
gl_Position = position + vec4(-0.2f, -0.2f, 0.0f, 0.0f); // 1:bottom-
left
EmitVertex();
gl_Position = position + vec4( 0.2f, -0.2f, 0.0f, 0.0f); // 2:bottom-
right
EmitVertex();
gl_Position = position + vec4(-0.2f, 0.2f, 0.0f, 0.0f); // 3:top-left
EmitVertex();
gl_Position = position + vec4( 0.2f, 0.2f, 0.0f, 0.0f); // 4:top-right
EmitVertex();
gl_Position = position + vec4( 0.0f, 0.4f, 0.0f, 0.0f); // 5:top
EmitVertex();
EndPrimitive();

```

All the emitted vertices will have the last stored value in `fColor` embedded into their data that is equal to the vertex's color as we defined in their attributes. All the houses will now have a color of their own:

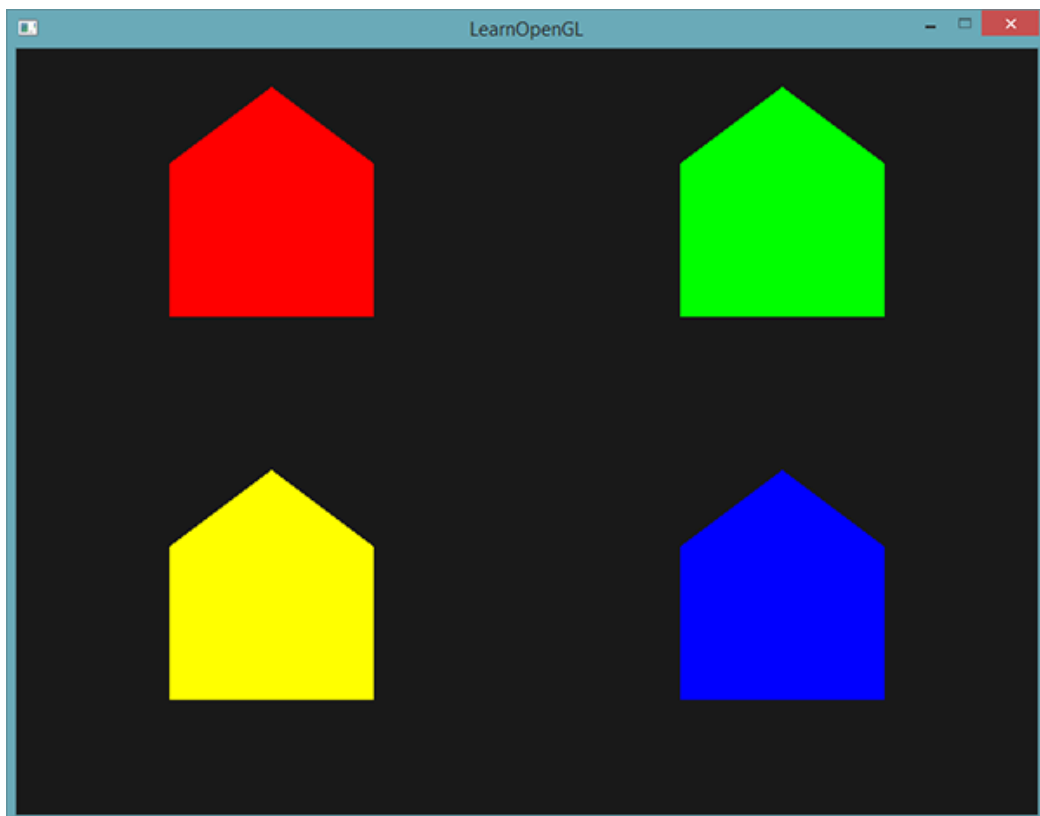

Just for fun we could also pretend it's winter and give their roofs a little snow by giving the last vertex a color of its own: white.

```

fColor = gs_in[0].color;
gl_Position = position + vec4(-0.2f, -0.2f, 0.0f, 0.0f); // 1:bottom-
left
EmitVertex();
gl_Position = position + vec4( 0.2f, -0.2f, 0.0f, 0.0f); // 2:bottom-
right
EmitVertex();
gl_Position = position + vec4(-0.2f, 0.2f, 0.0f, 0.0f); // 3:top-left

```



```
EmitVertex();
gl_Position = position + vec4( 0.2f, 0.2f, 0.0f, 0.0f); // 4:top-right
EmitVertex();
gl_Position = position + vec4( 0.0f, 0.4f, 0.0f, 0.0f); // 5:top
fColor = vec3(1.0f, 1.0f, 1.0f);
EmitVertex();
EndPrimitive();
```

The result now looks something like this:

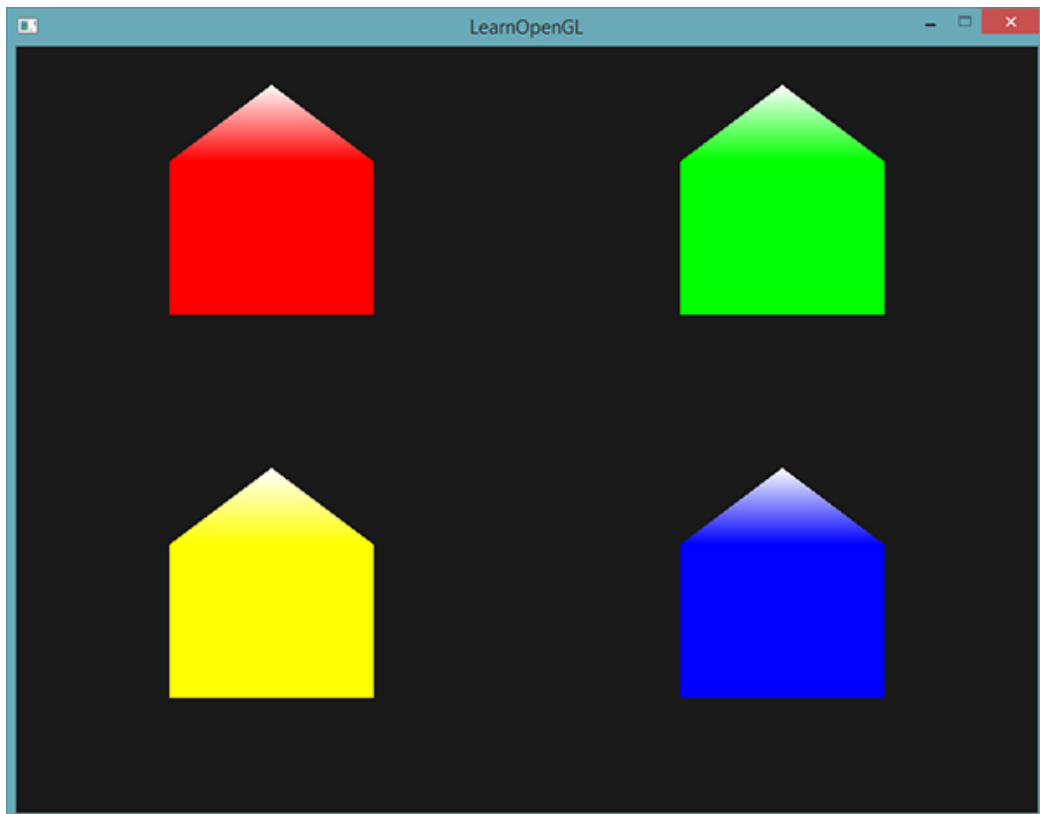

You can compare your source code with the OpenGL code [here](#) together with the [shaders](#) used.

You can see that with geometry shaders you can get pretty creative even with the simplest primitives. Because the shapes are generated dynamically on the ultra-fast hardware of your GPU this is a lot more efficient than defining these shapes yourself within vertex buffers. Geometry buffers are therefore a great tool for optimization on simple often-repeating shapes like cubes in a voxel world or grass leaves on a large outdoor field.

30.3 Exploding objects

While drawing houses is fun and all, it's not something we're going to use that much. That's why we're now going to take it up one notch and explode objects! That is something we're also probably not going to use that much either, but it does show you some of the powers of geometry shaders.

When we say *exploding* an object we're not actually going to blow up our precious bundled sets of vertices, but we're going to move each triangle along the direction of their normal vector over a small period of time. The effect is that the entire object's triangles seem to *explode* along the

direction of each of the triangle's normal vectors. The effect of exploding triangles on the nanosuit model looks a bit like this:

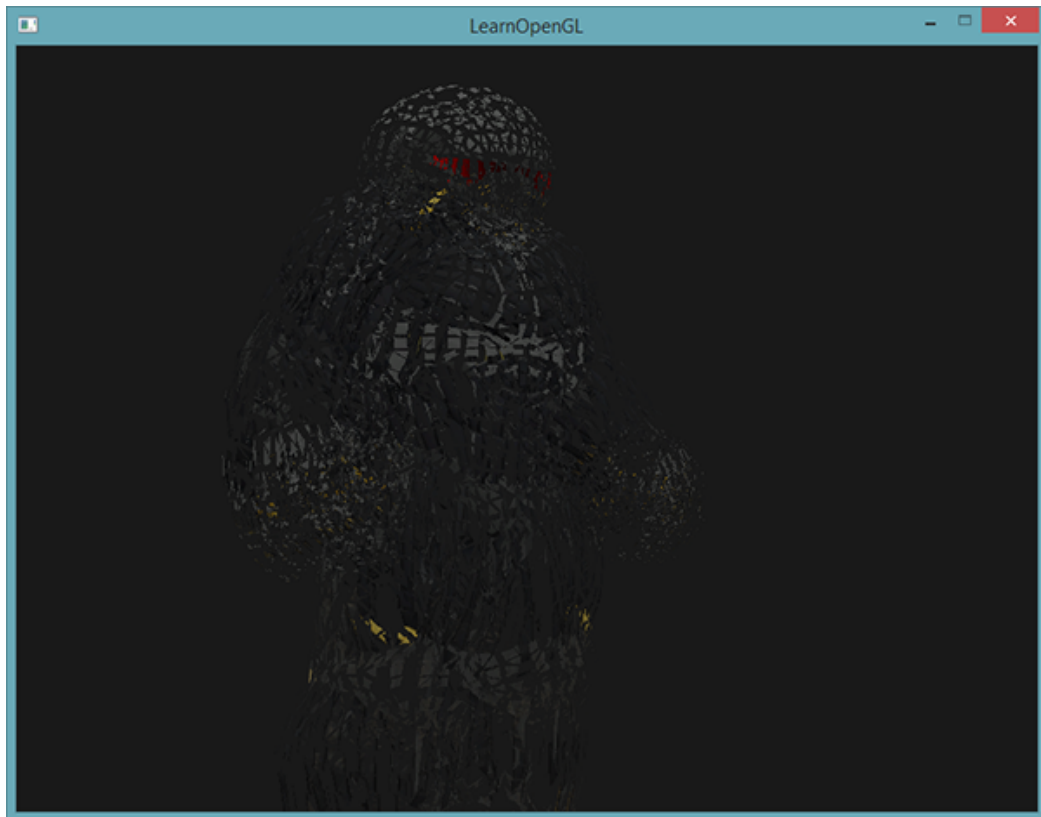

The great thing about such a geometry shader effect is that it works on all objects, regardless of their complexity.

Because we're going to translate each vertex into the direction of the triangle's normal vector we first need to calculate this normal vector. What we need to do is calculate a vector that is perpendicular to the surface of a triangle, using just the 3 vertices we have access to. You might remember from the [transformations](#) tutorial that we can retrieve a vector perpendicular to two other vectors using the **cross product**. If we were to retrieve two vectors **a** and **b** that are parallel to the surface of the triangle we can retrieve the normal vector by doing a cross product on those vectors. The following geometry shader function does exactly this to retrieve the normal vector using 3 input vertex coordinates:

```
vec3 GetNormal ()
{
    vec3 a = vec3(gl_in[0].gl_Position) - vec3(gl_in[1].gl_Position);
    vec3 b = vec3(gl_in[2].gl_Position) - vec3(gl_in[1].gl_Position);
    return normalize(cross(a, b));
}
```

Here we retrieve two vectors **a** and **b** that are parallel to the surface of the triangle using subtraction. Subtracting two vectors from each other results in a vector that is the difference of the two vectors and since all 3 points lie on the triangle plane, subtracting any of its vectors from each other results in a vector parallel to the plane. Do note that if we switched **a** and **b** in the **cross** function we'd get a normal vector that points in the opposite direction - order is important here!

Now that we know how to calculate a normal vector we can create an `explode` function that takes this normal vector along with a vertex position vector. The function returns a new vector that translates the position vector along the direction of the normal vector:

```
vec4 explode(vec4 position, vec3 normal)
{
    float magnitude = 2.0f;
    vec3 direction = normal * ((sin(time) + 1.0f) / 2.0f) * magnitude;
    return position + vec4(direction, 0.0f);
}
```

The function itself shouldn't be too complicated. The `sin` function receives a `time` variable as its argument that based on the time returns a value between -1.0 and 1.0 . Because we don't want to *implode* the object we transform the sin values to the $[0, 1]$ range. The resulting value is then multiplied by the `normal` vector and the resulting `direction` vector is added to the position vector.

The complete geometry shader for the `explode` effect while drawing a model loaded using our `model loader` then looks like this:

```
#version 330 core
layout (triangles) in;
layout (triangle_strip, max_vertices = 3) out;

in VS_OUT {
    vec2 texCoords;
} gs_in[];

out vec2 TexCoords;

uniform float time;

vec4 explode(vec4 position, vec3 normal) { ... }

vec3 GetNormal() { ... }

void main() {
    vec3 normal = GetNormal();

    gl_Position = explode(gl_in[0].gl_Position, normal);
    TexCoords = gs_in[0].texCoords;
    EmitVertex();
    gl_Position = explode(gl_in[1].gl_Position, normal);
    TexCoords = gs_in[1].texCoords;
    EmitVertex();
    gl_Position = explode(gl_in[2].gl_Position, normal);
    TexCoords = gs_in[2].texCoords;
    EmitVertex();
    EndPrimitive();
}
```

Note that we're also outputting the appropriate texture coordinates before emitting a vertex.

Also don't forget to actually set the `time` variable in your OpenGL code:

```
glUniform1f(glGetUniformLocation(shader.Program, "time"), glfwGetTime());
```

The result is a 3D model that seems to continually explode its vertices over time after which it returns to normal again. Although not exactly super useful, it does show you a more advanced use of the geometry shader. You can compare your source code with the complete source code [here](#) together with the [shaders](#) used.

30.4 Visualizing normal vectors

In this section we're going to give you an example of using the geometry shader that is actually useful: visualizing the normal vectors of any object. When programming lighting shaders you will eventually run into weird visual outputs of which the cause is hard to determine. A common cause of lighting errors is due to incorrect normal vectors caused by incorrectly loading vertex data, improperly specifying them as vertex attributes or incorrectly managing them in the shaders. What we want is some way to detect if the normal vectors we supplied are correct. A great way to determine if your normal vectors are correct is by visualizing them and it just so happens that the geometry shader is an extremely useful tool for this purpose.

The idea is as follows: we first draw the scene as normal without a geometry shader and then we draw the scene a second time, but this time only displaying normal vectors that we generate via a geometry shader. The geometry shader takes as input a triangle primitive and generates 3 lines from those in the direction of the normal vector - one normal vector for each vertex. In pseudocode it'll look something like this:

```
shader.Use();
DrawScene();
normalDisplayShader.Use();
DrawScene();
```

This time we're creating a geometry shader that uses the vertex normals supplied by the model instead of generating them ourselves. To accommodate for scaling and rotations (due to the view and model matrix) we'll transform the normals first with a normal matrix before transforming it to clip-space coordinates (geometry shader receives its position vectors as clip-space coordinates so we should also transform the normal vectors to the same space). This can all be done in the vertex shader:

```
#version 330 core
layout (location = 0) in vec3 position;
layout (location = 1) in vec3 normal;

out VS_OUT {
    vec3 normal;
} vs_out;

uniform mat4 projection;
uniform mat4 view;
uniform mat4 model;

void main()
{
    gl_Position = projection * view * model * vec4(position, 1.0f);
    mat3 normalMatrix = mat3(transpose(inverse(view * model)));
    vs_out.normal = normalize(vec3(projection * vec4(normalMatrix * normal,
        1.0)));
```

```
}
```

The transformed clip-space normal vector is then passed to the next shader stage via an interface block. The geometry shader then takes each vertex (with a position and a normal vector) and draws a normal vector from each position vector:

```
#version 330 core
layout (triangles) in;
layout (line_strip, max_vertices = 6) out;

in VS_OUT {
    vec3 normal;
} gs_in[];

const float MAGNITUDE = 0.4f;

void GenerateLine(int index)
{
    gl_Position = gl_in[index].gl_Position;
    EmitVertex();
    gl_Position = gl_in[index].gl_Position + vec4(gs_in[index].normal, 0.0f)
    * MAGNITUDE;
    EmitVertex();
    EndPrimitive();
}

void main()
{
    GenerateLine(0); // First vertex normal
    GenerateLine(1); // Second vertex normal
    GenerateLine(2); // Third vertex normal
}
```

The contents of geometry shaders like these should be self-explanatory by now. Note that we're multiplying the normal vector by a `MAGNITUDE` vector to restrain the size of the displayed normal vectors (otherwise they'd be a bit too large).

Since visualizing normals are mostly used for debugging purposes we can just display them as mono-colored lines (or super-fancy lines if you feel like it) with the help of the fragment shader:

```
#version 330 core
out vec4 color;

void main()
{
    color = vec4(1.0f, 1.0f, 0.0f, 1.0f);
}
```

Now rendering your model with normal shaders first and then with the special *normal-visualizing* shader you'll see something like this:

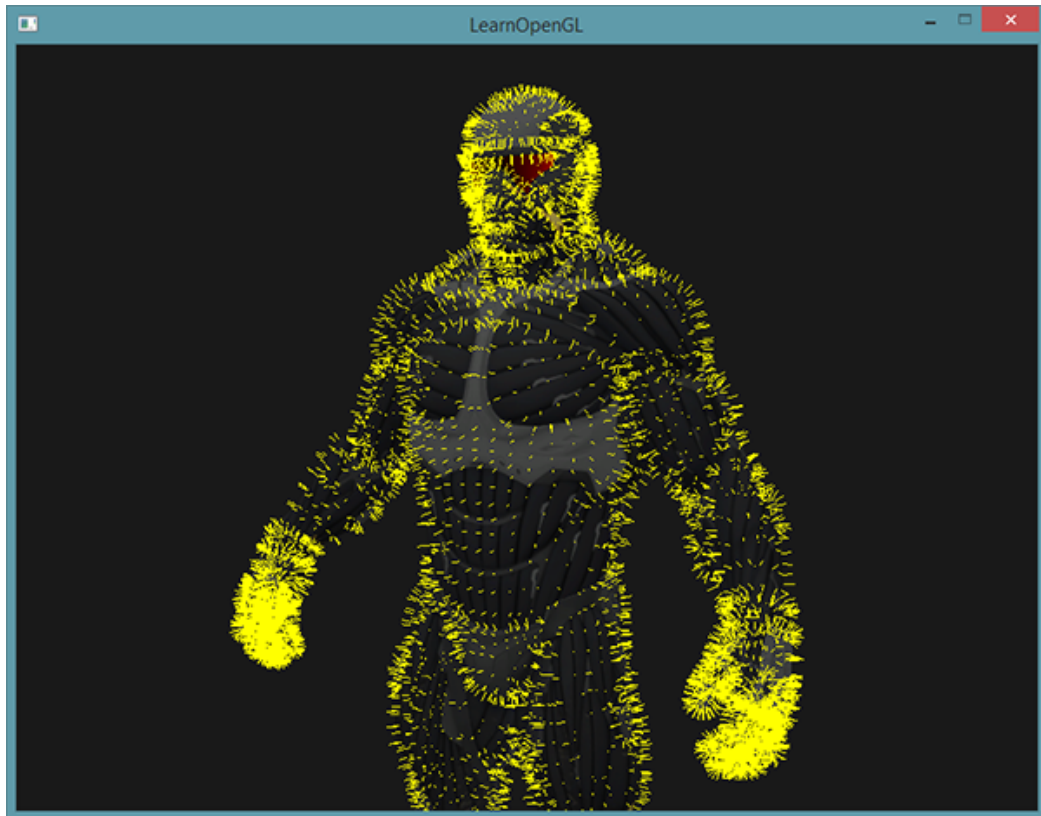

Apart from the fact that our nanosuit now looks like a hairy guy with kitchen mittens on, it gives us a really useful method for determining if the normal vectors of a model are indeed correct. You can imagine that geometry shaders like this are also frequently used for adding `fur` to objects.

You can find the OpenGL's source code [here](#) together with its normal-displaying [shaders](#).



31. Instancing

Say you have a scene where you're drawing a lot of models where most of these models contain the same set of vertex data, but with different world transformations. Think of a scene filled with grass leaves: each grass leaf is a small model consisting of only a few triangles. You'll probably want to draw quite a few of them and your scene might end up with thousands or maybe tens of thousands of grass leaves that you need to render each frame. Because each leaf consists of only a few triangles the leaf is rendered almost instantly, but all those thousands of render calls you'll have to make will drastically reduce performance.

If we were to actually render such a large amount of objects it will look a bit like this in code:

```
for(GLuint i = 0; i < amount_of_models_to_draw; i++)
{
    DoSomePreparations(); // bind VAO, bind Textures, set uniforms etc.
    glDrawArrays(GL_TRIANGLES, 0, amount_of_vertices);
}
```

When drawing many **instances** of your model like this you'll quickly reach a performance bottleneck because of the many drawing calls. Compared to rendering the actual vertices, telling the GPU to render your vertex data with functions like `glDrawArrays` or `glDrawElements` eats up quite some performance since OpenGL must make necessary preparations before it can draw your vertex data (like telling the GPU which buffer to read data from, where to find vertex attributes and all this over the relatively slow CPU to GPU bus). So even though rendering your vertices is super fast, giving your GPU the commands to render them isn't.

It would be much more convenient if we could send some data over to the GPU once and then tell OpenGL to draw multiple objects with a single drawing call using this data. Enter **instancing**.

Instancing is a technique where we draw many objects at once with a single render call, saving us all the CPU -> GPU communications each time we need to render an object; this only has to be done

once. To render using instancing all we need to do is change the render calls `glDrawArrays` and `glDrawElements` to `glDrawArraysInstanced` and `glDrawElementsInstanced` respectively. These *instanced* versions of the classic rendering functions take an extra parameter called the *instance count* that sets the number of instances we want to render. We thus sent all the required data to the GPU only once, and then tell the GPU how it should draw all these instances with a single call. The GPU then renders all these instances without having to continually communicate with the CPU.

By itself this function is a bit useless. Rendering the same object a thousand times is of no use to us since each of the rendered objects are rendered exactly the same and thus also at the same location; we would only see one object! For this reason GLSL embedded another built-in variable in the vertex shader called `gl_InstanceID`.

When drawing via one of the instanced rendering calls, `gl_InstanceID` is incremented for each instance being rendered starting from 0. If we were to render the 43th instance for example, `gl_InstanceID` would have the value 42 in the vertex shader. Having a unique value per instance means we could now for example index into a large array of position values to position each instance at a different location in the world.

To get a feel for instanced drawing we're going to demonstrate a simple example that renders a hundred 2D quads in normalized device coordinates with just one render call. We accomplish this by adding a small offset to each instanced quad by indexing a uniform array of 100 offset vectors. The result is a neatly organized grid of quads that fill the entire window:

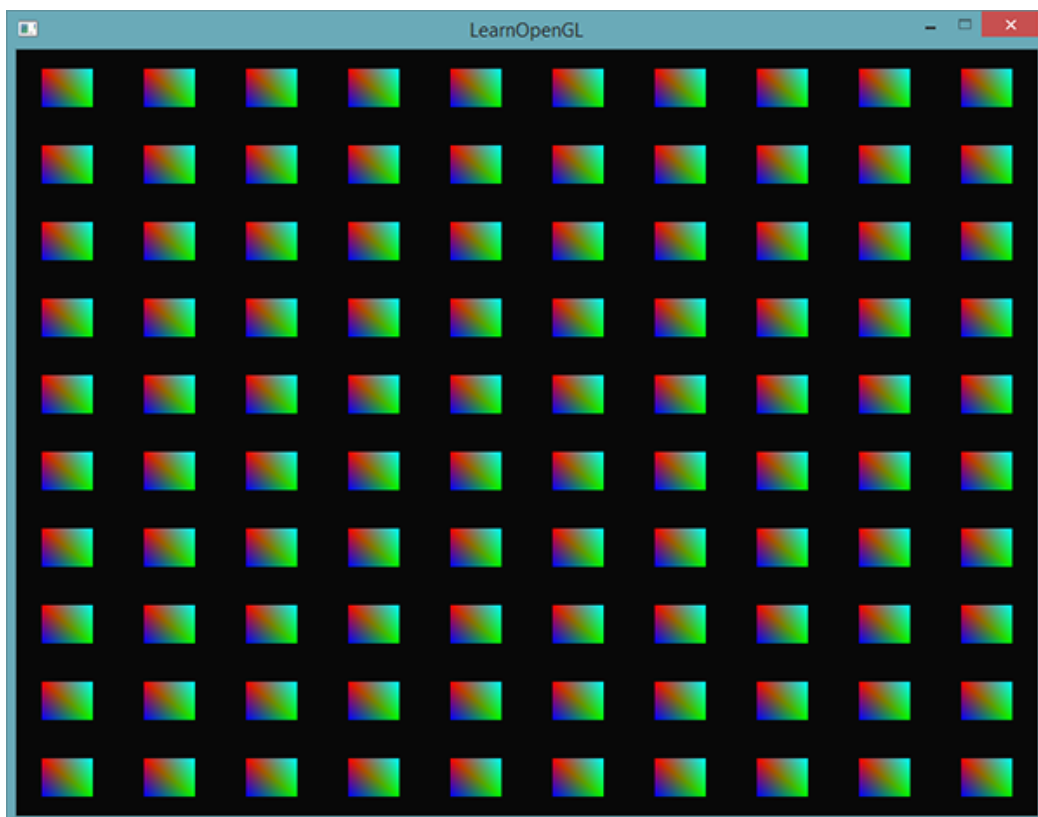

Each quad consists of 2 triangles with a total of 6 vertices. Each vertex contains a 2D NDC position vector and a color vector. Below is the vertex data used for this example - the triangles are

quite small to properly fit the screen in large quantities:

```
GLfloat quadVertices[] = {
    // Positions    // Colors
    -0.05f, 0.05f, 1.0f, 0.0f, 0.0f,
     0.05f, -0.05f, 0.0f, 1.0f, 0.0f,
    -0.05f, -0.05f, 0.0f, 0.0f, 1.0f,

    -0.05f, 0.05f, 1.0f, 0.0f, 0.0f,
     0.05f, -0.05f, 0.0f, 1.0f, 0.0f,
     0.05f, 0.05f, 0.0f, 1.0f, 1.0f
};
```

The colors of the quads are accomplished with the fragment shader that receives a forwarded color vector from the vertex shader and sets it as its color output:

```
#version 330 core
in vec3 fColor;
out vec4 color;

void main()
{
    color = vec4(fColor, 1.0f);
}
```

Nothing new so far, but at the vertex shader it's starting to get interesting:

```
#version 330 core
layout (location = 0) in vec2 position;
layout (location = 1) in vec3 color;

out vec3 fColor;

uniform vec2 offsets[100];

void main()
{
    vec2 offset = offsets[gl_InstanceID];
    gl_Position = vec4(position + offset, 0.0f, 1.0f);
    fColor = color;
}
```

Here we defined a uniform array called `offsets` that contain a total of 100 offset vectors. Within the vertex shader we then retrieve an offset vector for each instance by indexing the `offsets` array using `gl_InstanceID`. If we were to draw 100 quads using instanced drawing we'd get 100 quads located at different positions with just this vertex shader.

We do need to actually set the offset positions that we calculate in a nested for-loop before we enter the game loop:

```
glm::vec2 translations[100];
int index = 0;
GLfloat offset = 0.1f;
for(GLint y = -10; y < 10; y += 2)
{
    for(GLint x = -10; x < 10; x += 2)
```

```

{
    glm::vec2 translation;
    translation.x = (GLfloat)x / 10.0f + offset;
    translation.y = (GLfloat)y / 10.0f + offset;
    translations[index++] = translation;
}
}

```

Here we create a set of 100 translation vectors that contains a translation vector for all positions in a 10x10 grid. Aside from generating the `translations` array we'd also need to transfer the data to the vertex shader's uniform array:

```

shader.Use();
for(GLuint i = 0; i < 100; i++)
{
    stringstream ss;
    string index;
    ss << i;
    index = ss.str();
    GLint location = glGetUniformLocation(shader.Program, ("offsets[" +
    index + "]" ).c_str());
    glUniform2f(location, translations[i].x, translations[i].y);
}

```

Within this snippet of code we transform the for-loop counter `i` to a `string` that we then use to dynamically create a location string for querying the uniform location. For each item in the `offsets` uniform array we then set the corresponding translation vector.

Now that all the preparations are finished we can start rendering the quads. To draw via instanced rendering we call `glDrawArraysInstanced` or `glDrawElementsInstanced`. Since we're not using an element index buffer we're going to call the `glDrawArrays` version:

```

glBindVertexArray(quadVAO);
glDrawArraysInstanced(GL_TRIANGLES, 0, 6, 100);
glBindVertexArray(0);

```

The parameters of `glDrawArraysInstanced` are exactly the same as `glDrawArrays` except the last parameter that sets the number of instances we want to draw. Since we want to display 100 quads in a 10x10 grid we set it equal to 100. Running the code should now give you the familiar image of 100 colorful quads.

31.1 Instanced arrays

While the previous implementation works fine for this specific use case, whenever we are rendering a lot more than 100 instances (which is quite common) we will eventually hit a `limit` on the amount of uniform data we can send to the shaders. Another alternative is called `instanced arrays` that is defined as a vertex attribute (allowing us to store much more data) that is only updated whenever the vertex shader renders a new instance.

With vertex attributes, each run of the vertex shader will cause GLSL to retrieve the next set of vertex attributes that belong to the current vertex. When defining a vertex attribute as an instanced array however, the vertex shader only updates the content of the vertex attribute per instance instead

of per vertex. This allows us to use the standard vertex attributes for data per vertex and use the instanced array for storing data that is unique per instance.

To give you an example of an instanced array we're going to take the previous example and represent the offset uniform array as an instanced array. We'll have to update the vertex shader by adding another vertex attribute:

```
#version 330 core
layout (location = 0) in vec2 position;
layout (location = 1) in vec3 color;
layout (location = 2) in vec2 offset;

out vec3 fColor;

void main()
{
    gl_Position = vec4(position + offset, 0.0f, 1.0f);
    fColor = color;
}
```

We no longer use `gl_InstanceID` and can directly use the `offset` attribute without first indexing into a large uniform array.

Because an instanced array is a vertex attribute, just like the `position` and `color` variables, we also need to store its content in a vertex buffer object and configure its attribute pointer. We're first going to store the `translations` array (from the previous section) in a new buffer object:

```
GLuint instanceVBO;
glGenBuffers(1, &instanceVBO);
glBindBuffer(GL_ARRAY_BUFFER, instanceVBO);
glBufferData(GL_ARRAY_BUFFER, sizeof(glm::vec2) * 100, &translations[0],
             GL_STATIC_DRAW);
glBindBuffer(GL_ARRAY_BUFFER, 0);
```

Then we also need to set its vertex attribute pointer and enable the vertex attribute:

```
glEnableVertexAttribArray(2);
glBindBuffer(GL_ARRAY_BUFFER, instanceVBO);
glVertexAttribPointer(2, 2, GL_FLOAT, GL_FALSE, 2 * sizeof(GLfloat), (
    GLvoid*)0);
glBindBuffer(GL_ARRAY_BUFFER, 0);
glVertexAttribDivisor(2, 1);
```

What makes this code interesting is the last line where we call `glVertexAttribDivisor`. This function tells OpenGL **when** to update the content of a vertex attribute to the next element. Its first parameter is the vertex attribute in question and the second parameter the **attribute divisor**. By default the attribute divisor is 0 which tells OpenGL to update the content of the vertex attribute each iteration of the vertex shader. By setting this attribute to 1 we're telling OpenGL that we want to update the content of the vertex attribute when we start to render a new instance. By setting it to 2 we'd update the content every 2 instances and so on. By setting the attribute divisor to 1 we're effectively telling OpenGL that the vertex attribute at attribute location 2 is an instanced array.

If we now were to render the quads again using `glDrawArraysInstanced` we'd get the following output:

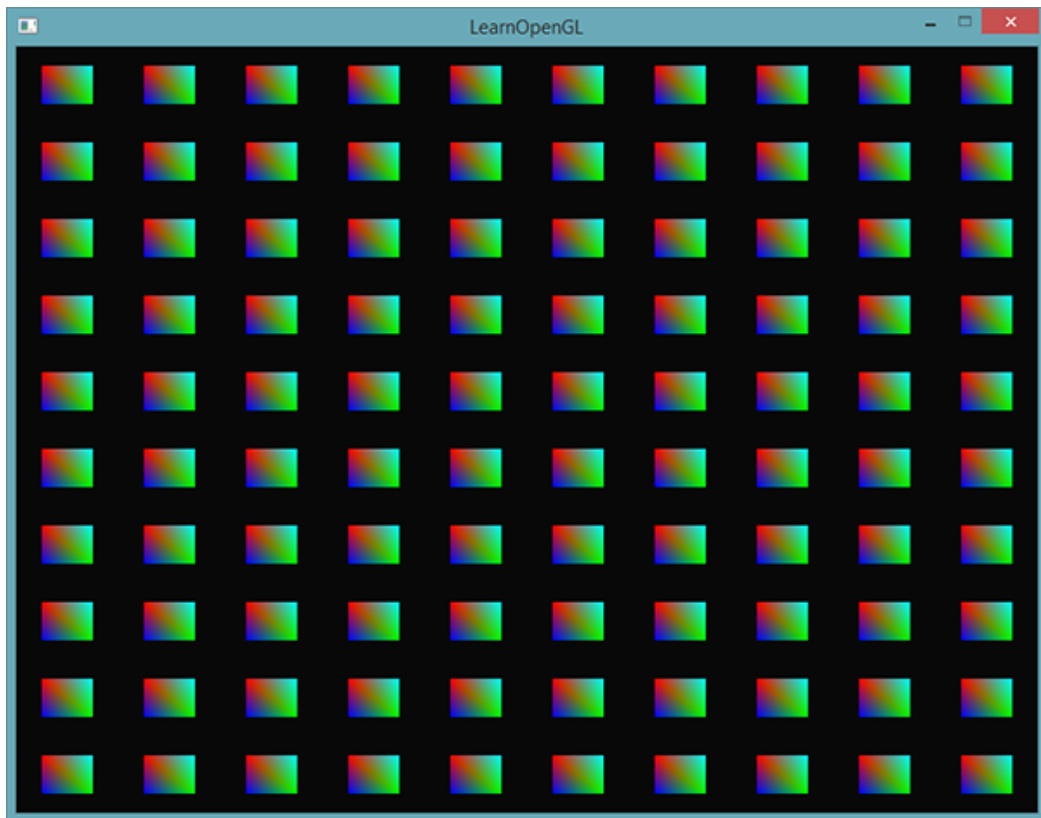

This is exactly the same as the previous example, but this time accomplished using instanced arrays, which allows us to pass a lot more data (as much as memory allows us to) to the vertex shader for instanced drawing.

For fun we could also slowly downscale each quad from top-right to bottom-left using `gl_InstanceID` again, because why not?

```
void main()
{
    vec2 pos = position * (gl_InstanceID / 100.0f);
    gl_Position = vec4(pos + offset, 0.0f, 1.0f);
    fColor = color;
}
```

The result is that the first instances of the quads are drawn extremely small and the further we're in the process of drawing the instances, the closer `gl_InstanceID` gets to 100 and thus the more the quads regain their original size. It's perfectly legal to use instanced arrays together with `gl_InstanceID` like this.

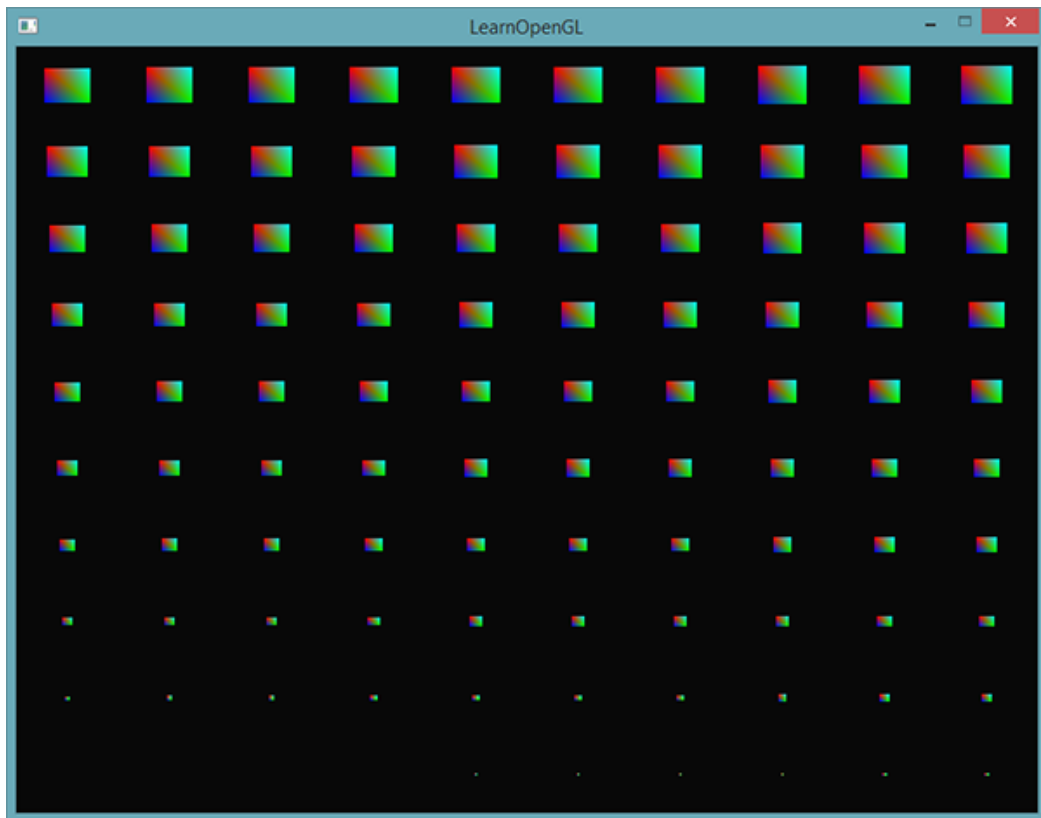

If you're still a bit unsure about how instanced rendering works or want to see how everything fits together you can find the full source code of the application [here](#).

While fun and all, these examples aren't really good examples of instancing. Yes, they do give you an easy overview of how instancing works, but instancing is extremely useful when drawing an enormous amount of similar objects which we haven't really been doing so far. For that reason we're going to venture into space in the next section to see the real power of instanced rendering.

31.2 An asteroid field

Imagine a scene where we have one large planet that's at the center of a large asteroid ring. Such an asteroid ring could contain thousands or tens of thousands of rock formations and quickly becomes un-renderable on any decent graphics card. This scenario proves itself particularly useful for instanced rendering, since all the asteroids can be represented using a single model. Each single asteroid then contains minor variations using a transformation matrix unique to each asteroid.

To demonstrate the impact of instanced rendering we're first going to render a scene of asteroids flying around a planet *without* instanced rendering. The scene will contain a large planet model that can be downloaded from [here](#) and a large set of asteroid rocks that we properly position around the planet. The asteroid rock model can be downloaded [here](#).

Within the code samples we load the models using the model loader we've previously defined in the [model loading](#) tutorials.

To achieve the effect we're looking for we'll be generating a transformation matrix for each

asteroid that we'll use as their model matrix. The transformation matrix is created by first translating the rock somewhere in the asteroid ring - we'll also add a small random displacement value to this offset to make the ring look more natural. Then we apply a random scale and a random rotation around a rotation vector. The result is a transformation matrix that transforms each asteroid somewhere around the planet while also giving it a more natural and unique look compared to other asteroids. The result is a ring full of asteroids where each asteroid looks different to the other.

```

GLuint amount = 1000;
glm::mat4* modelMatrices;
modelMatrices = new glm::mat4[amount];
srand(glFWGetTime()); // initialize random seed
GLfloat radius = 50.0;
GLfloat offset = 2.5f;
for(GLuint i = 0; i < amount; i++)
{
    glm::mat4 model;
    // 1. Translation: displace along circle with 'radius' in range [-
    offset, offset]
    GLfloat angle = (GLfloat)i / (GLfloat)amount * 360.0f;
    GLfloat displacement = (rand() \% (GLint)(2 * offset * 100)) / 100.0f -
    offset;
    GLfloat x = sin(angle) * radius + displacement;
    displacement = (rand() \% (GLint)(2 * offset * 100)) / 100.0f - offset;
    GLfloat y = displacement * 0.4f; // y value has smaller displacement
    displacement = (rand() \% (GLint)(2 * offset * 100)) / 100.0f - offset;
    GLfloat z = cos(angle) * radius + displacement;
    model = glm::translate(model, glm::vec3(x, y, z));
    // 2. Scale: Scale between 0.05 and 0.25f
    GLfloat scale = (rand() \% 20) / 100.0f + 0.05;
    model = glm::scale(model, glm::vec3(scale));
    // 3. Rotation: add random rotation around a (semi)randomly picked
    rotation axis vector
    GLfloat rotAngle = (rand() \% 360);
    model = glm::rotate(model, rotAngle, glm::vec3(0.4f, 0.6f, 0.8f));
    // 4. Now add to list of matrices
    modelMatrices[i] = model;
}

```

This piece of code might look a little daunting, but we basically transform the x and z position of the asteroid along a circle with a radius defined by `radius` and randomly displace each asteroid a little around the circle by `-offset` and `offset`. We give the y displacement less of an impact to create a more flat asteroid ring. Then we apply scale and rotation transformations and store the resulting transformation matrix in `modelMatrices` that is of size `amount`. Here we generate a total of 1000 model matrices, one per asteroid.

After loading the planet and rock models and compiling a set of shaders, the rendering code then looks a bit like this:

```

// Draw Planet
shader.Use();
glm::mat4 model;
model = glm::translate(model, glm::vec3(0.0f, -5.0f, 0.0f));
model = glm::scale(model, glm::vec3(4.0f, 4.0f, 4.0f));
glUniformMatrix4fv(modelLoc, 1, GL_FALSE, glm::value_ptr(model));
planet.Draw(shader);

```

```
// Draw Asteroid circle
for(GLuint i = 0; i < amount; i++)
{
    glUniformMatrix4fv(modelLoc, 1, GL_FALSE, glm::value_ptr(modelMatrices[
    i]));
    rock.Draw(shader);
}
```

First we draw the planet model that we translate and scale a bit to accommodate to the scene and then we draw a number of rock models equal to the `amount` of transformations we calculated. Before we draw each rock however, we first set the corresponding model transformation matrix within the shader.

The result is then a space-like scene where we can see a natural-looking asteroid ring around a planet:

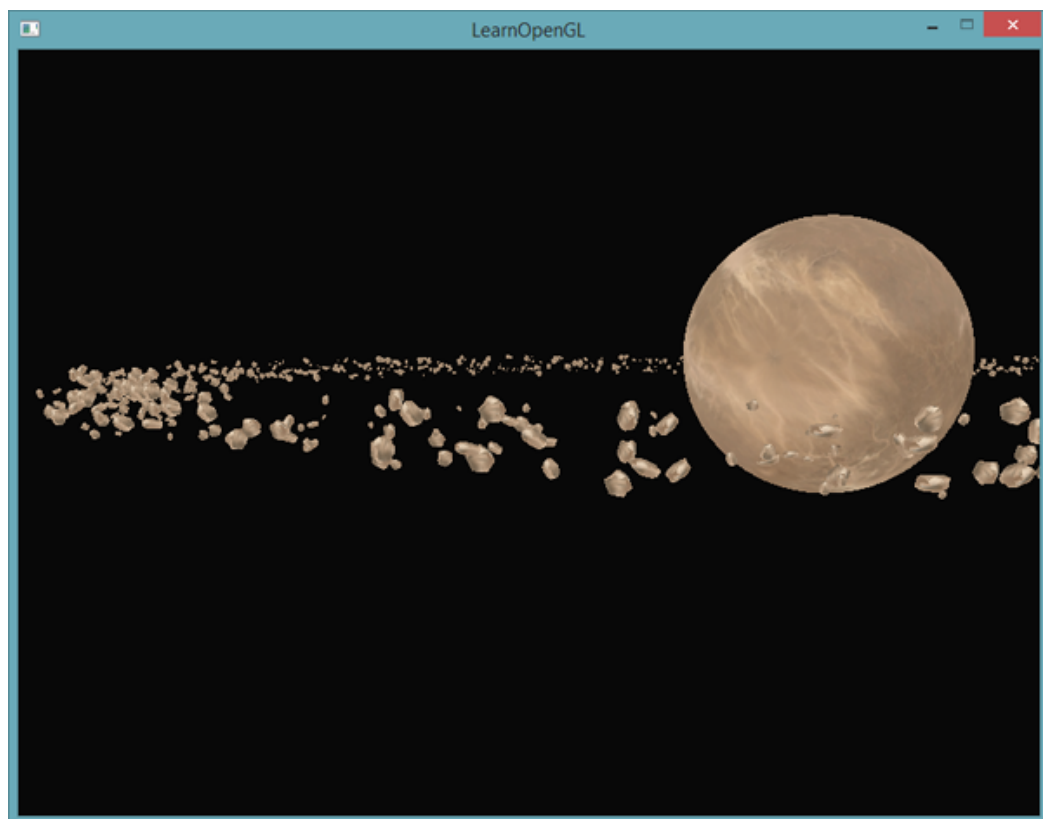

This scene contains a total of 1001 rendering calls per frame of which 1000 are of the rock model. You can find the source code for this scene [here](#) together with the [vertex](#) and [fragment](#) shader.

As soon as we start to increase this number we will quickly notice that the scene stops running smoothly and the number of frames we're able to render per second reduces drastically. As soon as we set `amount` to 2000 the scene already becomes so slow, it's difficult to move around.

Let's now try to render the same scene, but this time using instanced rendering. We first need to adapt the vertex shader a little:

```
#version 330 core
layout (location = 0) in vec3 position;
layout (location = 2) in vec2 texCoords;
layout (location = 3) in mat4 instanceMatrix;

out vec2 TexCoords;

uniform mat4 projection;
uniform mat4 view;

void main()
{
    gl_Position = projection * view * instanceMatrix * vec4(position, 1.0f)
    ;
    TexCoords = texCoords;
}
```

We're no longer using a model uniform variable, but instead declare a `mat4` as a vertex attribute so we can store an instanced array of transformation matrices. However, when we declare a datatype as a vertex attribute that is greater than a `vec4` things work a bit differently. The maximum amount of data allowed as a vertex attribute is equal to a `vec4`. Because a `mat4` is basically 4 `vec4`s, we have to reserve 4 vertex attributes for this specific matrix. Because we assigned it a location of 3, the columns of the matrix will have vertex attribute locations of 3, 4, 5 and 6.

We then have to set each of the attribute pointers of those 4 vertex attributes and configure them as instanced arrays:

```
for(GLuint i = 0; i < rock.meshes.size(); i++)
{
    GLuint VAO = rock.meshes[i].VAO;
    // Vertex Buffer Object
    GLuint buffer;
    glBindVertexArray(VAO);
    glGenBuffers(1, &buffer);
    glBindBuffer(GL_ARRAY_BUFFER, buffer);
    glBufferData(GL_ARRAY_BUFFER, amount * sizeof(glm::mat4), &
    modelMatrices[0], GL_STATIC_DRAW);
    // Vertex Attributes
    GLsizei vec4Size = sizeof(glm::vec4);
    glEnableVertexAttribArray(3);
    glVertexAttribPointer(3, 4, GL_FLOAT, GL_FALSE, 4 * vec4Size, (GLvoid*)
    0);
    glEnableVertexAttribArray(4);
    glVertexAttribPointer(4, 4, GL_FLOAT, GL_FALSE, 4 * vec4Size, (GLvoid*)
    (vec4Size));
    glEnableVertexAttribArray(5);
    glVertexAttribPointer(5, 4, GL_FLOAT, GL_FALSE, 4 * vec4Size, (GLvoid*)
    (2 * vec4Size));
    glEnableVertexAttribArray(6);
    glVertexAttribPointer(6, 4, GL_FLOAT, GL_FALSE, 4 * vec4Size, (GLvoid*)
    (3 * vec4Size));

    glVertexAttribDivisor(3, 1);
    glVertexAttribDivisor(4, 1);
    glVertexAttribDivisor(5, 1);
    glVertexAttribDivisor(6, 1);

    glBindVertexArray(0);
}
```



```
}
```

Note that we cheated a little by declaring the `VAO` variable of the `Mesh` as a public variable instead of a private variable so we could access its vertex array object. This is not the cleanest solution, but just a simple modification to suit this tutorial. Aside from the little hack, this code should be clear. We're basically declaring how OpenGL should interpret the buffer for each of the matrix's vertex attributes and that each of those vertex attributes is an instanced array.

Next we take the `VAO` of the mesh(es) again and this time draw using `glDrawElementsInstanced`:

```
// Draw meteorites
instanceShader.Use();
for(GLuint i = 0; i < rock.meshes.size(); i++)
{
    glBindVertexArray(rock.meshes[i].VAO);
    glDrawElementsInstanced(
        GL_TRIANGLES, rock.meshes[i].vertices.size(), GL_UNSIGNED_INT, 0,
        amount
    );
    glBindVertexArray(0);
}
```

Here we draw the same `amount` of asteroids as the earlier example, but this time using instanced rendering. The results should be similar, but you'll start to really see the effect of instanced rendering when we start to increase this `amount` variable. Without instanced rendering we were able to smoothly render around 1000 to 1500 asteroids. With instanced rendering we can now set this value to 100000 that, with the rock model having 576 vertices, equals around 57 million vertices drawn each frame without any performance drops!

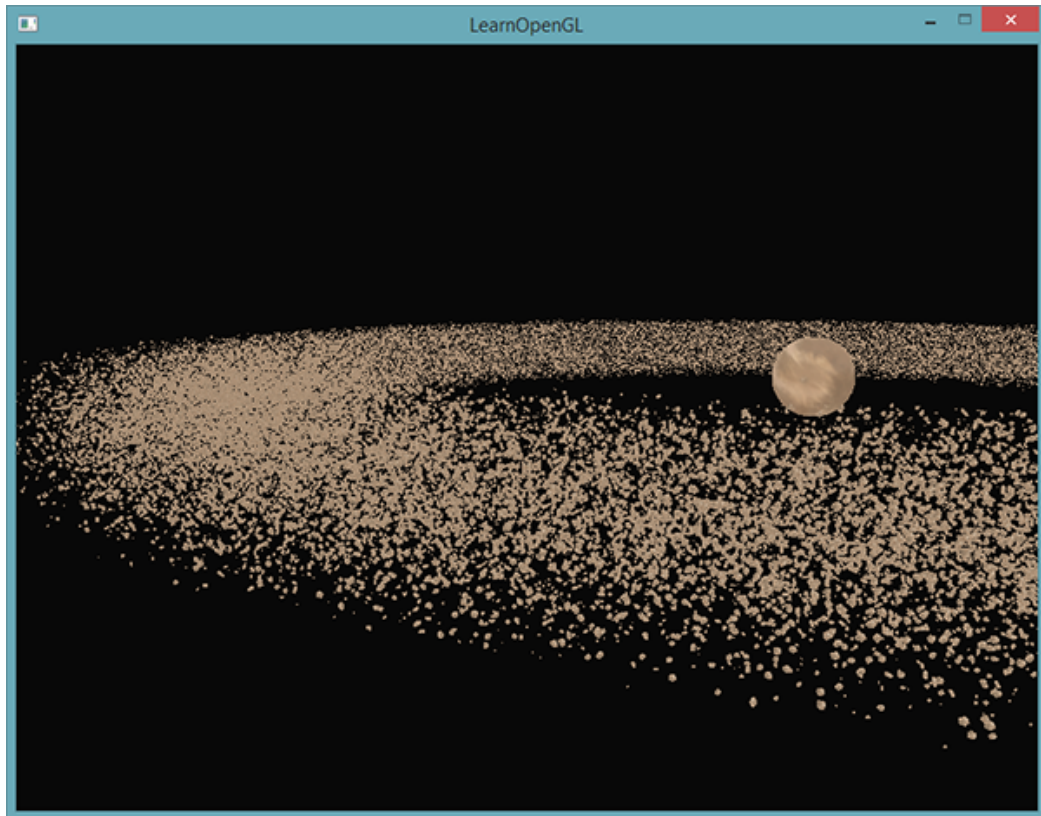

This image was rendered with 100000 asteroids with a radius of $150.0f$ and an offset equal to $25.0f$. You can find the source code of the instanced rendering demo [here](#).

On different machines an asteroid count of 100000 might be a bit too high, so try tweaking the values till you reach an acceptable framerate.

As you can see, with the right type of environments instanced rendering can make an enormous difference to the rendering capabilities of your graphics card. For this reason, instanced rendering is commonly used for grass, flora, particles and scenes like this - basically any scene with many repeating shapes can benefit from instanced rendering.

32. Anti Aliasing

Somewhere in your adventurous rendering journey you probably came across some jagged saw-like patterns along the edges of your models. The reason these **jagged edges** appear is due to how the rasterizer transforms the vertex data into actual fragments behind the scene. An example of what these jagged edges look like can already be seen when drawing a simple cube:

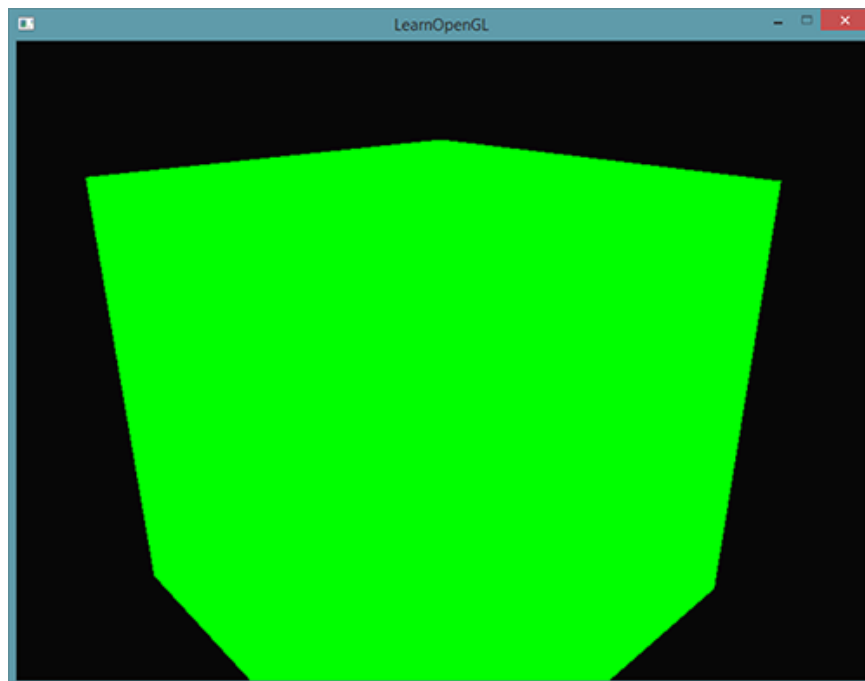

While not immediately visible, if you take a closer look at the edges of the cube you'll see a jagged pattern. If we zoom in you'd see the following:



This is clearly not something we want in a final version of an application. This effect, of clearly seeing the pixel formations an edge is composed of, is called **aliasing**. There are quite a few techniques out there called **anti-aliasing** techniques that fight exactly this aliasing behavior to produce more *smooth* edges.

At first we had a technique called **super sample anti-aliasing** (SSAA) that temporarily used a much higher resolution to render the scene in (super sampling) and when the visual output is updated in the framebuffer, the resolution was downsampled back to the normal resolution. This *extra* resolution was used to prevent these jagged edges. While it did provide us with a solution to the aliasing problem, it came with a major performance drawback since we had to draw a lot more fragments than usual. This technique therefore only had a short glory moment.

This technique did give birth to a more modern technique called **multisample anti-aliasing** or MSAA that borrows from the concepts behind SSAA while implementing a much more efficient approach. In this tutorial we'll be extensively discussing this MSAA technique that is built-in in OpenGL.

32.1 Multisampling

To understand what multisampling is and how it works into solving the aliasing problem we first need to delve a bit further into the inner workings of OpenGL's rasterizer.

The rasterizer is the combination of all algorithms and processes that sit between your final processed vertices and the fragment shader. The rasterizer takes all vertices belonging to a single primitive and transforms this to a set of fragments. Vertex coordinates can theoretically have any coordinate, but fragments can't since they are bound by the resolution of your window. There will almost never be a one-on-one mapping between vertex coordinates and fragments, so the rasterizer has to determine in some way at what fragment/screen-coordinate each specific vertex will end up at.

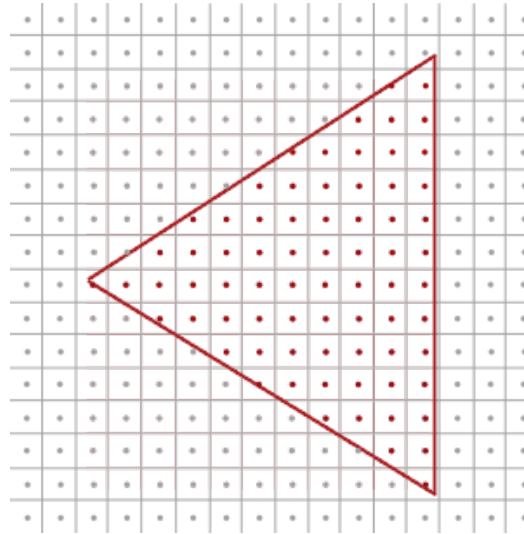

Here we see a grid of screen pixels where the center of each pixel contains a **sample point** that is used to determine if a pixel is covered by the triangle. The red sample points are covered by the triangle and a fragment will be generated for that covered pixel. Even though some parts of the triangle edges still enter certain screen pixels, the pixel's sample point is not covered by the inside of the triangle so this pixel won't be influenced by any fragment shader.

You can probably already figure out the origin of aliasing right now. The complete rendered version of the triangle would look like this on your screen:

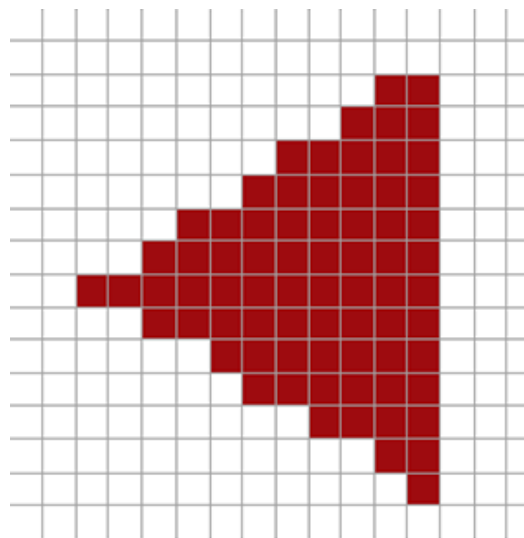

Due to the limited amount of screen pixels, some pixels will be rendered along an edge and some won't. The result is that we're rendering primitives with non-smooth edges giving rise to the jagged edges we've seen before.

What multisampling does is not use a single sampling point for determining coverage of the triangle, but use multiple sample points (guess where it got its name from). Instead of a single sample point at the center of each pixel we're going to place 4 **subsamples** in a general pattern and use those to determine pixel coverage. This does mean that the size of the color buffer is also increased by the number of subsamples we're using per pixel.

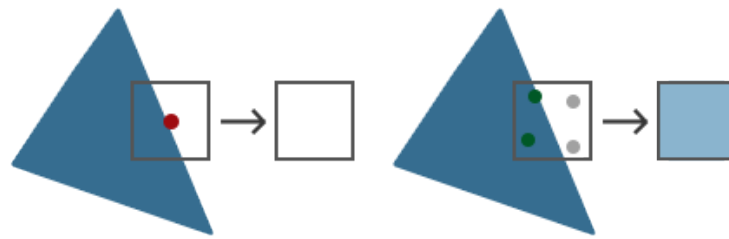

The left side of the image shows how we would normally determine the coverage of a triangle. This specific pixel won't run a fragment shader (and thus remains blank) since its sample point wasn't covered by the triangle. The right side of the image shows a multisampled version where each pixel contains 4 sample points. Here we can see that only 2 of the sample points cover the triangle.

The amount of sample points can be any number we'd like with more samples giving us better coverage precision.

This is where multisampling becomes interesting. We determined that 2 subsamples were covered by the triangle so the next step is to determine a color for this specific pixel. Our initial guess would be that we run the fragment shader for each covered subsample and later average the colors of each subsample per pixel. In this case we'd run the fragment shader twice on the interpolated vertex data at each subsample and store the resulting color in those sample points. This is (fortunately) **not** how it works, because this basically means we need to run a lot more fragment shaders than without multisampling, drastically reducing performance.

How MSAA really works is that the fragment shader is only run **once** per pixel (for each primitive) regardless of how many subsamples the triangle covers. The fragment shader is run with the vertex data interpolated to the **center** of the pixel and the resulting color is then stored inside each of the covered subsamples. Once the color buffer's subsamples are filled with all the colors of the primitives we've rendered, all these colors are then averaged per pixel resulting in a single color per pixel. Because only two of the 4 samples were covered in the previous image, the color of the pixel was averaged with the triangle's color and the color stored at the other 2 sample points (in this case: the clear color) resulting in a light blue-ish color.

The result is a color buffer where all the primitive edges now produce a smoother pattern. Let's see what multisampling looks like when we again determine the coverage of the earlier triangle:

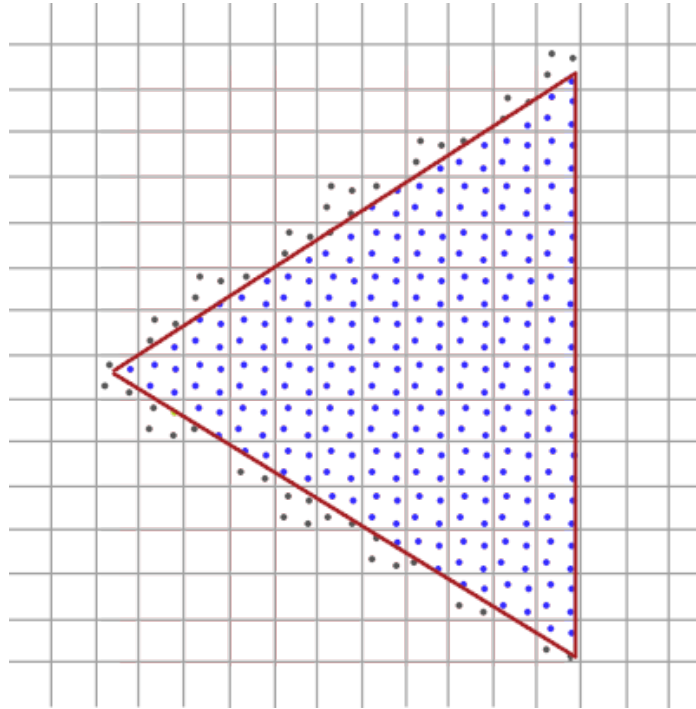

Here each pixel contains 4 subsamples (the irrelevant samples were hidden) where the blue subsamples are covered by the triangle and the gray sample points aren't. Within the inner region of the triangle all pixels will run the fragment shader once where its color output is stored in all 4 subsamples. At the edges of the triangle not all subsamples will be covered so the result of the fragment shader is only stored at some subsamples. Based on the amount of subsamples covered, the resulting pixel color is determined by the triangle color and the other subsample's stored colors.

Basically, the more sample points are covered by the triangle, the more the eventual pixel color is that of the triangle. If we then fill the pixel colors just like we did earlier with the non-multisampled triangle we get the following image:

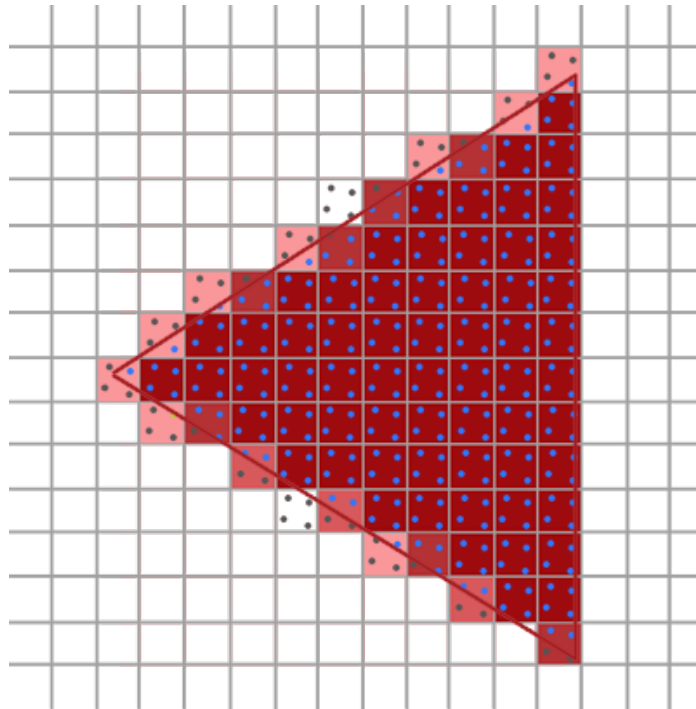

For each pixel, the less subsamples are part of the triangle, the less it takes the color of the triangle as you can see in the image. The hard edges of the triangle are now surrounded by colors slightly lighter than the actual edge color, which causes the edge to appear smooth when viewed from a distance.

Not only color values are affected by the multisampling, but also the depth and stencil test now make use of the multiple sample points. For depth testing, the vertex's depth value is interpolated to each subsample before running the depth test and for stencil testing we store stencil values per subsample, instead of per pixel. This does mean that the size of the depth and stencil buffer are now also increased by the amount of subsamples per pixel.

What we've discussed so far is a basic overview of how multisampled anti-aliasing works behind the scenes. The actual logic behind the rasterizer is a bit more complicated than we've discussed here, but you should be able to understand the concept and logic behind multisampled anti-aliasing now.

32.2 MSAA in OpenGL

If we want to use MSAA in OpenGL we need to use a color buffer that is able to store more than one color value per pixel (since multisampling requires us to store a color per sample point). We thus need a new type of buffer that can store a given amount of multisamples and this is called a [multisample buffer](#).

Most windowing systems are able to provide us a multisample buffer instead of a default color buffer. GLFW also gives us this functionality and all we need to do is *hint* GLFW that we'd like to use a multisample buffer with N samples instead of a normal color buffer by calling `glfwWindowHint` before creating the window:



```
glfwWindowHint(GLFW_SAMPLES, 4);
```

When we now call `glfwCreateWindow` the rendering window is created, this time with a color buffer containing 4 subsamples per screen coordinate. GLFW also automatically creates a depth and stencil buffer with 4 subsamples per pixel. This does mean that the size of all the buffers is increased by 4.

Now that we asked GLFW for multisampled buffers we need to enable multisampling by calling `glEnable` and enabling `GL_MULTISAMPLE`. On most OpenGL drivers, multisampling is enabled by default so this call is then a bit redundant, but it's usually a good idea to enable it anyways. This way all OpenGL implementations have multisampling enabled.

```
glEnable(GL_MULTISAMPLE);
```

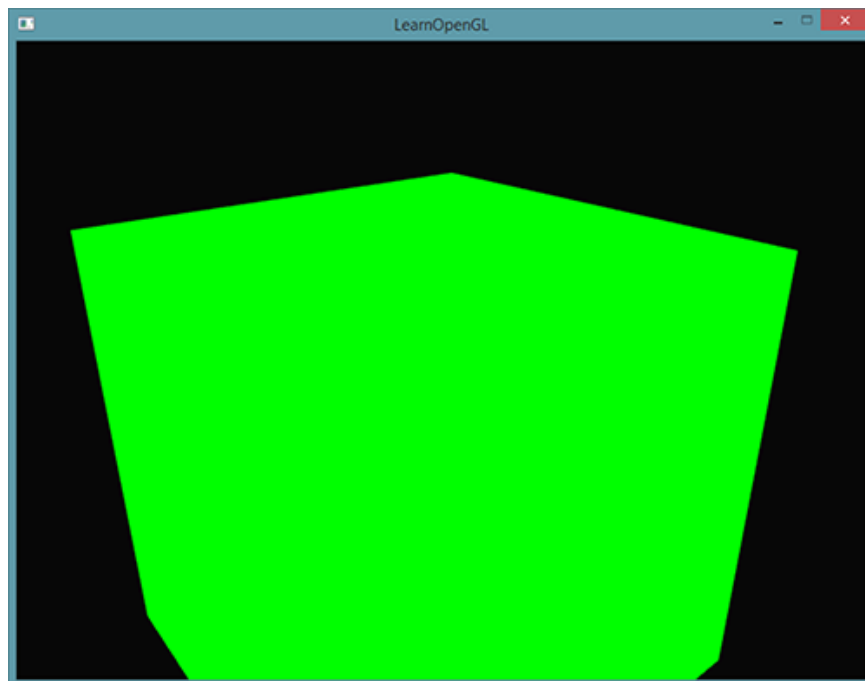
Once the default framebuffer has multisampled buffer attachments, all we need to do to enable multisampling is just call `glEnable` and we're done. Because the actual multisampling algorithms are implemented in the rasterizer in your OpenGL drivers there's not much else we need to do. If we now were to render the green cube from the start of this tutorial we should see much smoother edges:



This container does indeed look a lot smoother and the same will apply for any other object you're drawing in your scene. You can find the source code for this simple example [here](#).

32.3 Off-screen MSAA

Because GLFW takes care of creating the multisampled buffers, enabling MSAA is quite easy. If we want to use our own framebuffers however, for some off-screen rendering, we have to generate the multisampled buffers ourselves; now we do need to take care of creating multisampled buffers.

There are two ways we can create multisampled buffers to act as attachments for framebuffers: texture attachments and renderbuffer attachments, similar to normal attachments like we've discussed in the [framebuffers](#) tutorial.

32.3.1 Multisampled texture attachments

To create a texture that supports storage of multiple sample points we use `glTexImage2DMultisample` instead of `glTexImage2D` that accepts `GL_TEXTURE_2D_MULTISAMPLE` as its texture target:

```
glBindTexture(GL_TEXTURE_2D_MULTISAMPLE, tex);
glTexImage2DMultisample(GL_TEXTURE_2D_MULTISAMPLE, samples, GL_RGB, width,
    height, GL_TRUE);
glBindTexture(GL_TEXTURE_2D_MULTISAMPLE, 0);
```

The second argument now sets the number of samples we'd like the texture to have. If the last argument is equal to `GL_TRUE` the image will use identical sample locations and the same number of subsamples for each texel.

To attach a multisampled texture to a framebuffer we use `glFramebufferTexture2D`, but this time with `GL_TEXTURE_2D_MULTISAMPLE` as the texture type:

```
glFramebufferTexture2D(GL_FRAMEBUFFER, GL_COLOR_ATTACHMENT0,
    GL_TEXTURE_2D_MULTISAMPLE, tex, 0);
```

The currently bound framebuffer now has a multisampled color buffer in the form of a texture image.

32.3.2 Multisampled renderbuffer objects

Like textures, creating a multisampled renderbuffer object isn't difficult. It is even quite easy since all we need to change is the call to `glRenderbufferStorage` that is now `glRenderbufferStorageMultisample` when we specify the (currently bound) renderbuffer's memory storage:

```
glRenderbufferStorageMultisample(GL_RENDERBUFFER, 4, GL_DEPTH24_STENCIL8,
    width, height);
```

The one thing that changed here is the extra parameter after the renderbuffer target where we set the amount of samples we'd like to have which is 4 in this particular case.

32.3.3 Render to multisampled framebuffer

Rendering to a multisampled framebuffer object goes automatically. Whenever we draw anything while the framebuffer object is bound, the rasterizer will take care of all the multisample operations. We then end up with a multisampled color buffer and/or depth and stencil buffer. Because a multisampled buffer is a bit special we can't directly use their buffer images for other operations like sampling them in a shader.

A multisampled image contains much more information than a normal image so what we need to do is downscale or [resolve](#) the image. Resolving a multisampled framebuffer is generally done

via `glBlitFramebuffer` that copies a region from one framebuffer to the other while also resolving any multisampled buffers.

`glBlitFramebuffer` transfers a given `source` region defined by 4 screen-space coordinates to a given `target` region also defined by 4 screen-space coordinates. You might remember from the `framebuffers` tutorial that if we bind to `GL_FRAMEBUFFER` we're binding to both the read and draw framebuffer targets. We could also bind to those targets individually by binding the framebuffers to `GL_READ_FRAMEBUFFER` and `GL_DRAW_FRAMEBUFFER` respectively. The `glBlitFramebuffer` function reads from those two targets to determine which is the source and which is the target framebuffer. We could then transfer the multisampled framebuffer output to the actual screen by `blitting` the image to the default framebuffer like so:

```
glBindFramebuffer(GL_READ_FRAMEBUFFER, multisampledFBO);
glBindFramebuffer(GL_DRAW_FRAMEBUFFER, 0);
glBlitFramebuffer(0, 0, width, height, 0, 0, width, height,
    GL_COLOR_BUFFER_BIT, GL_NEAREST);
```

If we then were to render the application we'd get the same output as without a framebuffer: a lime-green cube that is displayed using MSAA and thus shows significantly less jagged edges:

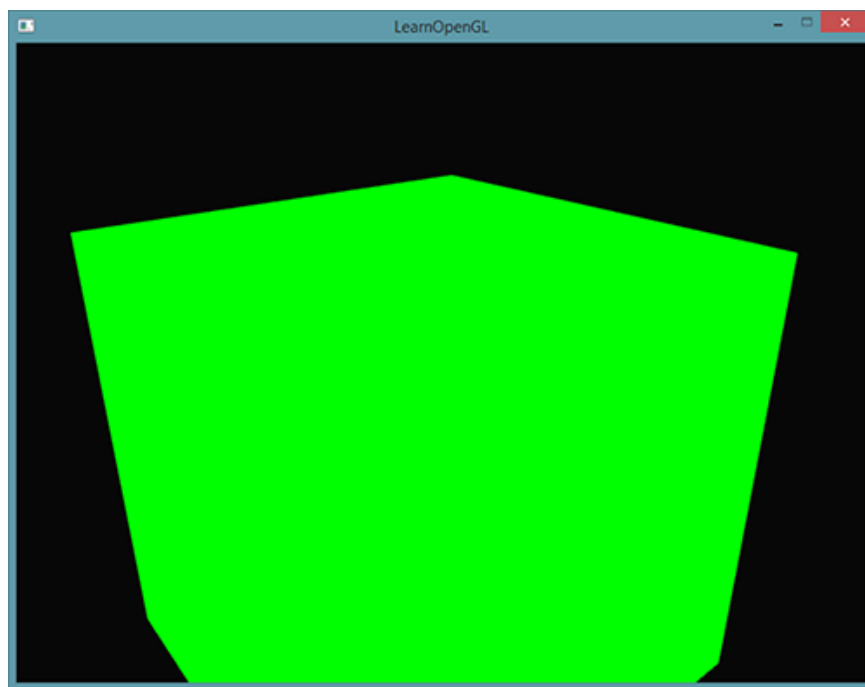

You can find the source code [here](#).

But what if we wanted to use the texture result of a multisampled framebuffer to do stuff like post-processing? We can't directly use the multisampled texture(s) in the fragment shader. What we could do is blit the multisampled buffer(s) to a different FBO with a non-multisampled texture attachment. We then use this ordinary color attachment texture for post-processing, effectively post-processing an image rendered via multisampling. This does mean we have to generate a new FBO that acts solely as an intermediate framebuffer object to resolve the multisampled buffer into a normal 2D texture we can use in the fragment shader. This process looks a bit like this in pseudocode:

```
GLuint msFBO = CreateFBOWithMultiSampledAttachments();
// Then create another FBO with a normal texture color attachment
...
glFramebufferTexture2D(GL_FRAMEBUFFER, GL_COLOR_ATTACHMENT0, GL_TEXTURE_2D,
    screenTexture, 0);
...
while(!glfwWindowShouldClose(window))
{
    ...

    glBindFramebuffer(msFBO);
    ClearFrameBuffer();
    DrawScene();
    // Now resolve multisampled buffer(s) into intermediate FBO
    glBindFramebuffer(GL_READ_FRAMEBUFFER, msFBO);
    glBindFramebuffer(GL_DRAW_FRAMEBUFFER, intermediateFBO);
    glBlitFramebuffer(0, 0, width, height, 0, 0, width, height,
        GL_COLOR_BUFFER_BIT, GL_NEAREST);
    // Now scene is stored as 2D texture image, so use that image for post-
    processing
    glBindFramebuffer(GL_FRAMEBUFFER, 0);
    ClearFramebuffer();
    glBindTexture(GL_TEXTURE_2D, screenTexture);
    DrawPostProcessingQuad();

    ...
}
```

If we'd then implement this into the post-processing code of the [framebuffers](#) tutorial we're able to create all kinds of cool post-processing effects on a texture of a scene with (almost) no jagged edges. With the blur kernel filter applied it'll look something like this:

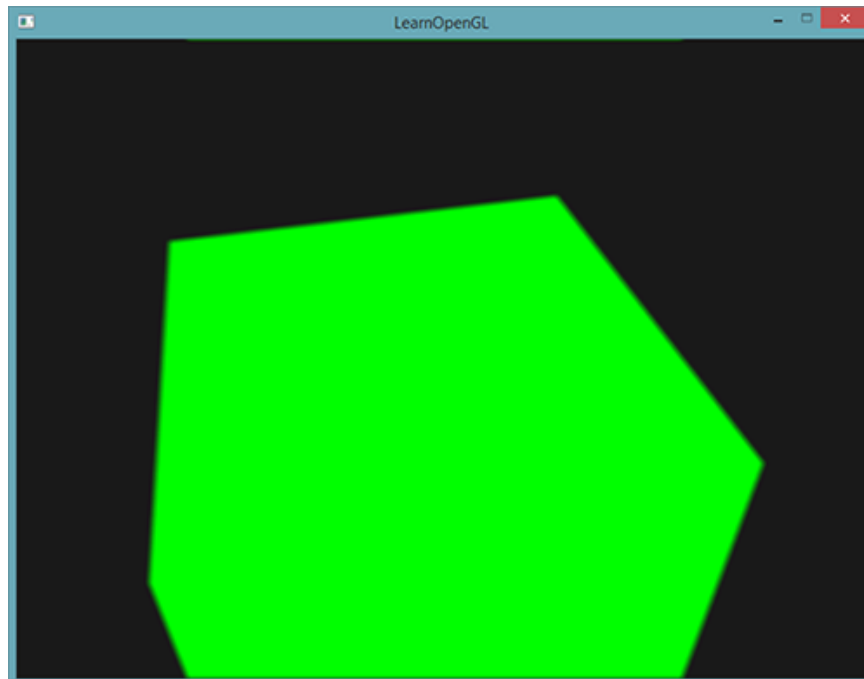

You can find the full source code of the MSAA version of post-processing [here](#).

Because the screen texture is a normal texture again with just a single sample point, some post-processing filters like *edge-detection* will introduce jagged edges again. To accommodate for this you could blur the texture afterwards or create your own anti-aliasing algorithm.

You can see that when we want to combine multisampling with off-screen rendering we'd need to take care of some extra details. All the details are worth the extra effort though since multisampling significantly boosts the visual quality of your scene. Do note that enabling multisampling can noticeably reduce performance of your application the more samples you use. As of this writing, using MSAA with 4 samples is commonly preferred.

32.4 Custom Anti-Aliasing algorithm

It is also possible to directly pass a multisampled texture image to the shaders instead of first resolving them. GLSL then gives us the option to sample the texture images per subsample so we can create our own anti-aliasing algorithms which is commonly done by large graphics applications.

To retrieve the color value per subsample you'd have to define the texture uniform sampler as a `sampler2DMS` instead of the usual `sampler2D`:

```
uniform sampler2DMS screenTextureMS;
```

Using the `texelFetch` function it is then possible to retrieve the color value per sample:

```
vec4 colorSample = texelFetch(screenTextureMS, TexCoords, 3); // 4th  
subsample
```

We won't go into the details of creating custom anti-aliasing techniques, but merely provided some pointers as to how you might implement a feature like this.



Advanced Lighting

33	Advanced Lighting	329
34	Gamma Correction	334
35	Shadow Mapping	342
36	Point Shadows	362
37	Normal Mapping	376
38	Parallax Mapping	392
39	HDR	406
40	Bloom	413
41	Deferred Shading	424
42	SSAO	440

33. Advanced Lighting

In the [lighting](#) tutorials we briefly introduced the Phong lighting model to bring a basic amount of realism into our scenes. The Phong model looks quite nice, but has a few nuances we'll focus on in this tutorial.

33.1 Blinn-Phong

Phong lighting is a great and very efficient approximation of lighting, but its specular reflections break down in certain conditions, specifically when the shininess property is low resulting in a large (rough) specular area. The image below shows what happens when we use a specular shininess exponent of 1.0 on a flat textured plane:

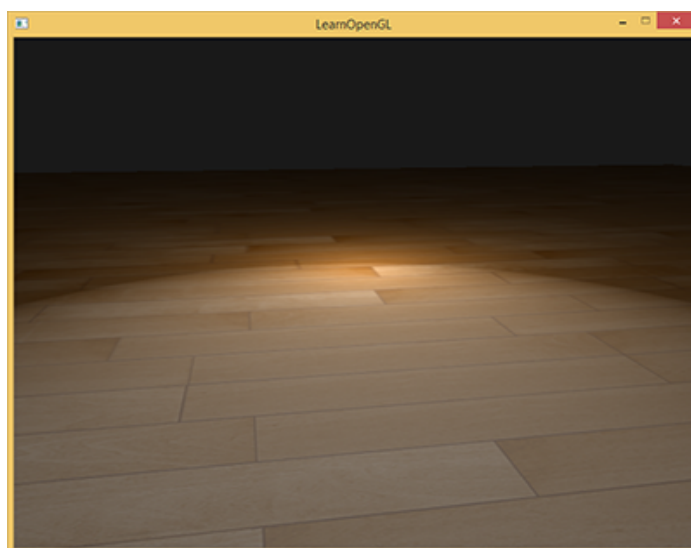

You can see at the edges that the specular area is immediately cut off. The reason this happens

is that the angle between the view vector and the reflection vector is not allowed to go higher than 90 degrees. If the angle is larger than 90 degrees the resulting dot product becomes negative and this results in specular exponents of 0.0 . You're probably thinking this won't be a problem since we shouldn't get any light with angles higher than 90 degrees anyways, right?

Wrong, this only applies to the diffuse component where an angle higher than 90 degrees between the normal and light source means the light source is below the lighted surface and thus the light's diffuse contribution should equal 0.0 . However, with specular lighting we're not measuring the angle between the light source and the normal, but between the view and reflection direction vector. Take a look at the following two images:

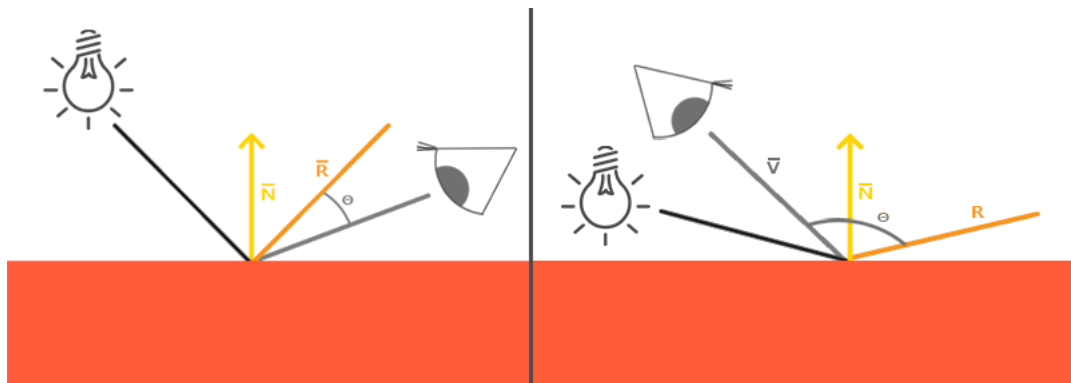

Here the issue should become apparent. The left image shows Phong reflections as familiar with θ being less than 90 degrees. In the right image we can see that the angle θ between the view and reflection direction is larger than 90 degrees and as a result nullifies the specular contribution. This generally isn't a problem since the view direction is far from the reflection direction, but if we use a low specular exponent the specular radius is large enough to have a contribution under these conditions. In that case we're nullifying this contribution at angles larger than 90 degrees (as seen in the first image).

In 1977 the **Blinn-Phong** shading model was introduced by James F. Blinn as an extension to the Phong shading we've used so far. The Blinn-Phong model is largely similar, but approaches the specular model slightly different which as a result overcomes our problem. Instead of relying on a reflection vector we're using a so called **halfway vector** that is a unit vector exactly halfway between the view direction and the light direction. The closer this halfway vector aligns with the surface's normal vector, the higher the specular contribution.

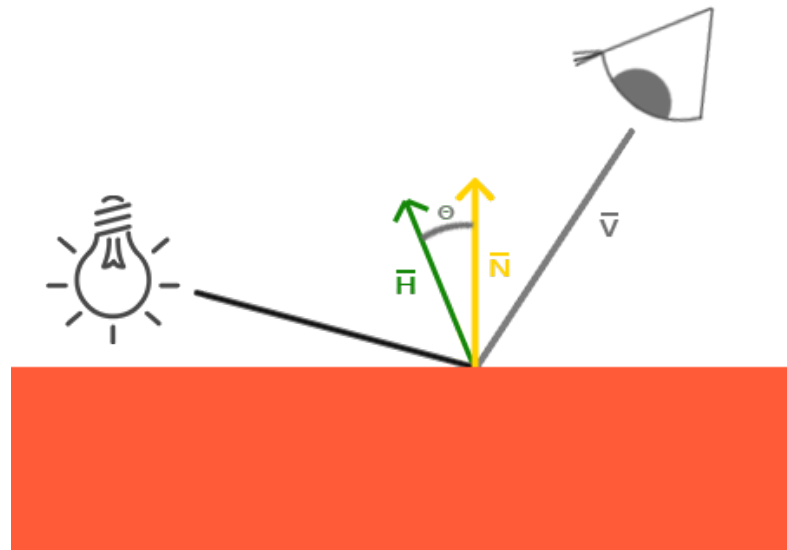

When the view direction is perfectly aligned with the (now imaginary) reflection vector, the halfway vector aligns perfectly with the normal vector. Thus the closer the viewer looks in the original reflection direction, the stronger the specular highlight becomes.

Here you can see that whatever direction the viewer is look from, the angle between the halfway vector and the surface normal never exceeds 90 degrees (unless the light is far below the surface of course). This produces slightly different results compared to Phong reflections, but mostly looks slightly more visually plausible, especially with low specular exponents. The Blinn-Phong shading model is also the exact shading model used in the earlier fixed function pipeline of OpenGL.

Getting the halfway vector is easy, we add the light's direction vector and view vector together and normalize the result:

$$\vec{H} = \frac{\vec{L} + \vec{V}}{\|\vec{L} + \vec{V}\|}$$

This translates to GLSL code as follows:

```
vec3 lightDir = normalize(lightPos - FragPos);
vec3 viewDir = normalize(viewPos - FragPos);
vec3 halfwayDir = normalize(lightDir + viewDir);
```

Then the actual calculation of the specular term basically becomes a clamped dot product between the surface normal and the halfway vector to get the cosine angle between them that we again raise to a specular shininess exponent:

```
float spec = pow(max(dot(normal, halfwayDir), 0.0), shininess);
vec3 specular = lightColor * spec;
```

And there is nothing more to Blinn-Phong than what we just described. The only difference between Blinn-Phong and Phong specular reflection is that we now measure the angle between the normal and the halfway vector compared to the angle between the view direction and the reflection vector.

An interesting side-effect of Blinn-Phong shading is that it is also more efficient compared to Phong shading as we no longer have to compute the computationally more expensive reflection vector.

With the introduction of the halfway vector for calculating the specular highlights we should no longer have the specular cutoff issue of Phong shading. The image below shows the specular area of both methods with a specular exponent of 0.5 :

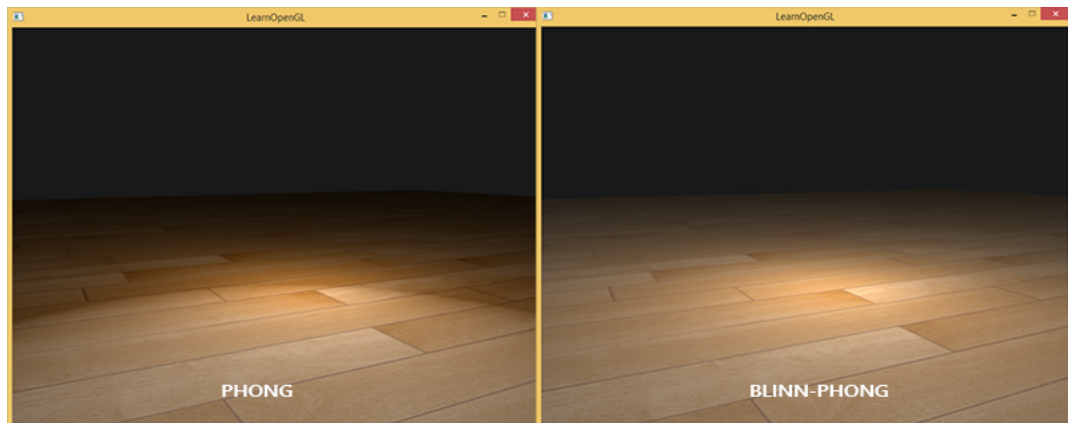

Another subtle difference between Phong and Blinn-Phong shading is that the angle between the halfway vector and the surface normal is often shorter than the angle between the view and reflection vector. As a result, to get similar results to Phong shading the specular shininess exponent has to be set a bit higher. A general rule of thumb is to set it between 2 and 4 times the Phong shininess exponent.

Below is a comparison between both specular reflection models with the Phong exponent set to 8.0 and the Blinn-Phong component set to 32.0 :

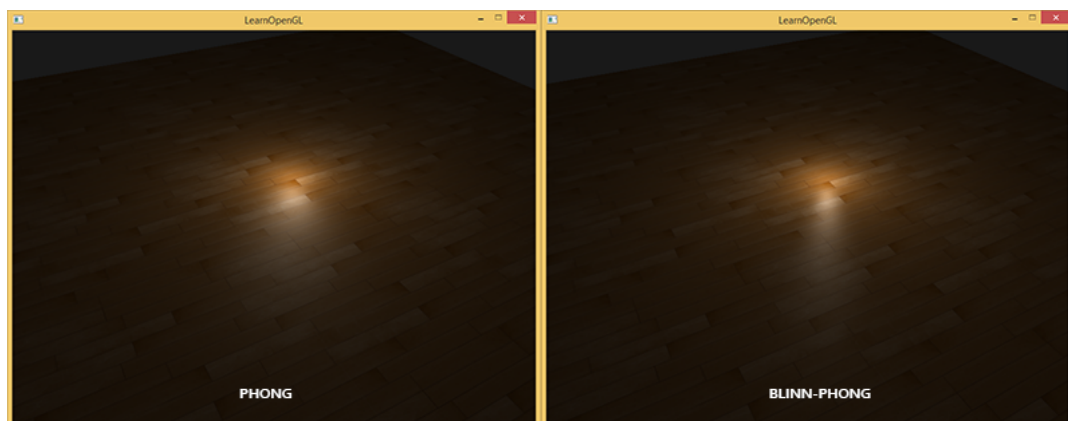

You can see that the Blinn-Phong specular exponent is a bit sharper compared to Phong. It usually requires a bit of tweaking to get similar results as to what you previously had set with Phong shading, but the Blinn-Phong shading gives generally a bit more plausible results compared to default Phong shading.

Here we used a simple fragment shader that switches between regular Phong reflections and Blinn-Phong reflections:

```
void main()
{
    [...]
    float spec = 0.0;
    if (blinn)
    {
        vec3 halfwayDir = normalize(lightDir + viewDir);
        spec = pow(max(dot(normal, halfwayDir), 0.0), 16.0);
    }
    else
    {
        vec3 reflectDir = reflect(-lightDir, normal);
        spec = pow(max(dot(viewDir, reflectDir), 0.0), 8.0);
    }
}
```

You can find the source code for the simple demo [here](#) together with its [vertex](#) and [fragment](#) shader. By pressing the `b` key the demo switches from Phong to Blinn-Phong lighting and vice versa.

34. Gamma Correction

As soon as we computed all the final pixel colors of the scene we will have to display them on a monitor. In the old days of digital imaging most monitors were cathode-ray tube (CRT) monitors. These monitors had the physical property that twice the input voltage did not result in twice the amount of brightness. Doubling the input voltage resulted in a brightness equal to a power relationship of roughly 2.2 also known as the **gamma** of a monitor. This happens to (coincidentally) also closely match how human beings measure brightness as brightness is also displayed with a similar (inverse) power relationship. To better understand what this all means take a look at the following illustration:

Perceived (linear) brightness =	0.0	0.1	0.2	0.3	0.4	0.5	0.6	0.7	0.8	0.9	1.0
Physical (linear) brightness =	0.0	0.1	0.2	0.3	0.4	0.5	0.6	0.7	0.8	0.9	1.0

The top line looks like the correct brightness scale to the human eye, doubling the brightness (from 0.1 to 0.2 for example) does indeed look like it's twice as bright with nice consistent differences. However, when we're talking about the physical brightness of light e.g. amount of photons leaving a light source the bottom scale actually displays the correct brightness. At the bottom scale, doubling the brightness returns the correct physical brightness, but since our eyes perceive brightness differently (more susceptible to changes in dark colors) it looks weird.

Because the human eyes prefer to see brightness colors according to the top scale, monitors (still today) use a power relationship for displaying output colors so that the original physical brightness colors are mapped to the non-linear brightness colors in the top scale; basically because it looks better.

This non-linear mapping of monitors does indeed make the brightness look better in our eyes, but when it comes to rendering graphics there is one issue: all the color and brightness options

we configure in our applications are based on what we perceive from the monitor and thus all the options are actually non-linear brightness/color options. Take a look at the graph below:

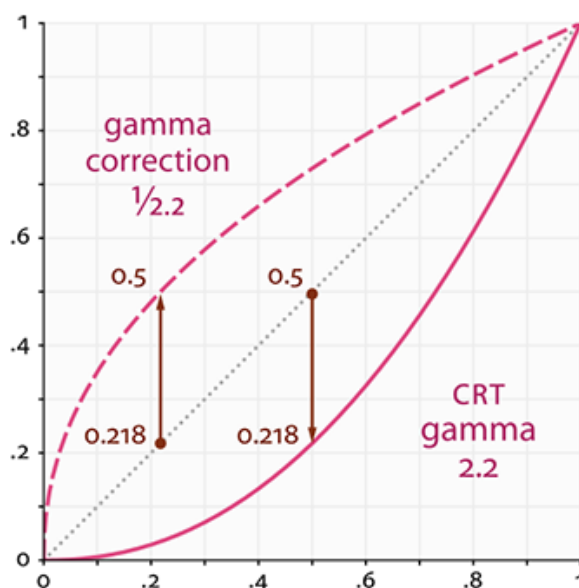

The dotted line represents color/light values in linear space and the solid line represents the color space that monitors display. If we double a color in linear space, its result is indeed double the value. For instance, take a light's color vector $\vec{L} = (0.5, 0.0, 0.0)$ which represents a semi-dark red light. If we would double this light in linear space it would become $(1.0, 0.0, 0.0)$ as you can see in the graph. However, because the colors we defined still have to output to the monitor display, the color gets displayed on the monitor as $(0.218, 0.0, 0.0)$ as you can see from the graph. Here's where the issues starts to rise: once we double the dark-red light in linear space, it actually becomes more than 4.5 times as bright on the monitor!

Up until this tutorial we have assumed we were working in linear space, but we've been actually working in the color space defined by the monitor's output color space so all colors and lighting variables we configured weren't physically correct, but merely looked just right on our monitor. For this reason, we (and artists) generally set lighting values way brighter than they should be (since the monitor darkens them) which as a result makes most linear-space calculations incorrect. Also note that the monitor graph and the linear graph both start and end up at the same position; it is the intermediate colors that get darkened by the display.

Because colors are configured based on the monitor's display all intermediate (lighting) calculations in linear-space are physically incorrect. This becomes more and more obvious as more advanced lighting algorithms are used, as you can see in the image below:



You can see that with gamma correction, the (updated) color values work more nicely together and the darker areas are less dark and thus show more details. Overall, a much better image quality with only small modifications.

Without properly correcting this monitor gamma the lighting just looks wrong and artists will have a hard time getting realistic and good-looking results because incorrectly rendered images cannot simply be corrected by a nice post-processing step. The solution is to apply **gamma correction**.

34.1 Gamma correction

The idea of gamma correction is to apply the inverse of the monitor's gamma to the final output color before displaying to the monitor. Looking back at the gamma curve graph earlier this section we see another *dashed* line that is the inverse of the monitor's gamma curve. We multiply each of the linear output colors by this inverse gamma curve (making them brighter) and as soon as the colors are displayed on the monitor, the monitor's gamma curve is applied and the resulting colors become linear. Basically we make the intermediate colors brighter so that as soon as the monitor darkens them, it balances all out.

Let's give another example. Say we again have the dark-red color (0.5,0.0,0.0). Before displaying this color to the monitor we first apply the gamma correction curve to the color value. Linear colors displayed by a monitor are roughly scaled to a power of 2.2 so the inverse requires scaling the colors by a power of $1/2.2$. The gamma-corrected dark-red color thus becomes $(0.5,0.0,0.0)^{1/2.2} = (0.5,0.0,0.0)^{0.45} = (0.73,0.0,0.0)$. The corrected colors are then fed to the monitor and as a result the color is displayed as $(0.73,0.0,0.0)^{2.2} = (0.5,0.0,0.0)$. You can see that by using gamma-correction, the monitor now finally displays the colors as we linearly set them in the application.

A gamma value of 2.2 is a default gamma value that roughly estimates the average gamma of most displays. The color space as a result of this gamma of 2.2 is called the **sRGB** color space. Each monitor has their own gamma curves, but a gamma value of 2.2 gives good results on most monitors. For this reason, games often allow players to change the game's gamma setting as it varies slightly per monitor.

There are two ways to apply gamma correction to your scenes:

- By using OpenGL's built-in sRGB framebuffer support.
- Or by doing the gamma correction ourselves in the fragment shaders.

The first option is probably the easiest, but also gives you less control. By enabling `GL_FRAMEBUFFER_SRGB` you tell OpenGL that each subsequent drawing commands should first gamma correct colors from the sRGB color space before storing them in color buffer(s). The sRGB is a color space that roughly corresponds to a gamma of 2.2 and a standard for most home devices. After enabling `GL_FRAMEBUFFER_SRGB` OpenGL will automatically perform gamma correction after each fragment shader run to all subsequent framebuffers, including the default framebuffer.

Enabling `GL_FRAMEBUFFER_SRGB` is as simple as calling `glEnable`:

```
glEnable(GL_FRAMEBUFFER_SRGB);
```

From now on your rendered images will be gamma corrected and as this is done by the hardware it is completely free. Something you should keep in mind with this approach (and the other approach) is that gamma correction (also) transforms the colors from linear space to non-linear space so it is very important you only do gamma correction at the last and final step. If you gamma-correct your colors before the final output, all subsequent operations on those colors will operate on incorrect values. For instance, if you use multiple framebuffers you probably want intermediate results passed in between framebuffers to remain in linear-space and only have the last framebuffer apply gamma correction before being sent to the monitor.

The second approach requires a bit more work, but also gives us complete control over the gamma operations. We apply gamma correction at the end of each relevant fragment shader run so the final colors end up gamma corrected before being sent out to the monitor:

```
void main()
{
    // do super fancy lighting
    [...]
    // apply gamma correction
    float gamma = 2.2;
    fragColor.rgb = pow(fragColor.rgb, vec3(1.0/gamma));
}
```

The last line of code effectively raises each individual color component of `fragColor` to $1.0/\text{gamma}$ correcting the output color of this fragment shader run.

An issue with this approach is that in order to be consistent you have to apply gamma correction to each fragment shader that contributes to the final output so if you have a dozen fragment shaders for multiple objects, you have to add the gamma correction code to each of these shaders. An easier solution would be to introduce a post-processing stage in your render loop and apply gamma correction on the post-processed quad as a final step which you'd only have to do once.

These one-liners represent the technical implementation of gamma correction. Not all too impressive, but there are a few extra things you have to consider when doing gamma correction.

34.2 sRGB textures

Because monitors always display colors with gamma applied in sRGB space, whenever you draw, edit or paint a picture on your computer you are picking colors based on what you see on the monitor. This effectively means all the pictures you create or edit are not in linear space, but in sRGB space e.g. doubling a dark-red color on your screen based on your perceived brightness, does not equal double the red component.

As a result, texture artists create all your textures in sRGB space so if we use those textures as they are in our rendering application we have to take this into account. Before we applied gamma correction this was not an issue, because the textures looked good in sRGB space and without gamma correction we also worked in sRGB space so the textures were displayed exactly as they are which was fine. However, now that we're displaying everything in linear space the texture colors will be off as the following image shows:

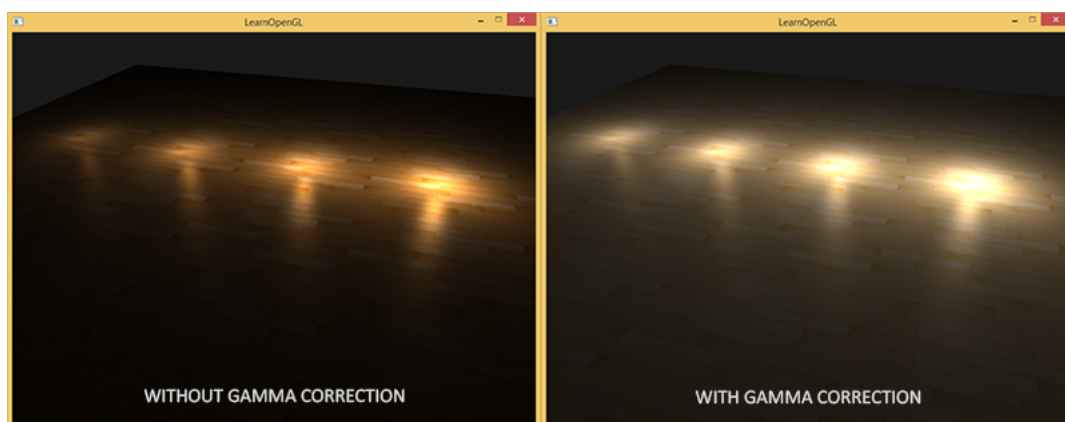

The texture images are way too bright and this happens because they are actually gamma corrected twice! Think about it, when we create an image based on what we see on the monitor, we effectively gamma correct the color values of an image so that it looks right on the monitor. Because we then again gamma correct in the renderer, the images will be way too bright.

To fix this issue we have to make sure texture artists work in linear space. However, since most texture artists don't even know what gamma correction is and it's easier to work in sRGB space this is probably not the preferred solution.

The other solution is to re-correct or transform these sRGB textures back to linear space before doing any calculations on their color values. We can do this as follows:

```
float gamma = 2.2;
vec3 diffuseColor = pow(texture(diffuse, texCoords).rgb, vec3(gamma));
```

To do this for each texture in sRGB space is quite troublesome though. Luckily OpenGL gives us yet another solution to our problems by giving us the `GL_SRGB` and `GL_SRGB_ALPHA` internal texture formats.

If we create a texture in OpenGL with any of these two sRGB texture formats specified, OpenGL will automatically correct the colors to linear-space as soon as we use them, allowing us to properly work in linear space with all color values extracted. We can specify a texture as an sRGB texture as follows:

```
glTexImage2D(GL_TEXTURE_2D, 0, GL_SRGB, width, height, 0, GL_RGB,  
             GL_UNSIGNED_BYTE, image);
```

If you also want to include alpha components in your texture you'll have to specify the texture's internal format as `GL_SRGB_ALPHA`.

You should be careful when specifying your textures in sRGB space as not all textures will actually be in sRGB space. Textures used for coloring objects like diffuse textures are almost always in sRGB space. Textures used for retrieving lighting parameters like [specular maps](#) and [normal maps](#) are almost always in linear space so if you were to configure these as sRGB textures as well, the lighting will break down. Be careful in which textures you specify as sRGB.

With our diffuse textures specified as sRGB textures you get the visual output you'd expect again, but this time everything is gamma corrected only once.

34.3 Attenuation

Another thing that will be different with gamma correction is lighting attenuation. In the real physical world, lighting attenuates closely inversely proportional to the squared distance from a light source. In normal English it simply means that the light strength is reduced over the distance to the light source squared like below:

```
float attenuation = 1.0 / (distance * distance);
```

However, when using this attenuation equation the attenuation effect is always way too strong, giving lights a small radius that didn't look physically right. For that reason other attenuation functions were used like we discussed in the [basic lighting](#) tutorials that give much more control, or the linear equivalent is used:

```
float attenuation = 1.0 / distance;
```

The linear equivalent gives much more plausible results than its quadratic variant without gamma correction, but when we enable gamma correction the linear attenuation looks too weak and the physically correct quadratic attenuation suddenly gives the better results. The image below shows the differences:

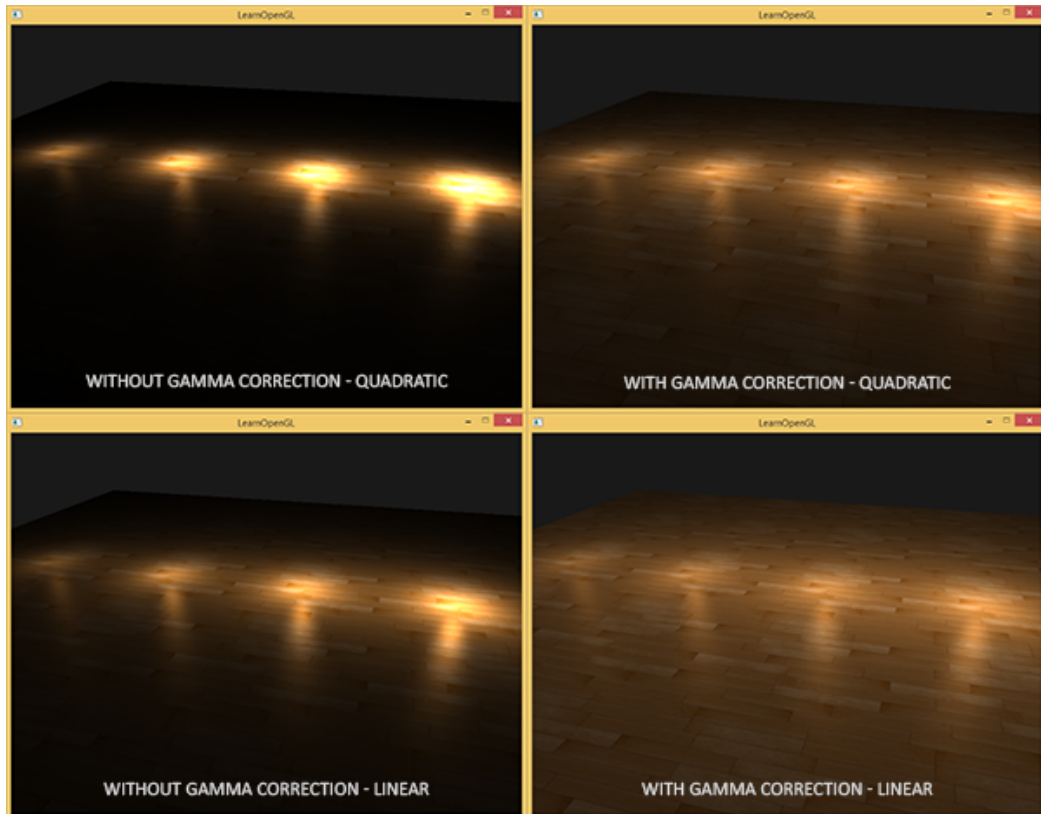

The cause of this difference is that light attenuation functions change brightness, and as we weren't visualizing our scene in linear space, we chose the attenuation functions that looked best on our monitor, but weren't physically correct. Think of the squared attenuation function, if we were to use this function without gamma correction the attenuation function effectively becomes: $(1.0/distance^2)^{2.2}$ when displayed on a monitor. This creates a much larger attenuation effect without gamma correction. This also explains why the linear equivalent makes much more sense without gamma correction as this effectively becomes $(1.0/distance)^{2.2} = 1.0/distance^{2.2}$ which resembles its physical equivalent a lot more.

The more advanced attenuation function we discussed in the [basic lighting](#) is still useful in gamma corrected scenes as it gives much more control over the exact attenuation (but of course requires different parameters in a gamma corrected scene).

I created a simple demo scene of which you can find its source code [here](#) together with its [vertex](#) and [fragment](#) shader. By pressing the spacebar we switch between a gamma corrected and un-corrected scene with both scenes using their texture and attenuation equivalents. It's not the most impressive demo, but it does show how to actually apply all techniques.

To summarize, gamma correction allows you to work/visualize your renders in linear space. Because linear space makes sense in the physical world, most physical equations now actually give good results like real light attenuation. The more advanced your lighting becomes, the easier it is to get good looking (and realistic) results with gamma correction. That is also why it's advised to only really tweak your lighting parameters as soon as you have gamma correction in place.

34.4 Additional resources

- www.cambridgeincolour.com: more about gamma and gamma correction.
- blog.wolfire.com: blog post by David Rosen about the benefit of gamma correction in graphics rendering.
- renderwonk.com: some extra practical considerations.

35. Shadow Mapping

Shadows are a result of the absence of light due to occlusion; when a light source's light rays do not hit an object because it gets occluded by some other object the object is in shadow. Shadows add a great deal of realism to a lighted scene and make it easier for a viewer to observe spatial relationships between objects. They give a greater sense of depth to our scene and objects. For example, take a look at the following image of a scene with and without shadows:

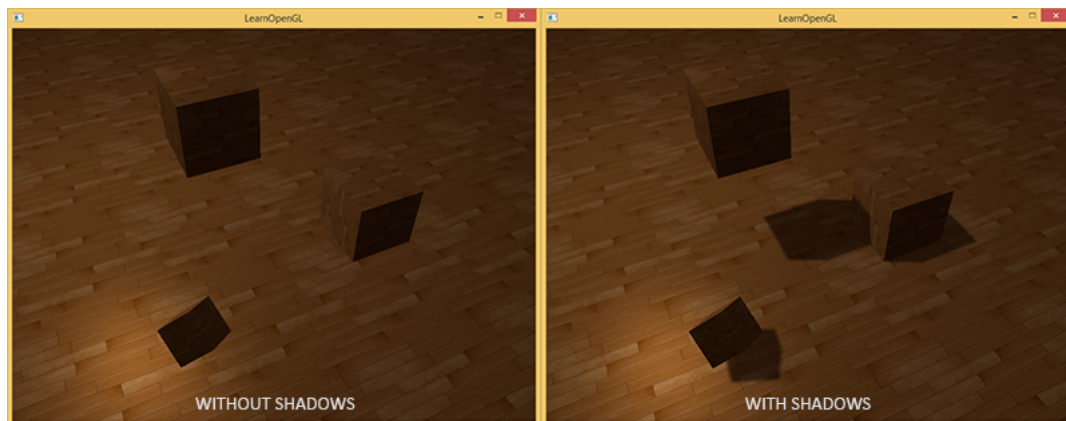

You can see that with shadows it becomes much more obvious how the objects relate to each other. For instance, the fact that one of the cubes is floating above the others is much more noticeable when we have shadows.

Shadows are a bit tricky to implement though, specifically because in current real-time research a perfect shadow algorithm hasn't been developed yet. There are several good shadow approximation techniques, but they all have their little quirks and annoyances which we have to take into account.

One technique used by most videogames that gives decent results and is relatively easy to implement is [shadow mapping](#). Shadow mapping is not too difficult to understand, doesn't

cost too much in performance and is quite easily extended into more advanced algorithms (like [Omnidirectional Shadow Maps](#) and [Cascaded Shadow Maps](#)).

35.1 Shadow mapping

The idea behind shadow mapping is quite simple: we render the scene from the light's point of view and everything we see from the light's perspective is lit and everything we can't see must be in shadow. Imagine a floor section with a large box between itself and a light source. Since the light source will see this box and not the floor section when looking in its direction that specific floor section should be in shadow.

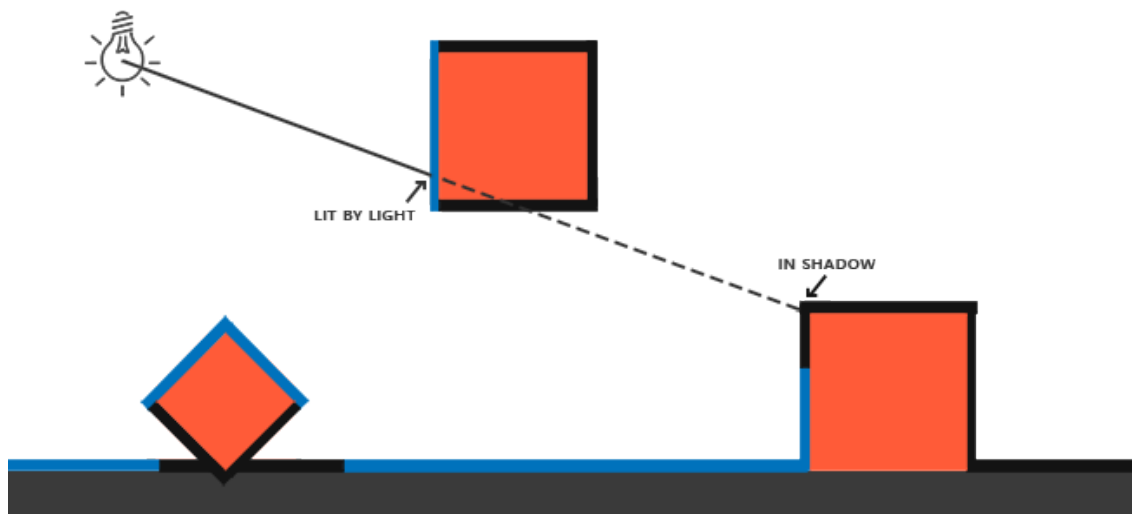

Here all the blue lines represent the fragments that the light source can see. The occluded fragments are shown as black lines: these are rendered as being shadowed. If we were to draw a line or *ray* from the light source to a fragment on the right-most box we can see the ray first hits the floating container before hitting the right-most container. As a result, the floating container's fragment is lit and the right-most container's fragment is not lit and thus in shadow.

We want to get a point on the ray where it first hit an object and compare this *closest point* to other points on this ray. We then do a basic test to see if a test point's ray position is further down the ray than the closest point and if so, the test point must be in shadow. Iterating through possibly thousands of light rays from such a light source is an extremely inefficient approach and doesn't lend itself too well for real-time rendering. We can do something similar, but without casting light rays. Instead, we use something we're quite familiar with: the depth buffer.

You probably remember from the [depth testing](#) tutorial that a value in the depth buffer corresponds to the depth of a fragment clamped to $[0,1]$ from the camera's point of view. What if we were to render the scene from the light's perspective and store the resulting depth values in a texture? This way we can sample the closest depth values as seen from the light's perspective. After all, the depth values show the first fragment visible from the light's perspective. We store all these depth values in a texture that we call a [depth map](#) or [shadow map](#).

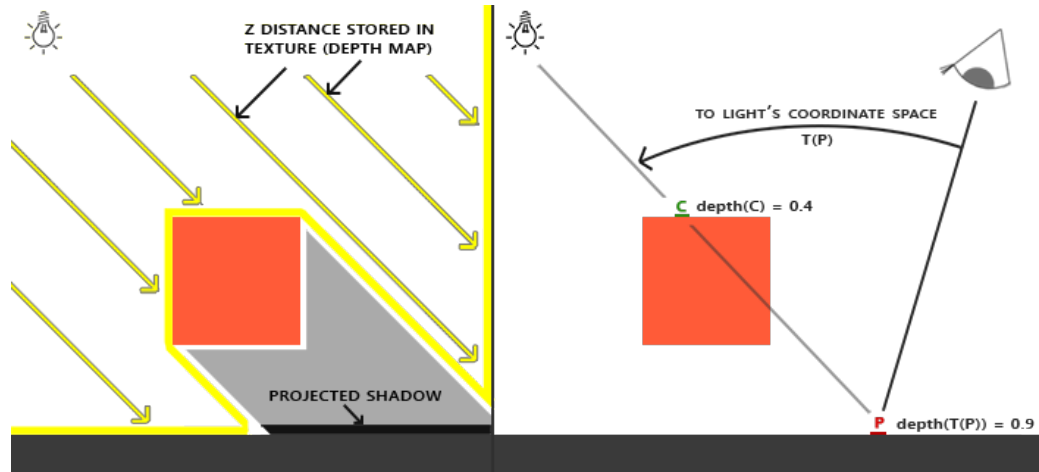

The left image shows a directional light source (all light rays are parallel) casting a shadow on the surface below the cube. Using the depth values stored in the depth map we find the closest point and use that to determine whether fragments are in shadow. We create the depth map by rendering the scene (from the light's perspective) using a view and projection matrix specific to that light source. This projection and view matrix together form a transformation T that transforms any 3D position to the light's visible coordinate space.

A directional light doesn't have a position as it's modelled to be infinitely far away. However, for the sake of shadow mapping we need to render the scene from a light's perspective and thus render the scene from a position somewhere along the lines of the light direction.

In the right image we see the same directional light and the viewer. We render a fragment at point \bar{P} for which we have to determine whether it is in shadow. To do this, we first transform point \bar{P} to the light's coordinate space using T . Since point \bar{P} is now as seen from the light's perspective, its z coordinate corresponds to its depth which in this example is 0.9 . Using point \bar{P} we can also index the depth map to obtain the closest visible depth from the light's perspective which is at point \bar{C} with a sampled depth of 0.4 . Since indexing the depth map returned a depth smaller than the depth at point \bar{P} we can conclude point \bar{P} is occluded and thus in shadow.

Shadow mapping consists of two passes: first we render the depth map and in the second pass we render the scene as normal and use the generated depth map to calculate whether fragments are in shadow. It might sound a bit complicated, but as soon as we walk through the technique step-by-step it'll likely start to make sense.

35.2 The depth map

The first pass requires us to generate a depth map. The depth map is the depth texture as rendered from the light's perspective that we'll be using for calculating shadows. Because we need to store the rendered result of a scene into a texture we're going to need [framebuffers](#) again.

First we'll create a framebuffer object for rendering the depth map:

```
GLuint depthMapFBO;
```

```
glGenFramebuffers(1, &depthMapFBO);
```

Next we create a 2D texture that we'll use as the framebuffer's depth buffer:

```
const GLuint SHADOW_WIDTH = 1024, SHADOW_HEIGHT = 1024;

GLuint depthMap;
glGenTextures(1, &depthMap);
glBindTexture(GL_TEXTURE_2D, depthMap);
glTexImage2D(GL_TEXTURE_2D, 0, GL_DEPTH_COMPONENT,
             SHADOW_WIDTH, SHADOW_HEIGHT, 0, GL_DEPTH_COMPONENT, GL_FLOAT,
             NULL);
glTexParameteri(GL_TEXTURE_2D, GL_TEXTURE_MIN_FILTER, GL_NEAREST);
glTexParameteri(GL_TEXTURE_2D, GL_TEXTURE_MAG_FILTER, GL_NEAREST);
glTexParameteri(GL_TEXTURE_2D, GL_TEXTURE_WRAP_S, GL_REPEAT);
glTexParameteri(GL_TEXTURE_2D, GL_TEXTURE_WRAP_T, GL_REPEAT);
```

Generating the depth map shouldn't look too complicated. Because we only care about depth values we specify the texture's formats as `GL_DEPTH_COMPONENT`. We also give the texture a width and height of 1024: this is the resolution of the depth map.

With the generated depth texture we can attach it as the framebuffer's depth buffer:

```
glBindFramebuffer(GL_FRAMEBUFFER, depthMapFBO);
glFramebufferTexture2D(GL_FRAMEBUFFER, GL_DEPTH_ATTACHMENT, GL_TEXTURE_2D,
                       depthMap, 0);
glDrawBuffer(GL_NONE);
glReadBuffer(GL_NONE);
glBindFramebuffer(GL_FRAMEBUFFER, 0);
```

We only need the depth information when rendering the scene from the light's perspective so there is no need for a color buffer. A framebuffer object however is not complete without a color buffer so we need to explicitly tell OpenGL we're not going to render any color data. We do this by setting both the read and draw buffer to `GL_NONE` with `glDrawBuffer` and `glReadbuffer`.

With a properly configured framebuffer that renders depth values to a texture we can start the first pass: generating the depth map. The complete rendering stage of both passes will look a bit like this:

```
// 1. first render to depth map
glViewport(0, 0, SHADOW_WIDTH, SHADOW_HEIGHT);
glBindFramebuffer(GL_FRAMEBUFFER, depthMapFBO);
glClear(GL_DEPTH_BUFFER_BIT);
ConfigureShaderAndMatrices();
RenderScene();

glBindFramebuffer(GL_FRAMEBUFFER, 0);
// 2. then render scene as normal with shadow mapping (using depth map)
glViewport(0, 0, SCR_WIDTH, SCR_HEIGHT);
glClear(GL_COLOR_BUFFER_BIT | GL_DEPTH_BUFFER_BIT);
ConfigureShaderAndMatrices();
glBindTexture(GL_TEXTURE_2D, depthMap);
RenderScene();
```

This code left out some details, but it'll give you the general idea of shadow mapping. What is important to note here are the calls to `glViewport`. Because shadow maps often have a different

resolution compared to what we originally render the scene in (usually the window resolution) we need to change the viewport parameters to accommodate for the size of the shadow map. If we forget to update the viewport parameters, the resulting depth map will be either incomplete or too small.

35.2.1 Light space transform

An unknown in the previous snippet of code is the `ConfigureShaderAndMatrices` function. In the second pass this is business as usual: make sure proper projection and view matrices are set and the relevant model matrices per object. However, in the first pass we use a different projection and view matrix to render the scene from the light's point of view.

Because we're modelling a directional light source all its light rays are parallel. For this reason we're going to use an orthographic projection matrix for the light source where there is no perspective deform:

```
GLfloat near_plane = 1.0f, far_plane = 7.5f;
glm::mat4 lightProjection = glm::ortho(-10.0f, 10.0f, -10.0f, 10.0f,
    near_plane, far_plane);
```

Here is an example orthographic projection matrix as used in this tutorial's demo scene. Because a projection matrix indirectly determines the range of what is visible e.g. what is not clipped you want to make sure the size of the projection frustum correctly contains the objects you want to be in the depth map. When objects or fragments are not in the depth map they will not produce shadows.

To create a view matrix to transform each object so they're visible from the light's point of view we're going to use the infamous `glm::lookAt` function; this time with the light source's position looking at the scene's center.

```
glm::mat4 lightView = glm::lookAt(glm::vec(-2.0f, 4.0f, -1.0f), glm::vec3
    (0.0f), glm::vec3(1.0));
```

Combining these two gives us a light space transformation matrix that transforms each world-space vector into the space as visible from the light source; exactly what we need to render the depth map.

```
glm::mat4 lightSpaceMatrix = lightProjection * lightView;
```

This `lightSpaceMatrix` is the transformation matrix that we earlier denoted as T . With this `lightSpaceMatrix` we can render the scene as usual as long as we give the shader the light-space equivalents of the projection and view matrices. However, we only care about depth values and not all the expensive fragment calculations in our main shader. To save performance we're going to use a different, but much simpler shader for rendering to the depth map.

35.2.2 Render to depth map

When we render the scene from the light's perspective we'd much rather use a simple shader that only transforms the vertices to light space and not much more. For such a simple shader called `simpleDepthShader` we'll use the following vertex shader:

```
#version 330 core
layout (location = 0) in vec3 position;

uniform mat4 lightSpaceMatrix;
uniform mat4 model;

void main()
{
    gl_Position = lightSpaceMatrix * model * vec4(position, 1.0f);
}
```

This vertex shader takes a per-object model, a vertex and transforms all vertices to light space using `lightSpaceMatrix`.

Since we have no color buffer the resulting fragments do not require any processing, so we can simply use an empty fragment shader:

```
#version 330 core

void main()
{
    // gl_FragDepth = gl_FragCoord.z;
}
```

The empty fragment shader does no processing whatsoever and at the end of its run the depth buffer is updated. We could explicitly set the depth by uncommenting its one line, but this is effectively what happens behind the scene anyways.

Rendering the depth buffer now effectively becomes:

```
simpleDepthShader.Use();
glUniformMatrix4fv(lightSpaceMatrixLocation, 1, GL_FALSE, glm::value_ptr(
    lightSpaceMatrix));

glViewport(0, 0, SHADOW_WIDTH, SHADOW_HEIGHT);
glBindFramebuffer(GL_FRAMEBUFFER, depthMapFBO);
glClear(GL_DEPTH_BUFFER_BIT);
RenderScene(simpleDepthShader);
glBindFramebuffer(GL_FRAMEBUFFER, 0);
```

Here the `RenderScene` function takes a shader program, calls all relevant drawing functions and sets the corresponding model matrices where necessary.

The result is a nicely filled depth buffer holding the closest depth of each visible fragment from the light's perspective. By projecting this texture onto a 2D quad that fills the screen (similar to what we did in the post-processing section at the end of the [framebuffers](#) tutorial) we get something like this:

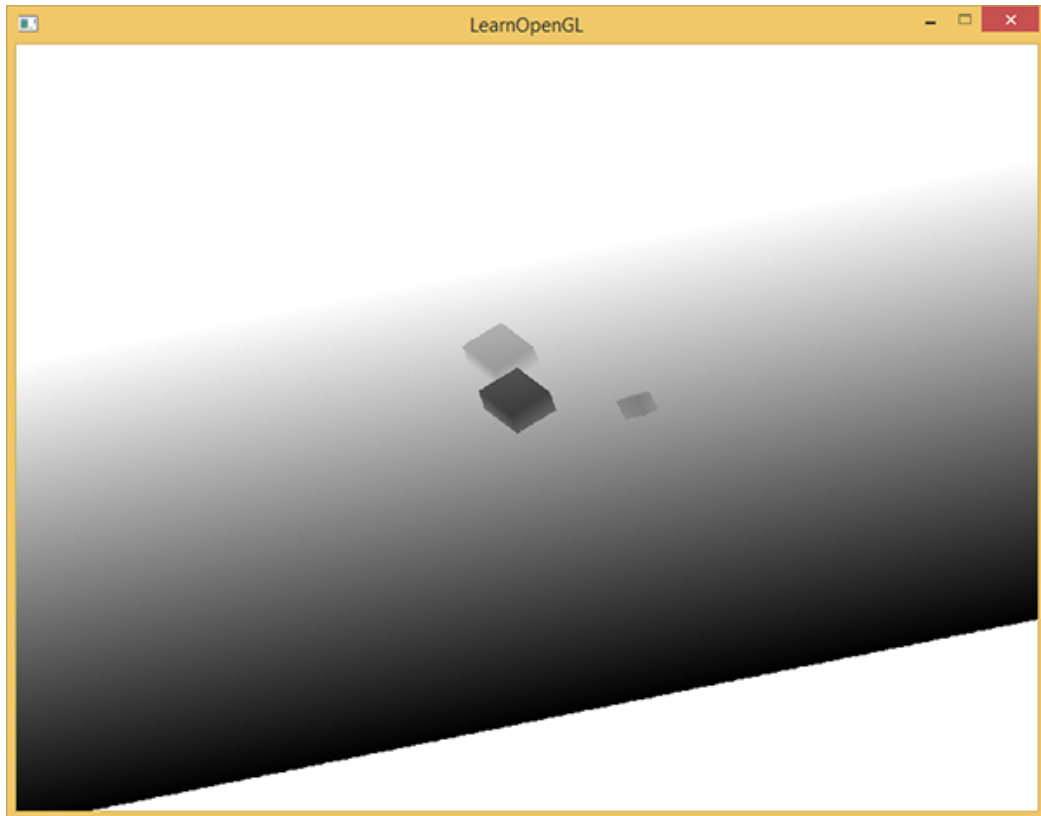

For rendering the depth map onto a quad we used the following fragment shader:

```
#version 330 core
out vec4 color;
in vec2 TexCoords;

uniform sampler2D depthMap;

void main()
{
    float depthValue = texture(depthMap, TexCoords).r;
    color = vec4(vec3(depthValue), 1.0);
}
```

Note that there are some subtle changes when displaying depth using a perspective projection matrix instead of an orthographic projection matrix as depth is non-linear when using perspective projection. At the end of this tutorial we'll discuss some of these subtle differences.

You can find the source code for rendering a scene to a depth map [here](#).

35.3 Rendering shadows

With a properly generated depth map we can start generating the actual shadows. The code to check if a fragment is in shadow is (quite obviously) executed in the fragment shader, but we do the light-space transformation in the vertex shader:

```
#version 330 core
```

```

layout (location = 0) in vec3 position;
layout (location = 1) in vec3 normal;
layout (location = 2) in vec2 texCoords;

out vec2 TexCoords;

out VS_OUT {
    vec3 FragPos;
    vec3 Normal;
    vec2 TexCoords;
    vec4 FragPosLightSpace;
} vs_out;

uniform mat4 projection;
uniform mat4 view;
uniform mat4 model;
uniform mat4 lightSpaceMatrix;

void main()
{
    gl_Position = projection * view * model * vec4(position, 1.0f);
    vs_out.FragPos = vec3(model * vec4(position, 1.0));
    vs_out.Normal = transpose(inverse(mat3(model))) * normal;
    vs_out.TexCoords = texCoords;
    vs_out.FragPosLightSpace = lightSpaceMatrix * vec4(vs_out.FragPos, 1.0)
    ;
}

```

What is new here is the extra output vector `FragPosLightSpace`. We take the same `lightSpaceMatrix` (used to transform vertices to light space in the depth map stage) and transform the world-space vertex position to light space. The vertex shader passes a normally transformed world-space vertex position `vs_out.FragPos` and a light-space transformed `vs_out.FragPosLightSpace` to the fragment shader.

The fragment shader we'll use to render the scene uses the Blinn-Phong lighting model. Within the fragment shader we then calculate a `shadow` value that is either 1.0 when the fragment is in shadow or 0.0 when not in shadow. The resulting `diffuse` and `specular` colors are then multiplied by this shadow component. Because shadows are rarely completely dark due to light scattering we leave the `ambient` color out of the shadow multiplications.

```

#version 330 core
out vec4 FragColor;

in VS_OUT {
    vec3 FragPos;
    vec3 Normal;
    vec2 TexCoords;
    vec4 FragPosLightSpace;
} fs_in;

uniform sampler2D diffuseTexture;
uniform sampler2D shadowMap;

uniform vec3 lightPos;
uniform vec3 viewPos;

float ShadowCalculation(vec4 fragPosLightSpace)
{

```

```

[...]
```

```

}

void main()
{
    vec3 color = texture(diffuseTexture, fs_in.TexCoords).rgb;
    vec3 normal = normalize(fs_in.Normal);
    vec3 lightColor = vec3(1.0);
    // Ambient
    vec3 ambient = 0.15 * color;
    // Diffuse
    vec3 lightDir = normalize(lightPos - fs_in.FragPos);
    float diff = max(dot(lightDir, normal), 0.0);
    vec3 diffuse = diff * lightColor;
    // Specular
    vec3 viewDir = normalize(viewPos - fs_in.FragPos);
    vec3 reflectDir = reflect(-lightDir, normal);
    float spec = 0.0;
    vec3 halfwayDir = normalize(lightDir + viewDir);
    spec = pow(max(dot(normal, halfwayDir), 0.0), 64.0);
    vec3 specular = spec * lightColor;
    // Calculate shadow
    float shadow = ShadowCalculation(fs_in.FragPosLightSpace);
    vec3 lighting = (ambient + (1.0 - shadow) * (diffuse + specular)) *
    color;

    FragColor = vec4(lighting, 1.0f);
}

```

The fragment shader is largely a copy of what we used in the [advanced lighting](#) tutorial, but with an added shadow calculation. We declared a function `ShadowCalculation` that does most of the shadow work. At the end of the fragment shader we multiply the diffuse and specular contributions by the inverse of the `shadow` component e.g. how much the fragment is *not* in shadow. This fragment shader takes as extra input the light-space fragment position and the depth map generated from the first render pass.

The first thing to do to check whether a fragment is in shadow is transform the light-space fragment position in clip-space to normalized device coordinates. When we output a clip-space vertex position to `gl_Position` in the vertex shader, OpenGL automatically does a perspective divide e.g. transform clip-space coordinates in the range $[-w, w]$ to $[-1, 1]$ by dividing the x , y and z component by the vector's w component. As the clip-space `FragPosLightSpace` is not passed to the fragment shader via `gl_Position` we have to do this perspective divide ourselves:

```

float ShadowCalculation(vec4 fragPosLightSpace)
{
    // perform perspective divide
    vec3 projCoords = fragPosLightSpace.xyz / fragPosLightSpace.w;
    [...]
}

```

This returns the fragment's light-space position in the range $[-1, 1]$.

When using an orthographic projection matrix the *w* component of a vertex remains untouched so this step is actually quite meaningless. However, it is necessary when using perspective projection so keeping this line ensures it works with both projection matrices.

Because the depth from the depth map is in the range [0,1] and we also want to use `projCoords` to sample from the depth map so we transform the NDC coordinates to the range [0,1]:

```
projCoords = projCoords * 0.5 + 0.5;
```

With these projected coordinates we can sample the depth map as the resulting [0,1] coordinates from `projCoords` directly correspond to the transformed NDC coordinates from the first render pass. This gives us the closest depth from the light's point of view:

```
float closestDepth = texture(shadowMap, projCoords.xy).r;
```

To get the current depth at the fragment we simply retrieve the projected vector's *z* coordinate which equals the depth of the fragment from the light's perspective.

```
float currentDepth = projCoords.z;
```

The actual comparison is then simply a check whether `currentDepth` is higher than `closestDepth` and if so, the fragment is in shadow.

```
float shadow = currentDepth > closestDepth ? 1.0 : 0.0;
```

The complete `ShadowCalculation` function then becomes:

```
float ShadowCalculation(vec4 fragPosLightSpace)
{
    // perform perspective divide
    vec3 projCoords = fragPosLightSpace.xyz / fragPosLightSpace.w;
    // Transform to [0,1] range
    projCoords = projCoords * 0.5 + 0.5;
    // Get closest depth value from light's perspective (using [0,1] range
    fragPosLight as coords)
    float closestDepth = texture(shadowMap, projCoords.xy).r;
    // Get depth of current fragment from light's perspective
    float currentDepth = projCoords.z;
    // Check whether current frag pos is in shadow
    float shadow = currentDepth > closestDepth ? 1.0 : 0.0;

    return shadow;
}
```

Activating this shader, binding the proper textures and activating the default projection and view matrices in the second render pass should give you a result similar to the image below:

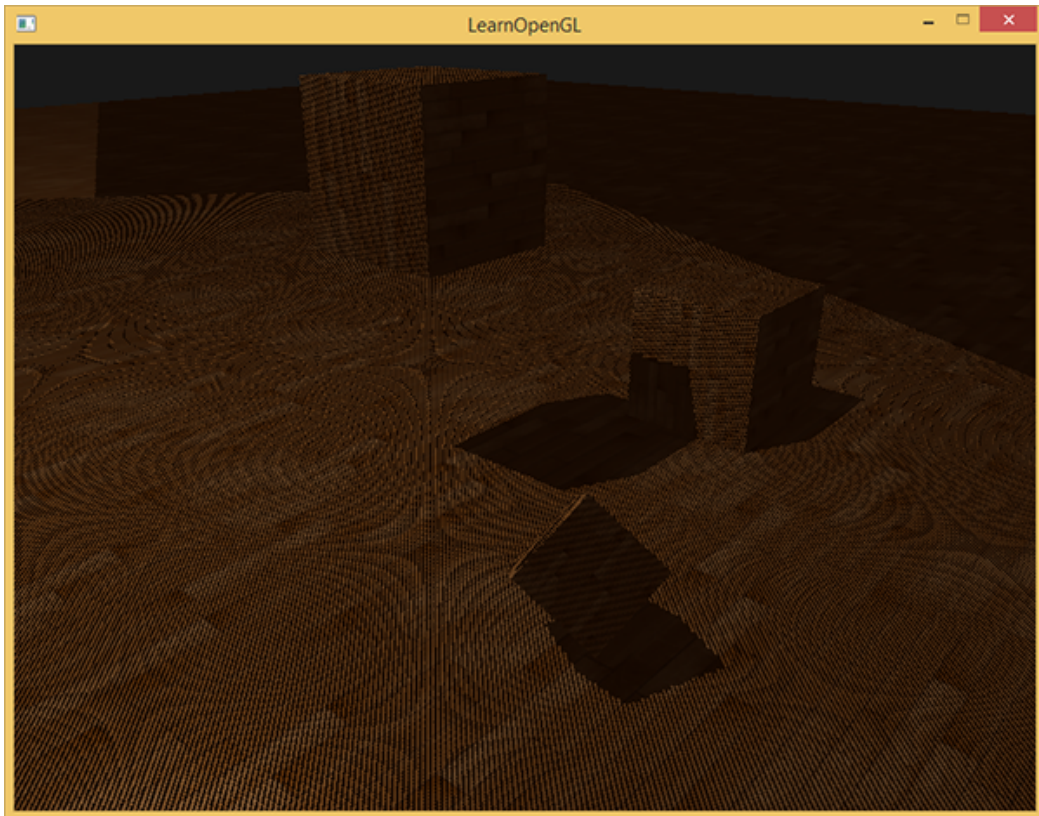

If you did things right you should indeed see (albeit with quite a few artifacts) shadows on the floor and the cubes. You can find the source code of the demo application [here](#).

35.4 Improving shadow maps

We managed to get the basics of shadow mapping working, but as you can see there are still a few artifacts related to shadow mapping that we'd like to fix for better results, which we'll focus on in the next sections.

35.4.1 Shadow acne

It is obvious something is wrong from the previous image. A closer zoom shows us a very obvious Moiré-like pattern:



We can see a large part of the floor quad rendered with obvious black lines in an alternating

fashion. This shadow mapping artifact is called **shadow acne** and can be explained by a simple image:

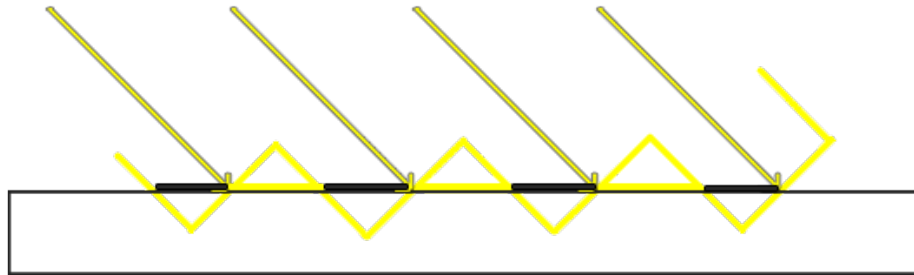

Because the shadow map is limited by resolution, multiple fragments can sample the same value from the depth map when they're relatively far away from the light source. The image shows the floor where each tilted panel represents a single texel of the depth map. As you can see, several fragments sample the same depth sample.

While this is generally okay it becomes an issue when the light source looks at an angle towards the surface as in that case the depth map is also rendered from an angle. Several fragments then access the same tilted depth texel while some are above and some below the floor; we get a shadow discrepancy. Because of this some fragments are deemed in shadow and some are not, giving the striped pattern from the image.

We can solve this issue with a small little hack called a **shadow bias** where we simply offset the depth of the surface (or the shadow map) by a small bias amount such that fragments are not incorrectly considered below the surface.

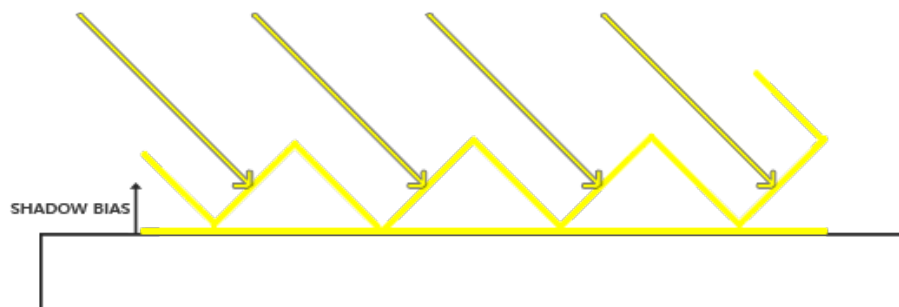

With the bias applied all the samples get a depth smaller than the surface's depth and thus the entire surface is correctly lit without any shadows. We can implement such a bias as follows:

```
float bias = 0.005;
float shadow = currentDepth - bias > closestDepth ? 1.0 : 0.0;
```

A shadow bias of 0.005 solves the issues of our scene by a large extent, but some surfaces that have a steep angle to the light source might still produce shadow acne. A more solid approach would be to change the amount of bias based on the surface angle towards the light: something we can solve with the dot product:

```
float bias = max(0.05 * (1.0 - dot(normal, lightDir)), 0.005);
```

Here we have a maximum bias of 0.05 and a minimum of 0.005 based on the surface's normal and light direction. This way surfaces like the floor that are almost perpendicular to the light source get a small bias, while surfaces like the cube's side-faces get a much larger bias. The following image shows the same scene but now with a shadow bias: much better results.

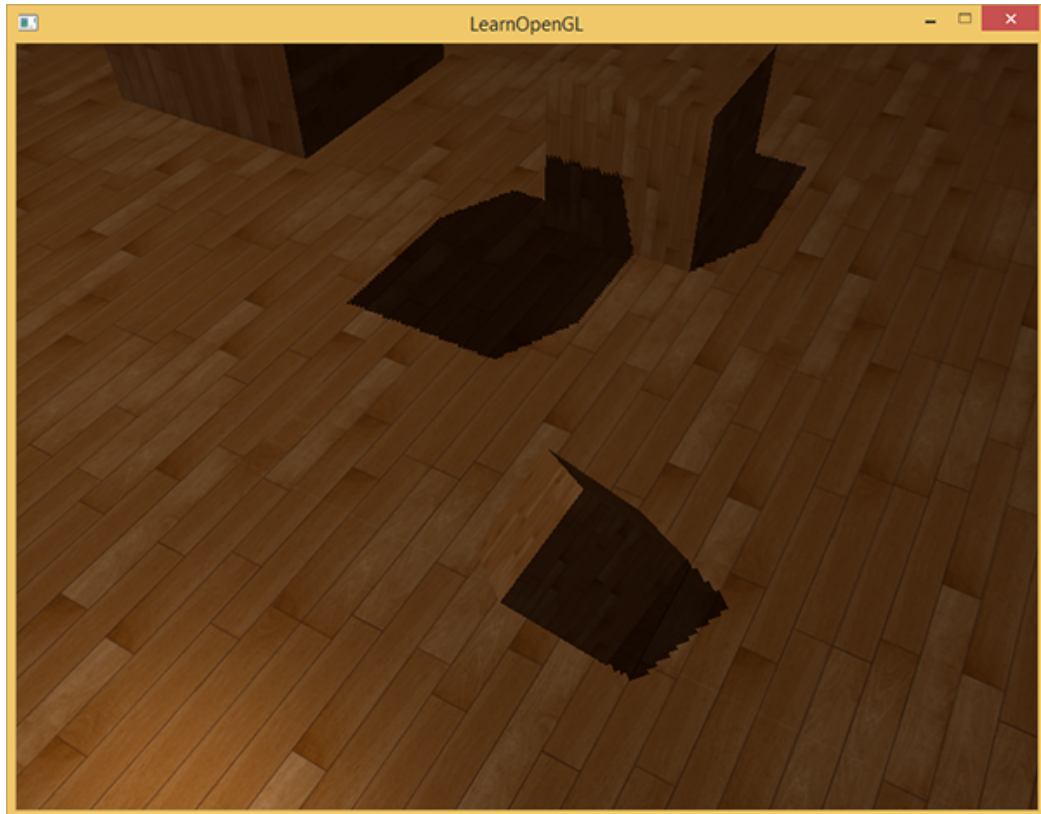

Choosing the correct bias value(s) requires some tweaking as this will be different in each scene, but most of the time it's simply a matter of incrementing the bias until all acne is removed.

35.4.2 Peter panning

A disadvantage of using a shadow bias is that you're applying an offset to the actual depth of objects. As a result the bias might become large enough to see a visible offset of shadows compared to the actual object locations as you can see below (with an exaggerated bias value):



This shadow artifact is called **peter panning** since objects seem to slightly *hover* above the surface. We can use a little trick to solve most of the peter panning issue by using front face culling when rendering the depth map. You might remember from the **face culling** tutorial that OpenGL by default culls back-faces. By telling OpenGL we want to cull front faces we're switching that order around.

Because we only need depth values for the depth map it shouldn't matter for solid objects whether we take the depth of their front faces or their back faces. Using their back face depths doesn't give wrong results as it doesn't matter if we have shadows inside objects; we can't see there anyways.

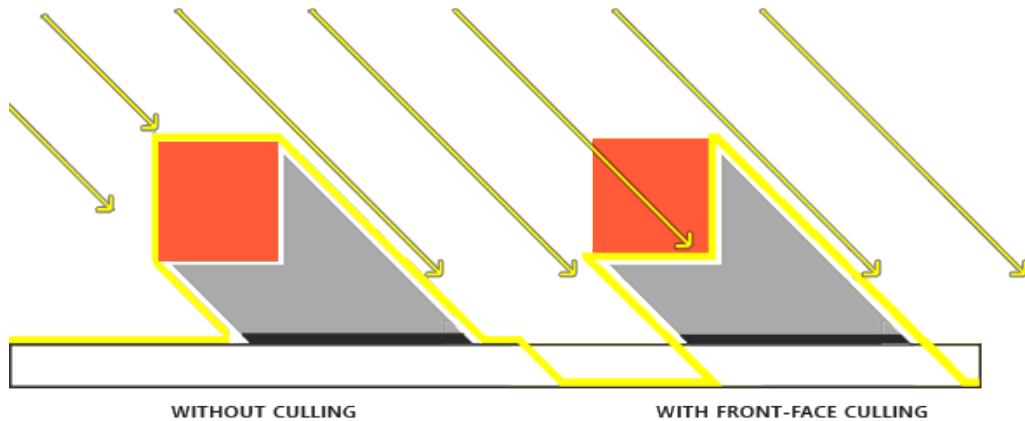

To mostly fix peter panning we cull front faces. Note that you need to enable `GL_CULL_FACE` first.

```
glCullFace(GL_FRONT);
RenderSceneToDepthMap();
glCullFace(GL_BACK); // don't forget to reset original culling face
```

This effectively solves the peter panning issues, but **only for solid** objects that actually have an inside without openings. In our scene for example, this works perfectly fine on the cubes, but won't work on the floor as culling the front face completely removes the floor from the equation. The

floor is a single plane and would thus completely be culled. If one wants to solve peter panning with this trick care has to be taken to only cull the front faces of objects where it makes sense.

Another consideration is that objects that are close to the shadow receiver (like the distant cube) might still give incorrect results. Care should be taken to use front face culling on objects where it makes sense. However, with normal bias values one can generally avoid peter panning.

35.4.3 Over sampling

Another visual discrepancy which you might like or dislike is that some regions outside the light's visible frustum are considered to be in shadow while they're not. This happens because projected coordinates outside the light's frustum are higher than 1.0 and will thus sample the depth texture outside its default range of $[0,1]$. Based on the texture's wrapping method we will get incorrect depth results not based on the real depth values from the light source.

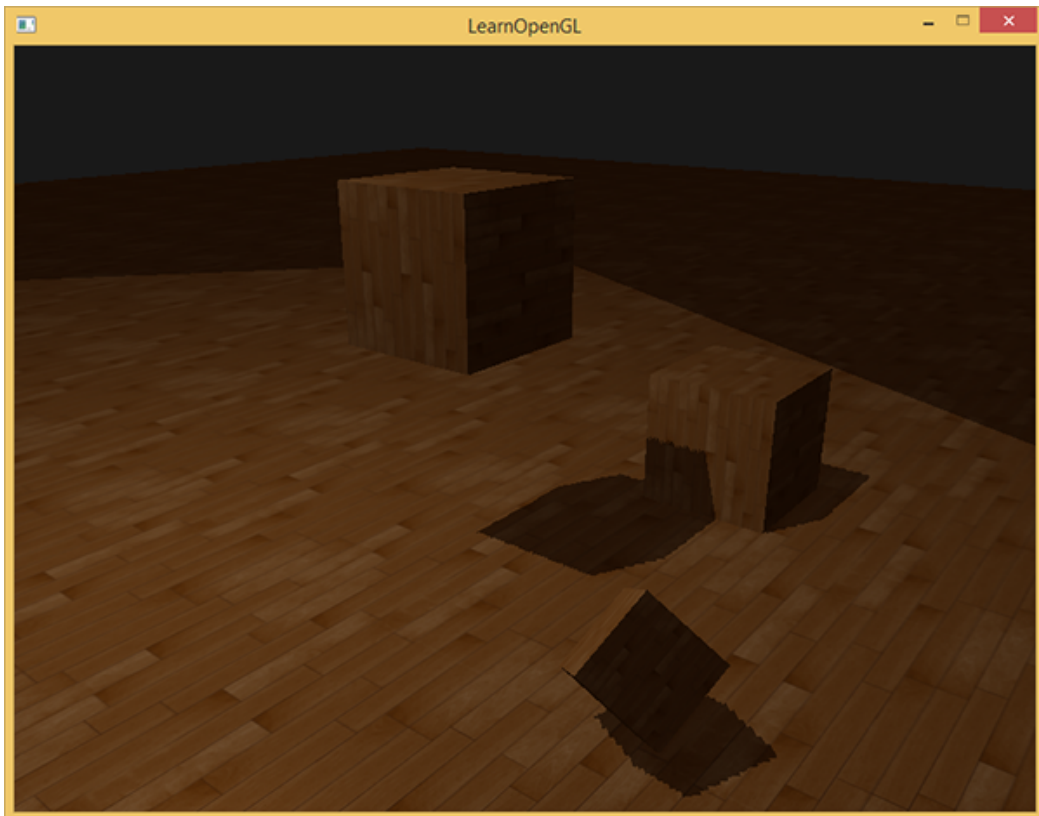

You can see in the image that there is some sort of imaginary region of light and a large part outside this area is in shadow; this area represents the size of the depth map projected onto the floor. The reason this happens is that we earlier set the depth map's wrapping options to `GL_REPEAT`.

What we'd rather have is that all coordinates outside the depth map's range have a depth of 1.0 which as a result means these coordinates will never be in shadow (as no object will have a depth larger than 1.0). We can achieve this by storing a border color and set the depth map's texture wrap options to `GL_CLAMP_TO_BORDER`:

```
glTexParameteri(GL_TEXTURE_2D, GL_TEXTURE_WRAP_S, GL_CLAMP_TO_BORDER);  
glTexParameteri(GL_TEXTURE_2D, GL_TEXTURE_WRAP_T, GL_CLAMP_TO_BORDER);
```

```
GLfloat borderColor[] = { 1.0, 1.0, 1.0, 1.0 };
glTexParameterfv(GL_TEXTURE_2D, GL_TEXTURE_BORDER_COLOR, borderColor);
```

Now whenever we sample outside the depth map's [0,1] coordinate range the `texture` function will always return a depth of 1.0, returning a `shadow` value of 0.0. The result now looks a lot more plausible:

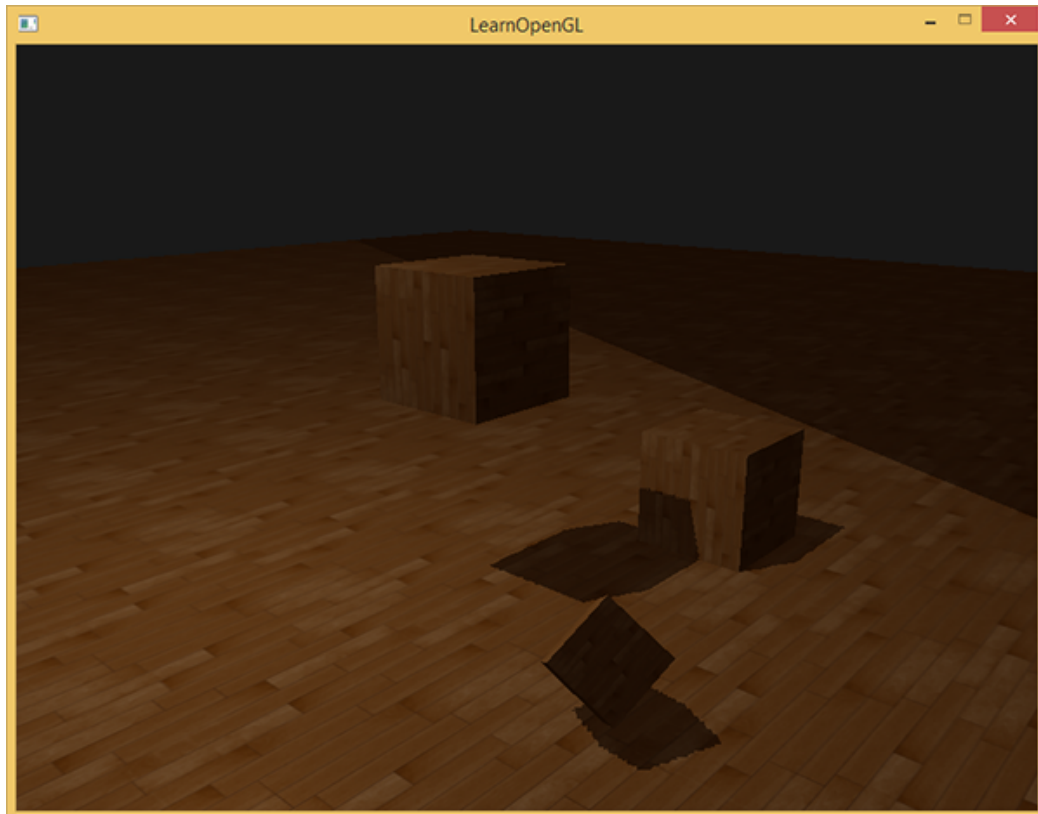

There still seems to be one part still showing a dark region. Those are the coordinates outside the far plane of the light's orthographic frustum. You can see that this dark region always occurs at the far end of the light source's frustum by looking at the shadow directions.

A projected coordinate is further than the light's far plane when its `z` coordinate is larger than 1.0. In that case the `GL_CLAMP_TO_BORDER` wrapping method doesn't work anymore as we compare the coordinate's `z` component with the depth map values; this always returns true for `z` larger than 1.0.

The fix for this is also relatively easy as we simply force the `shadow` value to 0.0 whenever the projected vector's `z` coordinate is larger than 1.0:

```
float ShadowCalculation(vec4 fragPosLightSpace)
{
    [...]
    if(projCoords.z > 1.0)
        shadow = 0.0;

    return shadow;
}
```

Checking the far plane and clamping the depth map to a manually specified border color solves the over-sampling of the depth map and finally gives us the result we are looking for:

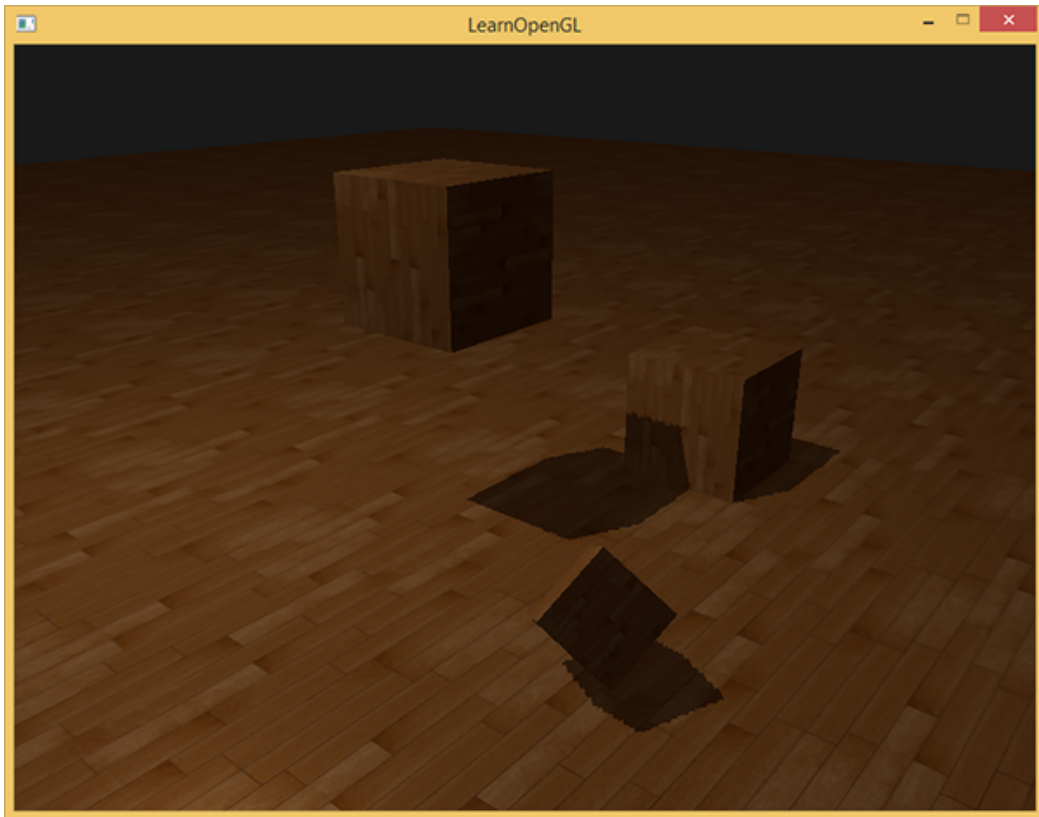

The result of all this does mean that we only have shadows where the projected fragment coordinates sit inside the depth map range so anything outside this range will have no visible shadows. As games usually make sure this only occurs in the distance it is a much more plausible effect than the obvious black regions we had before.

35.5 PCF

The shadows right now are a nice addition to the scenery, but it's still not exactly what we want. If you were to zoom in on the shadows the resolution dependency of shadow mapping quickly becomes apparent.



Because the depth map has a fixed resolution the depth frequently spans more than one fragment

per texel. As a result multiple fragments sample the same depth value from the depth map and come to the same shadow conclusions, which produces these jagged blocky edges.

You can reduce these blocky shadows by increasing the depth map resolution or by trying to fit the light frustum as closely to the scene as possible.

Another (partial) solution to these jagged edges is called PCF or **percentage-closer filtering** which is a term that hosts many different filtering functions that produce *softer* shadows, making them appear less blocky or hard. The idea is to sample more than once from the depth map, each time with slightly different texture coordinates. For each individual sample we check whether it is in shadow or not. All the sub-results are then combined and averaged and we get a nice soft looking shadow.

One simple implementation of PCF is to simply sample the surrounding texels of the depth map and average the results:

```
float shadow = 0.0;
vec2 texelSize = 1.0 / textureSize(shadowMap, 0);
for(int x = -1; x <= 1; ++x)
{
    for(int y = -1; y <= 1; ++y)
    {
        float pcfDepth = texture(shadowMap, projCoords.xy + vec2(x, y) *
texelSize).r;
        shadow += currentDepth - bias > pcfDepth ? 1.0 : 0.0;
    }
}
shadow /= 9.0;
```

Here `textureSize` returns a `vec2` of the width and height of the given sampler texture at mipmap level 0. Divided over 1 this returns the size of a single texel that we use to offset the texture coordinates, making sure each new sample samples a different depth value. Here we sample 9 values around the projected coordinate's `x` and `y` value, test for shadow occlusion and finally average the results by the total number of samples taken.

By using more samples and/or varying the `texelSize` variable you can increase the quality of the soft shadows. Below you can see the shadows with simple PCF applied:

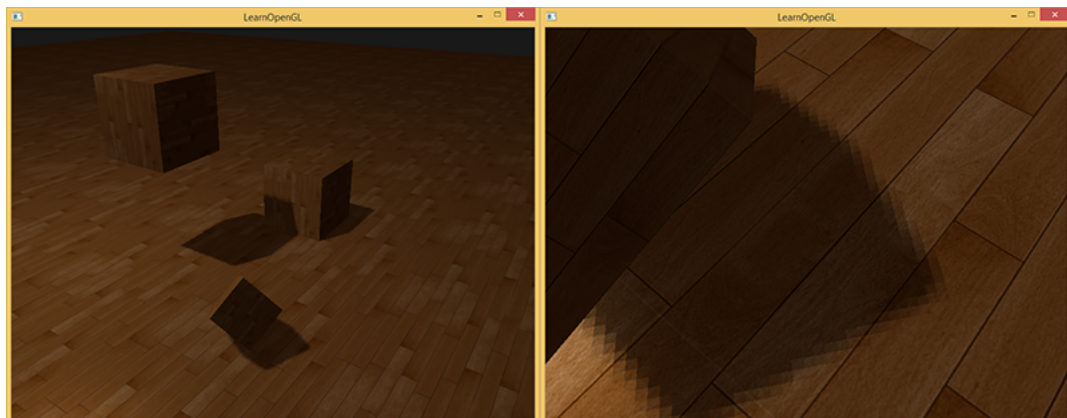

From a distance the shadows look a lot better and less hard. If you zoom in you can still see the

resolution artifacts of shadow mapping, but in general this gives good results for most applications.

You can find the complete source code of the example [here](#) together with the second stage's [vertex](#) and [fragment](#) shader.

There is actually much more to PCF and quite a few techniques to considerably improve the quality of soft shadows, but for the sake of this tutorial's length we'll leave that for a later discussion.

35.6 Orthographic vs projection

There is a difference between rendering the depth map with an orthographic or a projection matrix. An orthographic projection matrix does not deform the scene with perspective so all view/light rays are parallel which makes it a great projection matrix for directional lights. A perspective projection matrix however does deform all vertices based on perspective which gives different results. The following image shows the different shadow regions of both projection methods:

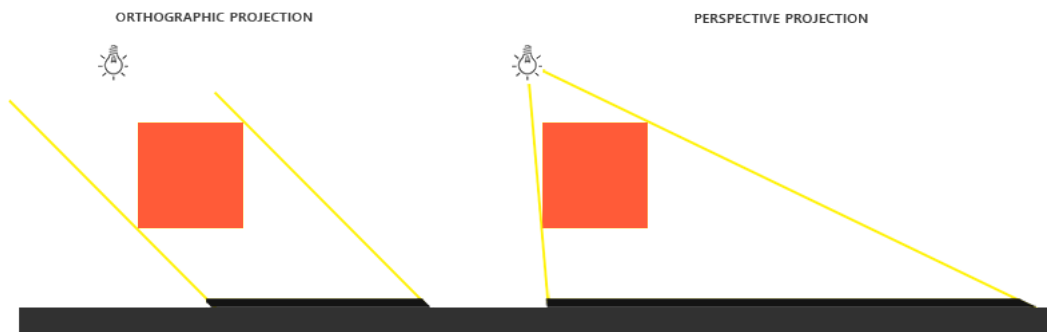

Perspective projections make more sense for light sources that have actual locations unlike directional lights. Perspective projections are thus most often used with spotlights and point lights while orthographic projections are used for directional lights.

Another subtle difference with using a perspective projection matrix is that visualizing the depth buffer will often give an almost completely white result. This happens because with perspective projection the depth is transformed to non-linear depth values with most of its noticeable range close to the near plane. To be able to properly view the depth values as we did with the orthographic projection you first want to transform the non-linear depth values to linear as we discussed in the [depth testing](#) tutorial.

```
#version 330 core
out vec4 color;
in vec2 TexCoords;

uniform sampler2D depthMap;
uniform float near_plane;
uniform float far_plane;

float LinearizeDepth(float depth)
{
    float z = depth * 2.0 - 1.0; // Back to NDC
    return (2.0 * near_plane * far_plane) / (far_plane + near_plane - z * (
        far_plane - near_plane));
}
```



```
}  
  
void main()  
{  
    float depthValue = texture(depthMap, TexCoords).r;  
    color = vec4(vec3(LinearizeDepth(depthValue) / far_plane), 1.0); //  
    perspective  
    // color = vec4(vec3(depthValue), 1.0); // orthographic  
}
```

This shows depth values similar to what we've seen with orthographic projection. Note that this is only useful for debugging; the depth checks remain the same with orthographic or projection matrices as the relative depths do not change.

35.7 Additional resources

- [Tutorial 16 : Shadow mapping](#): similar shadow mapping tutorial by opengl-tutorial.org with a few extra notes.
- [Shadow Mapping - Part 1](#): another shadow mapping tutorial by ogldev.
- [How Shadow Mapping Works](#): a 3-part YouTube tutorial by TheBennyBox on shadow mapping and its implementation.
- [Common Techniques to Improve Shadow Depth Maps](#): a great article by Microsoft listing a large number of techniques to improve the quality of shadow maps.

A futuristic cityscape with a flying vehicle in the foreground. The vehicle is dark with blue lights and is flying towards the left. The city is composed of many tall, thin buildings, some with glowing windows. The sky is a mix of blue and grey, suggesting a hazy or overcast day.

36. Point Shadows

In the last tutorial we learned to create dynamic shadows with shadow mapping. It works great, but it's only suited for directional lights as the shadows are only generated in a single direction of the light source. It is therefore also known as [directional shadow mapping](#) as the depth (or shadow) map is generated from just the direction the light is looking at.

What this tutorial will focus on is the generation of dynamic shadows in all surrounding directions. The technique we're using is perfect for point lights as a real point light would cast shadows in all directions. This technique is known as point (light) shadows or more formerly as [omnidirectional shadow maps](#).

This tutorial builds upon the previous [shadow mapping tutorial](#) so unless you're familiar with traditional shadow mapping it is advised to read the shadow mapping tutorial first.

The algorithm remains mostly the same to directional shadow mapping: we generate a depth map from the light's perspective(s), sample the depth map based on the current fragment position and compare each fragment with the stored depth value to see whether it is in shadow. The main difference between directional shadow mapping and omnidirectional shadow mapping is the depth map used.

The depth map we need requires rendering a scene from all surrounding directions of a point light and as such a normal 2D depth map won't work; what if we were to use a [cubemap](#) instead? Because a cubemap can store environment data with only 6 faces it is possible to render the entire scene to each of the faces of a cubemap and sample these as the point light's surrounding depth values.

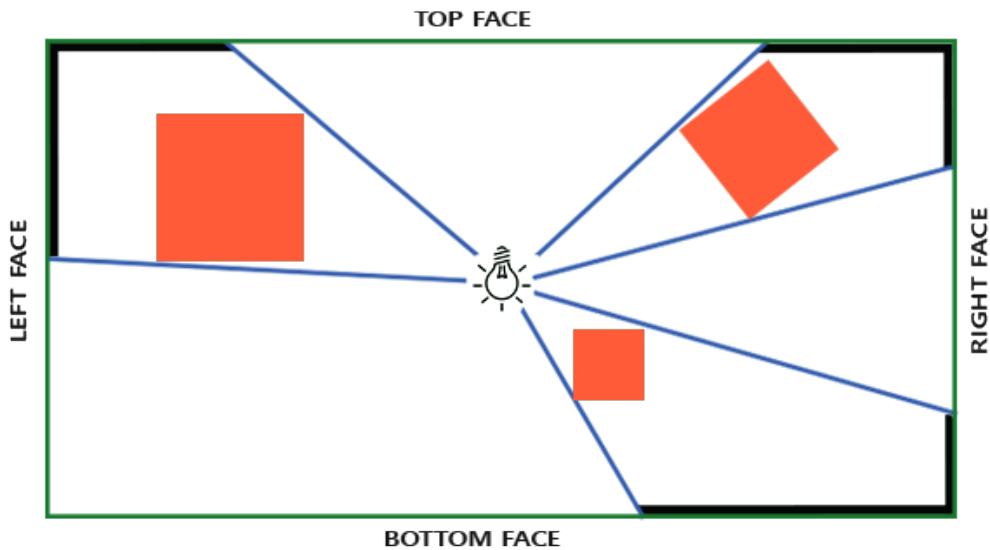

The generated depth cubemap is then passed to the lighting fragment shader that samples the cubemap with a direction vector to obtain the depth (from the light's perspective) at that fragment. Most of the complicated stuff we already discussed in the shadow mapping tutorial. What makes this algorithm slightly more difficult is the depth cubemap generation.

36.1 Generating the depth cubemap

To create a cubemap of a light's surrounding depth values we have to render the scene 6 times: once for each face. One (quite obvious) way to do this is render the scene 6 times with 6 different view matrices, each time attaching a different cubemap face to a framebuffer object. This would look something like this:

```
for(int i = 0; i < 6; i++)
{
    GLuint face = GL_TEXTURE_CUBE_MAP_POSITIVE_X + i;
    glFramebufferTexture2D(GL_FRAMEBUFFER, GL_DEPTH_ATTACHMENT, face,
        depthCubemap, 0);
    BindViewMatrix(lightViewMatrices[i]);
    RenderScene();
}
```

This can be quite expensive though as a lot of render calls are necessary for just a single depth map. In this tutorial we're going to use an alternative (more organized) approach using a little trick in the geometry shader that allows us to build the depth cubemap with just a single render pass.

First, we'll need to create a cubemap:

```
GLuint depthCubemap;
glGenTextures(1, &depthCubemap);
```

And generate each of the single cubemap faces as 2D depth-valued texture images:

```
const GLuint SHADOW_WIDTH = 1024, SHADOW_HEIGHT = 1024;
```

```
glBindTexture(GL_TEXTURE_CUBE_MAP, depthCubemap);
for (GLuint i = 0; i < 6; ++i)
    glTexImage2D(GL_TEXTURE_CUBE_MAP_POSITIVE_X + i, 0,
        GL_DEPTH_COMPONENT,
            SHADOW_WIDTH, SHADOW_HEIGHT, 0, GL_DEPTH_COMPONENT,
        GL_FLOAT, NULL);
```

Also don't forget to set the suitable texture parameters:

```
glTexParameteri(GL_TEXTURE_CUBE_MAP, GL_TEXTURE_MAG_FILTER, GL_NEAREST);
glTexParameteri(GL_TEXTURE_CUBE_MAP, GL_TEXTURE_MIN_FILTER, GL_NEAREST);
glTexParameteri(GL_TEXTURE_CUBE_MAP, GL_TEXTURE_WRAP_S, GL_CLAMP_TO_EDGE);
glTexParameteri(GL_TEXTURE_CUBE_MAP, GL_TEXTURE_WRAP_T, GL_CLAMP_TO_EDGE);
glTexParameteri(GL_TEXTURE_CUBE_MAP, GL_TEXTURE_WRAP_R, GL_CLAMP_TO_EDGE);
```

Normally we'd attach a single face of a cubemap texture to the framebuffer object and render the scene 6 times, each time switching the depth buffer target of the framebuffer to a different cubemap face. Since we're going to use a geometry shader that allows us to render to all faces in a single pass we can directly attach the cubemap as a framebuffer's depth attachment using `glFramebufferTexture`:

```
glBindFramebuffer(GL_FRAMEBUFFER, depthMapFBO);
glFramebufferTexture(GL_FRAMEBUFFER, GL_DEPTH_ATTACHMENT, depthCubemap, 0);
glDrawBuffer(GL_NONE);
glReadBuffer(GL_NONE);
glBindFramebuffer(GL_FRAMEBUFFER, 0);
```

Again, note the call to `glDrawBuffer` and `glReadBuffer`: we only care about depth values when generating a depth cubemap so we have to explicitly tell OpenGL this framebuffer object does not render to a color buffer.

With omnidirectional shadow maps we have two render passes: first we generate the depth map and second, we use the depth map in the normal render pass to create shadows in the scene. With the framebuffer object and the cubemap this process looks a bit like this:

```
// 1. first render to depth cubemap
glViewport(0, 0, SHADOW_WIDTH, SHADOW_HEIGHT);
glBindFramebuffer(GL_FRAMEBUFFER, depthMapFBO);
    glClear(GL_DEPTH_BUFFER_BIT);
    ConfigureShaderAndMatrices();
    RenderScene();
glBindFramebuffer(GL_FRAMEBUFFER, 0);
// 2. then render scene as normal with shadow mapping (using depth cubemap)
glViewport(0, 0, SCR_WIDTH, SCR_HEIGHT);
glClear(GL_COLOR_BUFFER_BIT | GL_DEPTH_BUFFER_BIT);
ConfigureShaderAndMatrices();
glBindTexture(GL_TEXTURE_CUBE_MAP, depthCubemap);
RenderScene();
```

The process is exactly the same as with default shadow mapping, although this time we render to and use a cubemap depth texture compared to a 2D depth texture. Before we actually render the scene from all of the light's viewing directions we first have to calculate the proper transformation matrices.

36.1.1 Light space transform

With the framebuffer and cubemap set we need some way to transform all the scene's geometry to the relevant light spaces in all 6 directions of the light. Similar to the [shadow mapping](#) tutorial we're going to need a light space transformation matrix T , but this time one for each face.

Each light space transformation matrix contains both a projection and a view matrix. For the projection matrix we're going to use a perspective projection matrix; the light source represents a point in space so perspective projection makes most sense. Each light space transformation matrix uses the same projection matrix:

```
GLfloat aspect = (GLfloat)SHADOW_WIDTH/(GLfloat)SHADOW_HEIGHT;
GLfloat near = 1.0f;
GLfloat far = 25.0f;
glm::mat4 shadowProj = glm::perspective(90.0f, aspect, near, far);
```

Important to note here is the field of view parameter of `glm::perspective` that we set to 90 degrees. By setting this to 90 degrees we make sure the viewing field is exactly large enough to properly fill a single face of the cubemap such that all faces align correctly to each other at the edges.

As the projection matrix does not change per direction we can re-use it for each of the 6 transformation matrices. We do need a different view matrix per direction. With `glm::lookAt` we create 6 view directions, each looking at a single direction of the cubemap in the order: right, left, top, bottom, near and far.

```
std::vector<glm::mat4> shadowTransforms;
shadowTransforms.push_back(shadowProj *
    glm::lookAt(lightPos, lightPos + glm::vec3(1.0,0.0,0.0),
    glm::vec3(0.0,-1.0,0.0)));
shadowTransforms.push_back(shadowProj *
    glm::lookAt(lightPos, lightPos + glm::vec3(-1.0,0.0,0.0),
    glm::vec3(0.0,-1.0,0.0)));
shadowTransforms.push_back(shadowProj *
    glm::lookAt(lightPos, lightPos + glm::vec3(0.0,1.0,0.0),
    glm::vec3(0.0,0.0,1.0)));
shadowTransforms.push_back(shadowProj *
    glm::lookAt(lightPos, lightPos + glm::vec3(0.0,-1.0,0.0),
    glm::vec3(0.0,0.0,-1.0)));
shadowTransforms.push_back(shadowProj *
    glm::lookAt(lightPos, lightPos + glm::vec3(0.0,0.0,1.0),
    glm::vec3(0.0,-1.0,0.0)));
shadowTransforms.push_back(shadowProj *
    glm::lookAt(lightPos, lightPos + glm::vec3(0.0,0.0,-1.0),
    glm::vec3(0.0,-1.0,0.0)));
```

Here we create 6 view matrices and multiply them with the projection matrix to get a total of 6 different light space transformation matrices. The `target` parameter of `glm::lookAt` each looks into the direction of a single cubemap face.

These transformation matrices are sent to the shaders that render the depth into the cubemap.

36.1.2 Depth shaders

To render depth values to a depth cubemap we're going to need a total of three shaders: a vertex and fragment shader and a [geometry shader](#) in between.

The geometry shader will be the shader responsible for transforming all world-space vertices to 6 different light spaces. Therefore the vertex shader simply transforms vertices to world-space and directs them to the geometry shader:

```
#version 330 core
layout (location = 0) in vec3 position;

uniform mat4 model;

void main()
{
    gl_Position = model * vec4(position, 1.0);
}
```

The geometry shader then takes as input 3 triangle vertices and a uniform array of light space transformation matrices. The geometry shader is then responsible for transforming the vertices to the light spaces; this is also where it gets interesting.

The geometry shader has a built-in variable called [gl_Layer](#) that specifies which cubemap face to emit a primitive to. When left alone the geometry shader just sends its primitives further down the pipeline as usual, but when we update this variable we can control to which cubemap face we render to for each primitive. This of course only works when we have a cubemap texture attached to the active framebuffer.

```
#version 330 core
layout (triangles) in;
layout (triangle_strip, max_vertices=18) out;

uniform mat4 shadowMatrices[6];

out vec4 FragPos; // FragPos from GS (output per emitvertex)

void main()
{
    for(int face = 0; face < 6; ++face)
    {
        gl_Layer = face; // built-in variable that specifies to which face
        we render.
        for(int i = 0; i < 3; ++i) // for each triangle's vertices
        {
            FragPos = gl_in[i].gl_Position;
            gl_Position = shadowMatrices[face] * FragPos;
            EmitVertex();
        }
        EndPrimitive();
    }
}
```

This geometry shader should be relatively straightforward. We take as input a triangle and output a total of 6 triangles (6 * 3 vertices each equals 18 vertices). In the `main` function we iterate over 6 cubemap faces where we specify each face as the output face by storing the face integer

into `gl_Layer`. Then we generate each triangle by transforming each world-space vertex to the relevant light space by multiplying `FragPos` with the face's light-space transformation matrix. Note that we also sent the resulting `FragPos` variable to the fragment shader that we'll need to calculate a depth value.

In the last tutorial we used an empty fragment shader and let OpenGL figure out the depth values of the depth map. This time we're going to calculate our own (linear) depth as the linear distance between each fragment position and the light source's position. Calculating our own depth values makes the later shadow calculations a bit more intuitive.

```
#version 330 core
in vec4 FragPos;

uniform vec3 lightPos;
uniform float far_plane;

void main()
{
    // get distance between fragment and light source
    float lightDistance = length(FragPos.xyz - lightPos);

    // map to [0;1] range by dividing by far_plane
    lightDistance = lightDistance / far_plane;

    // Write this as modified depth
    gl_FragDepth = gl_FragCoord.z;
}
```

The fragment shader takes as input the `FragPos` from the geometry shader, the light's position vector and the frustum's far plane value. Here we take the distance between the fragment and the light source, map it to the `[0,1]` range and write it as the fragment's depth value.

Rendering the scene with these shaders and the cubemap-attached framebuffer object active should give you a completely filled depth cubemap for the second pass's shadow calculations.

36.2 Omnidirectional shadow maps

With everything set up it is time to render the actual omnidirectional shadows. The procedure is similar to the directional shadow mapping tutorial although this time we bind a cubemap texture instead of a 2D texture as the depth map and also pass the light projection's far plane variable to the shaders.

```
glViewport(0, 0, SCR_WIDTH, SCR_HEIGHT);
glClear(GL_COLOR_BUFFER_BIT | GL_DEPTH_BUFFER_BIT);
shader.Use();
// ... send uniforms to shader (including light's far_plane value)
glActiveTexture(GL_TEXTURE0);
glBindTexture(GL_TEXTURE_CUBE_MAP, depthCubemap);
// ... bind other textures
RenderScene();
```

Here the `renderScene` function renders some cubes in a large cube room scattered around a light source at the center of the scene.

The vertex shader and fragment shader are largely similar to the original shadow mapping shaders: the differences being that the fragment shader no longer requires a fragment position in light space as we can now sample the depth values using a direction vector.

Because of this the vertex shader no longer needs to transform its position vectors to light space so we can exclude the `FragPosLightSpace` variable:

```
#version 330 core
layout (location = 0) in vec3 position;
layout (location = 1) in vec3 normal;
layout (location = 2) in vec2 texCoords;

out vec2 TexCoords;

out VS_OUT {
    vec3 FragPos;
    vec3 Normal;
    vec2 TexCoords;
} vs_out;

uniform mat4 projection;
uniform mat4 view;
uniform mat4 model;

void main()
{
    gl_Position = projection * view * model * vec4(position, 1.0f);
    vs_out.FragPos = vec3(model * vec4(position, 1.0));
    vs_out.Normal = transpose(inverse(mat3(model))) * normal;
    vs_out.TexCoords = texCoords;
}
```

The fragment shader's Blinn-Phong lighting code is exactly the same as we had before with a shadow multiplication at the end:

```
#version 330 core
out vec4 FragColor;

in VS_OUT {
    vec3 FragPos;
    vec3 Normal;
    vec2 TexCoords;
} fs_in;

uniform sampler2D diffuseTexture;
uniform samplerCube depthMap;

uniform vec3 lightPos;
uniform vec3 viewPos;

uniform float far_plane;

float ShadowCalculation(vec3 fragPos)
{
    [...]
}

void main()
```

```

{
    vec3 color = texture(diffuseTexture, fs_in.TexCoords).rgb;
    vec3 normal = normalize(fs_in.Normal);
    vec3 lightColor = vec3(0.3);
    // Ambient
    vec3 ambient = 0.3 * color;
    // Diffuse
    vec3 lightDir = normalize(lightPos - fs_in.FragPos);
    float diff = max(dot(lightDir, normal), 0.0);
    vec3 diffuse = diff * lightColor;
    // Specular
    vec3 viewDir = normalize(viewPos - fs_in.FragPos);
    vec3 reflectDir = reflect(-lightDir, normal);
    float spec = 0.0;
    vec3 halfwayDir = normalize(lightDir + viewDir);
    spec = pow(max(dot(normal, halfwayDir), 0.0), 64.0);
    vec3 specular = spec * lightColor;
    // Calculate shadow
    float shadow = ShadowCalculation(fs_in.FragPos);
    vec3 lighting = (ambient + (1.0 - shadow) * (diffuse + specular)) *
    color;

    FragColor = vec4(lighting, 1.0f);
}

```

There are a few subtle differences: the lighting code is the same, but we now have a `samplerCube` uniform and the `ShadowCalculation` function takes the fragment's position as its parameter instead of the fragment position in light space. We now also include the light frustum's `far_plane` value that we'll later need. At the end of the fragment shader run we calculate the shadow component which is 1.0 when the fragment is in shadow or 0.0 when it's not. We use the calculated shadow component to influence the lighting's diffuse and specular components.

What is largely different is the content of the `ShadowCalculation` function that now samples depth values from a cubemap instead of a 2D texture. Let's discuss its content step by step.

The first thing we have to do is retrieve the depth of the cubemap. As you might remember from the cubemap section of this tutorial is that we stored the depth as the linear distance between a fragment and the light position; we're taking a similar approach here:

```

float ShadowCalculation(vec3 fragPos)
{
    vec3 fragToLight = fragPos - lightPos;
    float closestDepth = texture(depthMap, fragToLight).r;
}

```

Here we take the difference vector between the fragment's position and the light's position and use that vector as a direction vector to sample the cubemap. The direction vector doesn't need to be a unit vector to sample from a cubemap so there's no need to normalize it. The resulting `closestDepth` is the normalized depth value between the light source and its closest visible fragment.

The `closestDepth` value is currently in the range [0,1] so we first transform it back to [0, `far_plane`] by multiplying it with `far_plane`.

```
closestDepth *= far_plane;
```

Next we retrieve the depth value between the current fragment and the light source which we can easily obtain by taking the length of `fragToLight` due to how we calculated depth values in the cubemap:

```
float currentDepth = length(fragToLight);
```

This returns a depth value in the same (or larger) range as `closestDepth`.

Now we can compare both depth values to see which is closer than the other and determine whether the current fragment is in shadow. We also include a shadow bias so we don't get shadow acne as discussed in the [previous](#) tutorial.

```
float bias = 0.05;
float shadow = currentDepth - bias > closestDepth ? 1.0 : 0.0;
```

The complete `ShadowCalculation` then becomes:

```
float ShadowCalculation(vec3 fragPos)
{
    // Get vector between fragment position and light position
    vec3 fragToLight = fragPos - lightPos;
    // Use the light to fragment vector to sample from the depth map
    float closestDepth = texture(depthMap, fragToLight).r;
    // It is currently in linear range between [0,1]. Re-transform back to
    // original value
    closestDepth *= far_plane;
    // Now get current linear depth as the length between the fragment and
    // light position
    float currentDepth = length(fragToLight);
    // Now test for shadows
    float bias = 0.05;
    float shadow = currentDepth - bias > closestDepth ? 1.0 : 0.0;

    return shadow;
}
```

With these shaders we already get pretty good shadows and this time in all surrounding directions from a point light. With a point light positioned at the center of a simple scene it'll look a bit like this:

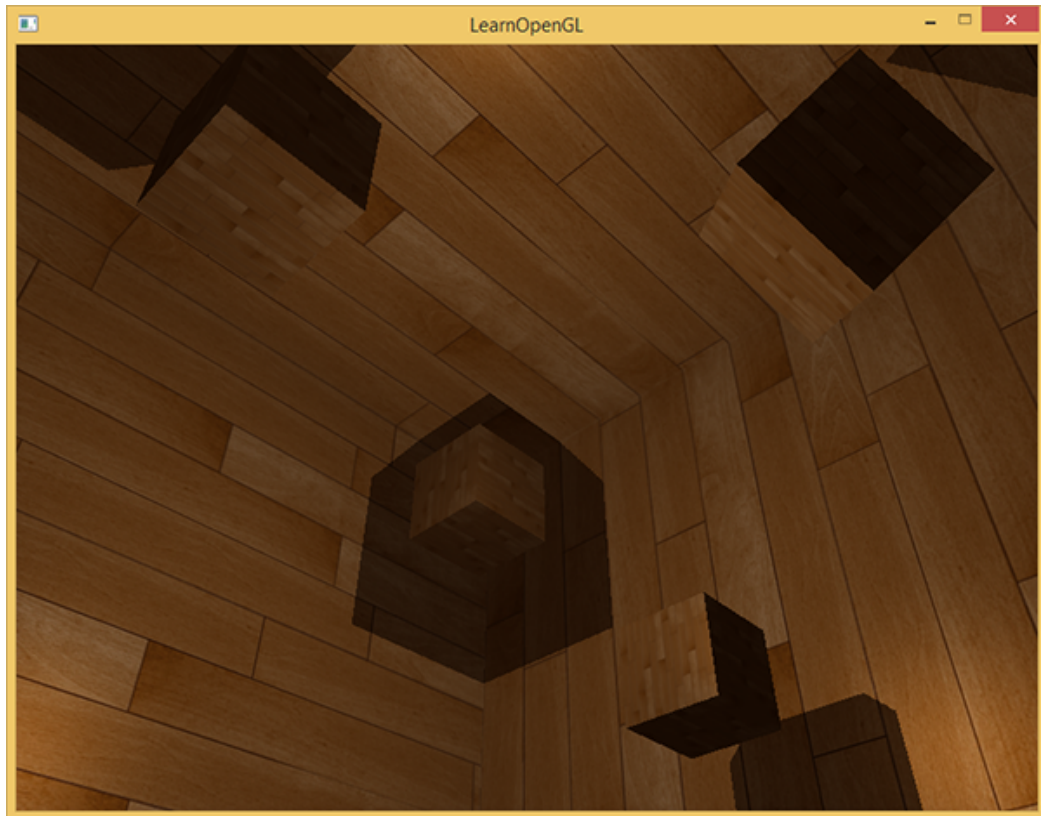

You can find the source code of this demo [here](#) together with its [vertex](#) and [fragment](#) shader.

36.2.1 Visualizing cubemap depth buffer

If you're somewhat like me you probably didn't get this right on the first try so it makes sense to do some debugging with one of the obvious checks being validating whether the depth map was built correctly. Because we don't have a 2D depth map texture anymore visualizing the depth map becomes a bit less obvious.

A simple trick to visualize the depth buffer is to take the normalized (in the range $[0,1]$) `closestDepth` variable in the `ShadowCalculation` function and display that variable as:

```
FragColor = vec4(vec3(closestDepth / far_plane), 1.0);
```

The result is a grayed out scene where each color represents the linear depth values of the scene:

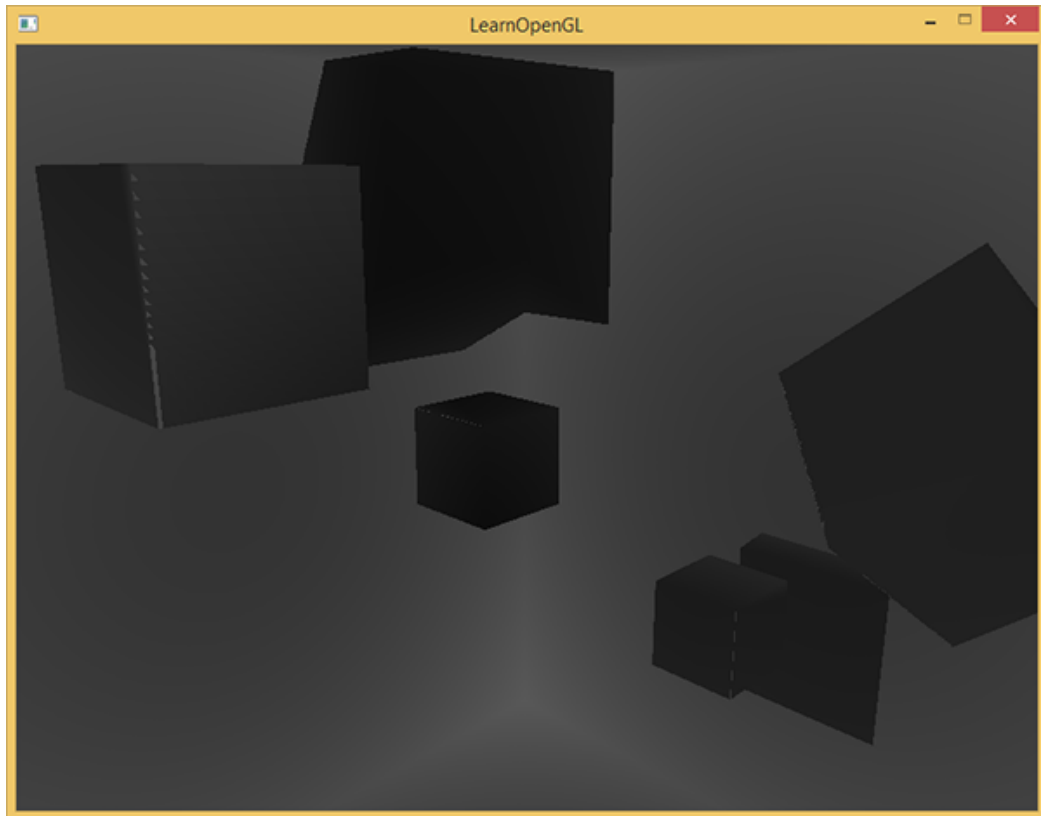

You can also see the to-be shadowed regions on the outside wall. If it looks somewhat similar you know the depth cubemap was properly generated. Otherwise you probably did something wrong or used the `closestDepth` still in the `[0, far_plane]` range.

36.3 PCF

Since omnidirectional shadow maps are based on the same principles of traditional shadow mapping it also has the same resolution dependent artifacts. If you zoom in closely you can again see jagged edges. [Percentage-closer filtering](#) or PCF allows us to smooth out these jagged edges by filtering multiple samples around the fragment position and average the results.

If we take the same simple PCF filter of the previous tutorial and add a third dimension (because we need 3D direction vectors to sample from a cubemap) we get:

```
float shadow = 0.0;
float bias = 0.05;
float samples = 4.0;
float offset = 0.1;
for(float x = -offset; x < offset; x += offset / (samples * 0.5))
{
    for(float y = -offset; y < offset; y += offset / (samples * 0.5))
    {
        for(float z = -offset; z < offset; z += offset / (samples * 0.5))
        {
            float closestDepth = texture(depthMap, fragToLight + vec3(x, y,
z)).r;
            closestDepth *= far_plane; // Undo mapping [0;1]
            if(currentDepth - bias > closestDepth)
```

```

        shadow += 1.0;
    }
}
shadow /= (samples * samples * samples);

```

The code isn't too different from what we had in traditional shadow mapping. Here we calculate the texture offsets dynamically based on the number of samples we'd like to take in each axis and take 3 times `sample` the amount of sub-samples that we then average at the end.

The shadows now look a lot more soft and smooth and gives much more plausible results.



However, with `samples` set to `4.0` we take a total of `64` samples each fragment which is a lot!

As most of these samples are redundant in that they sample close to the original direction vector it might make more sense to only sample in perpendicular directions of the sample direction vector. However as there is no (easy) way to figure out which sub-directions are redundant this becomes difficult. One trick we can use is to take an array of offset directions that are all roughly separable e.g. each of them points in completely different directions, reducing the number of sub-directions that are close together. Below we have such an array of a maximum of `20` offset directions:

```

vec3 sampleOffsetDirections[20] = vec3[]
(
    vec3( 1, 1, 1), vec3( 1, -1, 1), vec3(-1, -1, 1), vec3(-1, 1, 1),
    vec3( 1, 1, -1), vec3( 1, -1, -1), vec3(-1, -1, -1), vec3(-1, 1, -1),
    vec3( 1, 1, 0), vec3( 1, -1, 0), vec3(-1, -1, 0), vec3(-1, 1, 0),
    vec3( 1, 0, 1), vec3(-1, 0, 1), vec3( 1, 0, -1), vec3(-1, 0, -1),

```

```
vec3( 0, 1, 1), vec3( 0, -1, 1), vec3( 0, -1, -1), vec3( 0, 1, -1)
);
```

Then we can adapt the PCF algorithm to take a fixed amount of samples from `sampleOffsetDirections` and use these to sample the cubemap. The advantage is that we need a lot less samples to get visually similar results to the first PCF algorithm.

```
float shadow = 0.0;
float bias = 0.15;
int samples = 20;
float viewDistance = length(viewPos - fragPos);
float diskRadius = 0.05;
for(int i = 0; i < samples; ++i)
{
    float closestDepth = texture(depthMap, fragToLight +
    sampleOffsetDirections[i] * diskRadius).r;
    closestDepth *= far_plane; // Undo mapping [0;1]
    if(currentDepth - bias > closestDepth)
        shadow += 1.0;
}
shadow /= float(samples);
```

Here we add offsets to a specific `diskRadius` around the original `fragToLight` direction vector to sample from the cubemap.

Another interesting trick we can apply here is that we can change the `diskRadius` based on how far the viewer is away from a fragment; this way we can increase the offset radius by the distance to the viewer, making the shadows softer when far away and sharper when close by.

```
float diskRadius = (1.0 + (viewDistance / far_plane)) / 25.0;
```

The results of this PCF algorithm gives just as good, if not better, results of soft shadows:

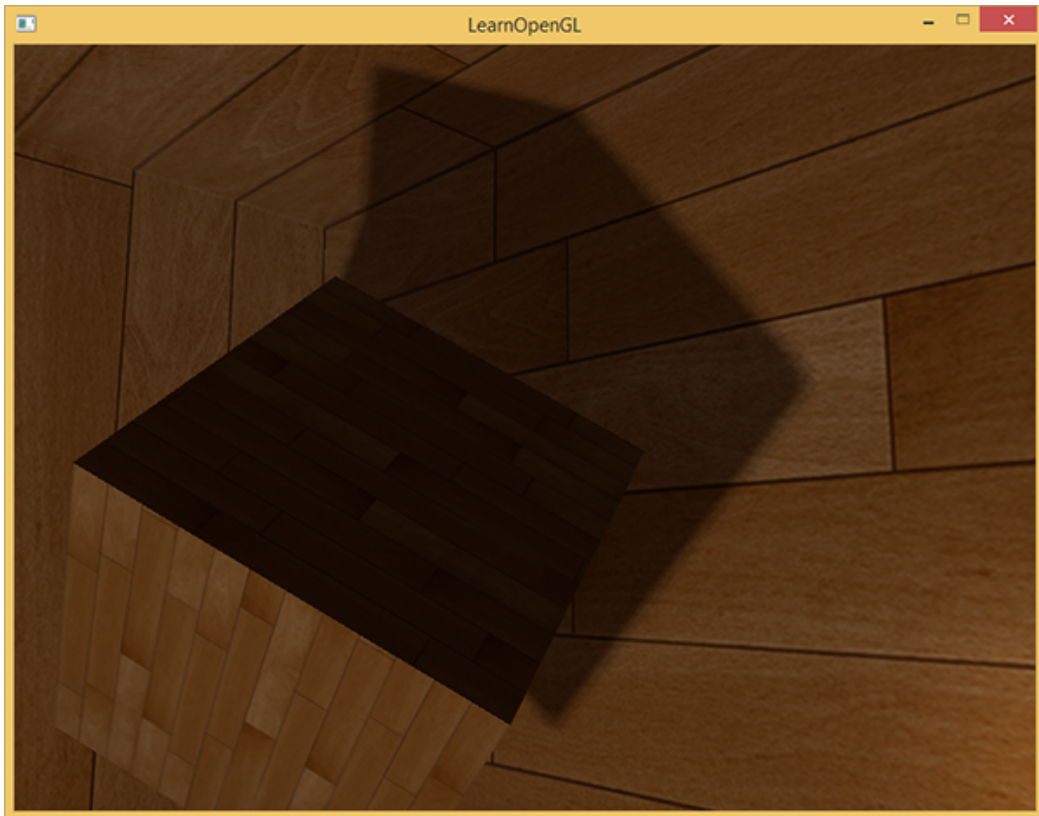

Of course, the `bias` we add to each sample is highly based on context and will always require tweaking based on the scene you're working with. Play around with all the values and see how they affect the scene.

You can find the final shaders here: [vertex](#) and [fragment](#).

I should mention that using geometry shaders to generate a depth map isn't necessarily faster than rendering the scene 6 times for each face. Using a geometry shader like this has its own performance penalties that might outweigh the performance gain of using one in the first place. This of course depends on the type of environment, the specific video card drivers and more so if you really care about performance, make sure to profile both methods and select the more efficient one for your scene. I personally prefer using geometry shaders for shadow mapping, simply because I find them more intuitive to use.

36.4 Additional resources

- [Shadow Mapping for point light sources in OpenGL](#): omnidirectional shadow mapping tutorial by sunandblackcat.
- [Multipass Shadow Mapping With Point Lights](#): omnidirectional shadow mapping tutorial by ogldev.
- [Omni-directional Shadows](#): a nice set of slides about omnidirectional shadow mapping by Peter Houska.

37. Normal Mapping

All our scenes are filled with polygons, each consisting of hundreds or maybe thousands of flat triangles. We boosted the realism by pasting 2D textures on these flat triangles to give them extra details, hiding the fact that the polygons actually consist of tiny flat triangles. Textures help, but when you take a good close look at them it is still quite easy to see the underlying flat surfaces. Most real-life surface are not flat however and exhibit a lot of (bumpy) details.

For instance, take a brick surface. A brick surface is quite a rough surface and obviously not completely flat: it contains sunken cement stripes and a lot of detailed little holes and cracks. If we were to view such a brick surface in a lighted scene the immersion gets easily broken. Below we can see a brick texture applied to a flat surface lighted by a point light.

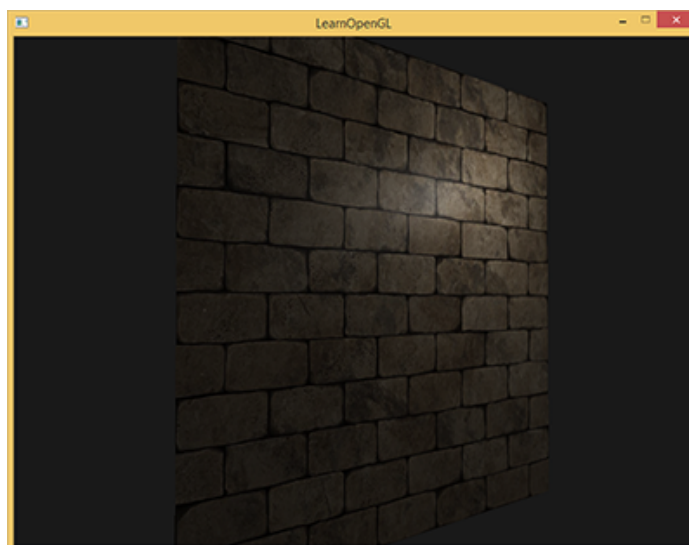

The lighting does not take any of the small cracks and holes into account and completely ignores the deep stripes between the bricks; the surface looks perfectly flat. We can partly solve the

flatness by using a specular map to pretend some surfaces are less lit due to depth or other details, but that's more of a hack than a real solution. What we need is some way to inform the lighting system about all the little depth-like details of the surface.

If we think about this from a light's perspective: how comes the surface is lit as a completely flat surface? The answer is the surface's normal vector. From the lighting algorithm's point of view the only way it determines the shape of an object is by its perpendicular normal vector. The brick surface only has a single normal vector and as a result the surface is uniformly lit based on this normal vector's direction. What if we, instead of a per-surface normal that is the same for each fragment, use a per-fragment normal that is different for each fragment? This way we can slightly deviate the normal vector based on a surface's little details; as a result this gives the illusion the surface is a lot more complex:

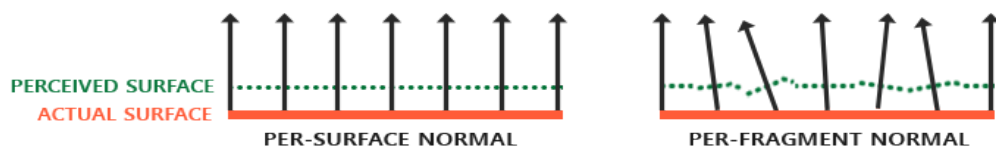

By using per-fragment normals we can trick the lighting into believing a surface consists of tiny little planes (perpendicular to the normal vectors) giving the surface an enormous boost in detail. This technique to use per-fragment normals compared to per-surface normals is called **normal mapping** or **bump mapping**. Applied to the brick plane it looks a bit like this:

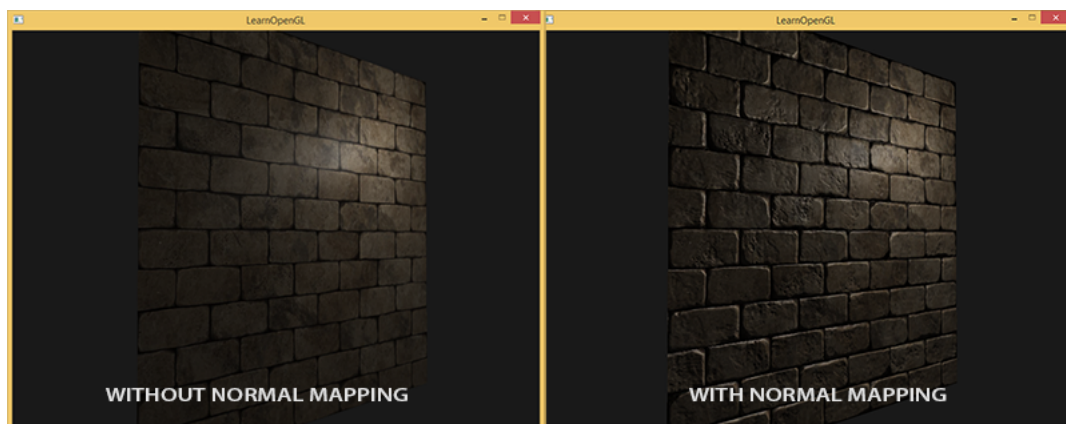

As you can see it gives an enormous boost in detail and for a relatively low cost. Because we only change the normal vectors per fragment there is no need to change any lighting equation. We now pass a per-fragment normal instead of an interpolated surface normal to the lighting algorithm. The lighting is then what gives a surface its detail.

37.1 Normal mapping

To get normal mapping to work we're going to need a per-fragment normal. Similar to what we did with diffuse maps and specular maps we can use a 2D texture to store per-fragment data. Aside from color and lighting data we can also store normal vectors in a 2D texture. This way we can sample from a 2D texture to get a normal vector for that specific fragment.

While normal vectors are geometric entities and textures are generally only used for color

information storing normal vectors in a texture might not be immediately obvious. If you think about color vectors in a texture they are represented as a 3D vector with an *r*, *g* and *b* component. We can similarly store a normal vector's *x*, *y* and *z* component in the respective color components. Normal vectors range between -1 and 1 so they're first mapped to $[0,1]$:

```
vec3 rgb_normal = normal * 0.5 + 0.5; // transforms from [-1,1] to [0,1]
```

With normal vectors transformed to an RGB color component like this we can store a per-fragment normal derived from the shape of a surface onto a 2D texture. An example **normal map** of the brick surface at the start of this tutorial is shown below:

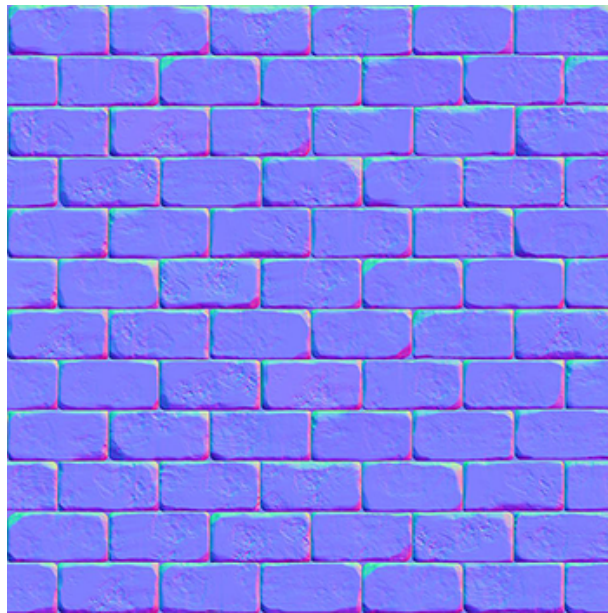

This (and almost all normal maps you find online) will have a blue-ish tint. This is because all the normals are all closely pointing outwards towards the positive *z*-axis which is $(0,0,1)$: a blue-ish color. The slight deviations in color represent normal vectors that are slightly offset from the general positive *z* direction, giving a sense of depth to the texture. For example, you can see that at the top of each brick the color tends to get more green which makes sense as the top side of a brick would have normals pointing more in the positive *y* direction $(0,1,0)$ which happens to be the color green!

With a simple plane looking at the positive *z*-axis we can take [this](#) diffuse texture and [this](#) normal map to render the image from the previous section. Note that the linked normal map is different from the one shown above. The reason for this is that OpenGL reads texture coordinates with the *y* (or *V*) coordinates reversed from how textures are generally created. The linked normal map thus has its *y* (or green) component reversed (you can see the green colors are now pointing downwards); if you fail to take this into account the lighting will be incorrect. Load both textures, bind them to the proper texture units and render a plane with the following changes in a lighting fragment shader:

```
uniform sampler2D normalMap;

void main()
{
    // Obtain normal from normal map in range [0,1]
```



```
normal = texture(normalMap, fs_in.TexCoords).rgb;
// Transform normal vector to range [-1,1]
normal = normalize(normal * 2.0 - 1.0);

[...]
// proceed with lighting as normal
}
```

Here we reverse the process of mapping normals to RGB colors by remapping the sampled normal color from $[0,1]$ back to $[-1,1]$ and then use the sampled normal vectors for the upcoming lighting calculations. In this case we used a Blinn-Phong shader.

By slowly moving the light source over time you really get a sense of depth using the normal map. Running this normal mapping example gives the exact results as shown at the start of this tutorial:

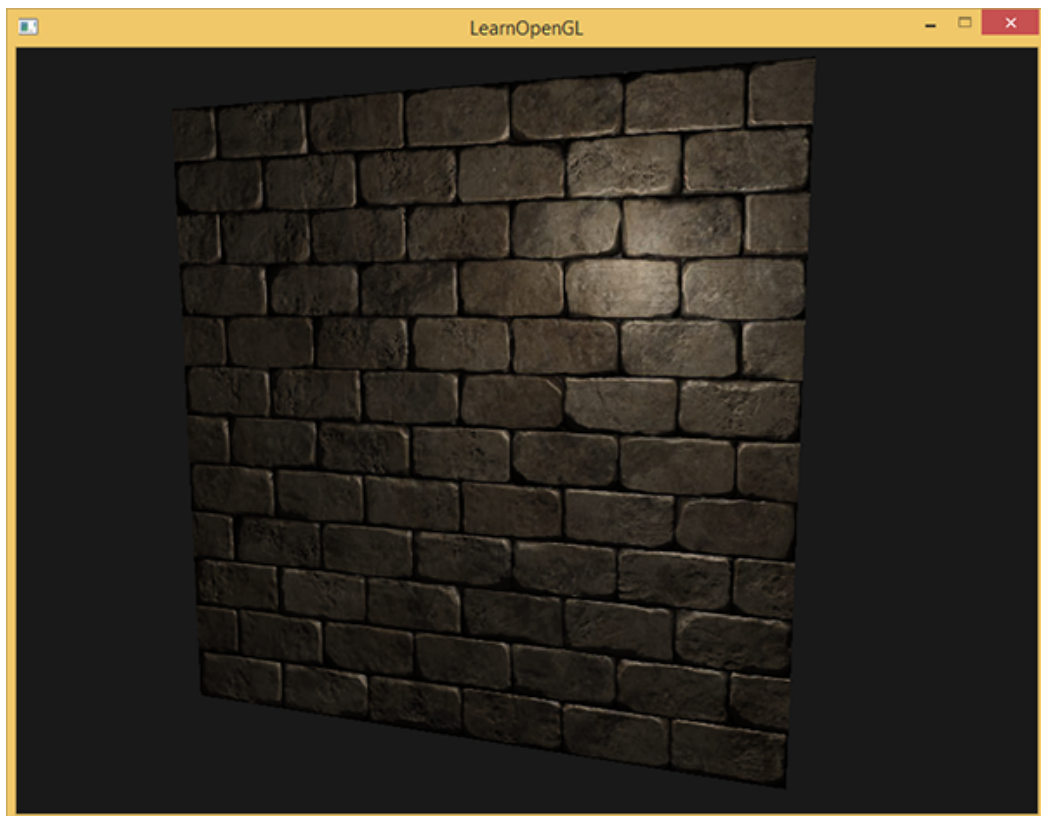

You can find the full source code of this simple demo [here](#) together with its [vertex](#) and [fragment](#) shader.

There is one issue however that greatly limits this use of normal maps. The normal map we used had normal vectors that all roughly pointed in the positive z direction. This worked because the plane's surface normal was also pointing in the positive z direction. However, what would happen if we used the same normal map on a plane laying on the ground with a surface normal vector pointing in the positive y direction?

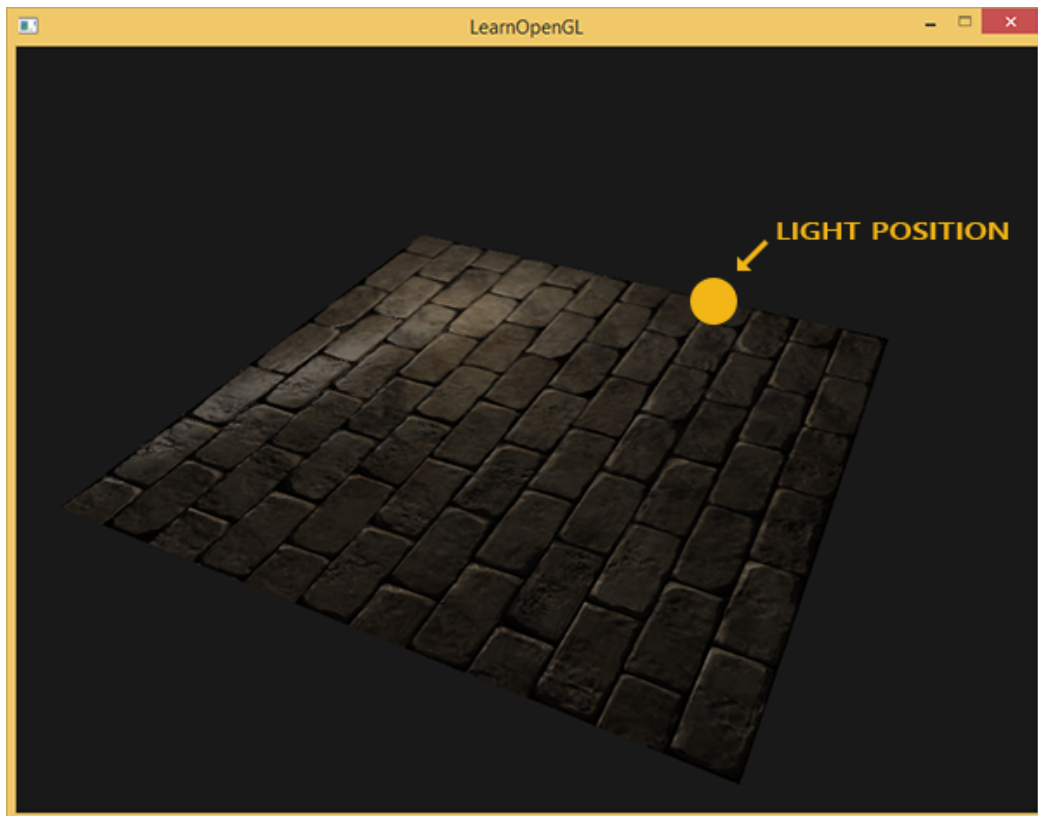

The lighting doesn't look right! This happens because the sampled normals of this plane still point roughly in the positive z direction even though they should point somewhat in the positive y direction of the surface normal. As a result the lighting thinks the surface's normals are the same as before when the surface was still looking in the positive z direction; the lighting is incorrect. The image below shows what the sampled normals approximately look like on this surface:

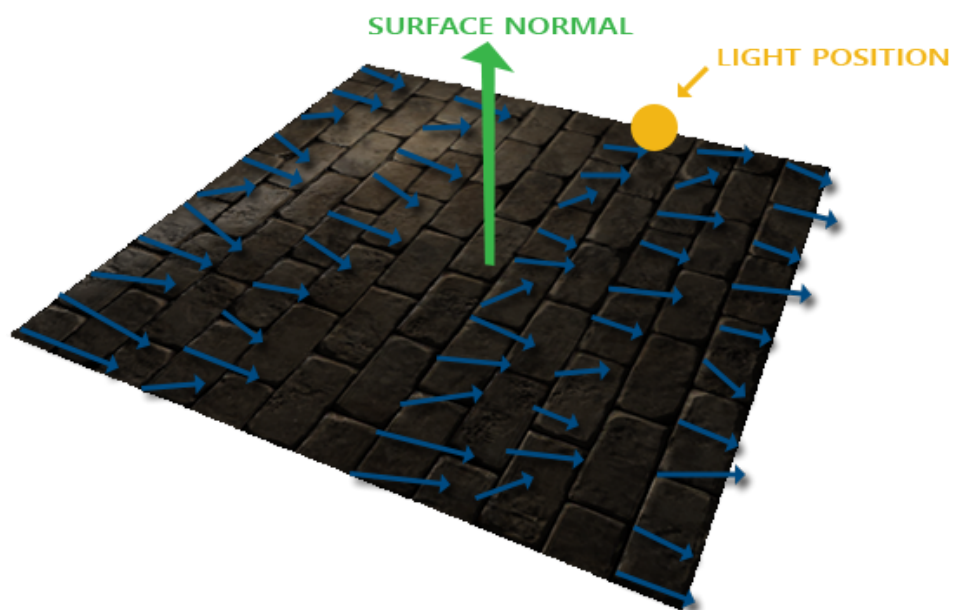

You can see that all the normals roughly point in the positive z direction while they should be pointing alongside the surface normal in the positive y direction. A possible solution to this

problem is to define a normal map for each possible direction of a surface. In the case of a cube we would need 6 normal maps, but with advanced models that can have more than hundreds of possible surface directions this becomes an infeasible approach.

A different and also slightly more difficult solution works by doing lighting in a different coordinate space: a coordinate space where the normal map vectors always point roughly in the positive z direction; all other lighting vectors are then transformed relative to this positive z direction. This way we can always use the same normal map, regardless of orientation. This coordinate space is called **tangent space**.

37.2 Tangent space

Normal vectors in a normal map are expressed in tangent space where normals always point roughly in the positive z direction. Tangent space is a space that's local to the surface of a triangle: the normals are relative to the local reference frame of the individual triangles. Think of it as the local space of the normal map's vectors; they're all defined pointing in the positive z direction regardless of the final transformed direction. Using a specific matrix we can then transform normal vectors from this *local* tangent space to world or view coordinates, orienting them along the final mapped surface's direction.

Let's say we have the incorrect normal mapped surface from the previous section looking in the positive y direction. The normal map is defined in tangent space, so one way to solve the problem is to calculate a matrix to transform normals from tangent space to a different space such that they're aligned with the surface's normal direction: the normal vectors are then all pointing roughly in the positive y direction. The great thing about tangent space is that we can calculate such a matrix for any type of surface so that we can properly align the tangent space's z direction to the surface's normal direction.

Such a matrix is called a **TBN** matrix where the letters depict a **tangent**, **bitangent** and **normal** vector. These are the vectors we need to construct this matrix. To construct such a *change-of-basis* matrix that transforms a tangent-space vector to a different coordinate space we need three perpendicular vectors that are aligned along the surface of a normal map: an up, right and forward vector; similar to what we did in the **camera** tutorial.

We already know the up vector which is the surface's normal vector. The right and forward vector are the tangent and bitangent vector respectively. The following image of a surface shows all three vectors on a surface:

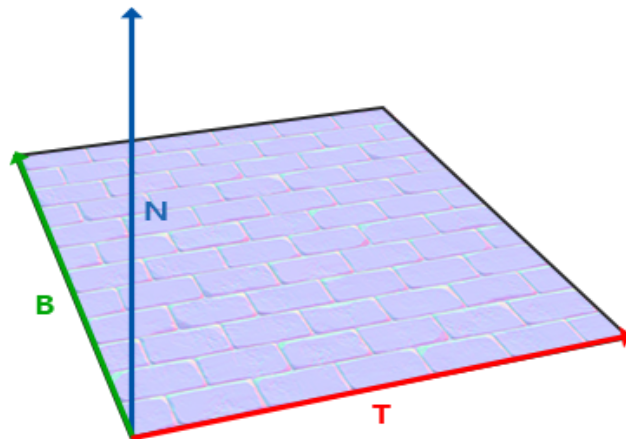

Calculating the tangent and bitangent vectors is not as straightforward as the normal vector. We can see from the image that the direction of the normal map's tangent and bitangent vector align with the direction in which we define a surface's texture coordinates. We'll use this fact to calculate tangent and bitangent vectors for each surface. Retrieving them does require a bit of math; take a look at the following image:

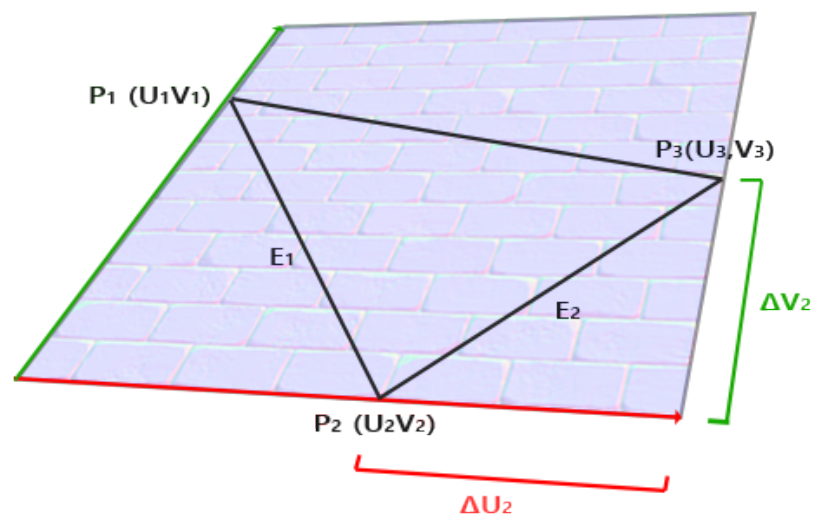

From the image we can see that the texture coordinate differences of an edge E_2 of a triangle denotes as ΔU_2 and ΔV_2 are expressed in the same direction as the tangent vector T and bitangent vector B . Because of this we can write both displayed edges E_1 and E_2 of the triangle as a linear combination of the tangent vector T and the bitangent vector B :

$$E_1 = \Delta U_1 T + \Delta V_1 B$$

$$E_2 = \Delta U_2 T + \Delta V_2 B$$

Which we can also write as:

$$(E_{1x}, E_{1y}, E_{1z}) = \Delta U_{1}(T_{x}, T_{y}, T_{z}) + \Delta V_{1}(B_{x}, B_{y}, B_{z})$$

$$(E_{2x}, E_{2y}, E_{2z}) = \Delta U_{2}(T_{x}, T_{y}, T_{z}) + \Delta V_{2}(B_{x}, B_{y}, B_{z})$$

We can calculate E as the difference vector between two vector positions and ΔU and ΔV as the texture coordinate differences. We're then left with two unknowns (tangent T and bitangent B) and two equations. You might remember from your algebra classes that this allows us to solve for T and B .

The last equations allow us to write it in a different form: that of matrix multiplication:

$$\begin{bmatrix} E_{1x} & E_{1y} & E_{1z} \\ E_{2x} & E_{2y} & E_{2z} \end{bmatrix} = \begin{bmatrix} \Delta U_{1} & \Delta V_{1} \\ \Delta U_{2} & \Delta V_{2} \end{bmatrix} \begin{bmatrix} T_{x} & T_{y} & T_{z} \\ B_{x} & B_{y} & B_{z} \end{bmatrix}$$

Try to visualize the matrix multiplications in your head and confirm that this is indeed the same equation. An advantage of rewriting the equations in matrix form is that solving for T and B becomes much more obvious. If we multiply both sides of the equations by the inverse of the $\Delta U \Delta V$ matrix we get:

$$\begin{bmatrix} \Delta U_{1} & \Delta V_{1} \\ \Delta U_{2} & \Delta V_{2} \end{bmatrix}^{-1} \begin{bmatrix} E_{1x} & E_{1y} & E_{1z} \\ E_{2x} & E_{2y} & E_{2z} \end{bmatrix} = \begin{bmatrix} T_{x} & T_{y} & T_{z} \\ B_{x} & B_{y} & B_{z} \end{bmatrix}$$

This allows us to solve for T and B . This does require us to calculate the inverse of the delta texture coordinate matrix. I won't go into the mathematical details of calculating a matrix' inverse, but it roughly translates to 1 over the determinant of the matrix multiplied by its adjugate matrix:

$$\begin{bmatrix} T_{x} & T_{y} & T_{z} \\ B_{x} & B_{y} & B_{z} \end{bmatrix} = \frac{1}{\Delta U_{1}\Delta V_{2} - \Delta U_{2}\Delta V_{1}} \begin{bmatrix} \Delta V_{2} & -\Delta V_{1} \\ -\Delta U_{2} & \Delta U_{1} \end{bmatrix} \begin{bmatrix} E_{1x} & E_{1y} & E_{1z} \\ E_{2x} & E_{2y} & E_{2z} \end{bmatrix}$$

This final equation gives us a formula for calculating the tangent vector T and bitangent vector B from a triangle's two edges and its texture coordinates.

Don't worry if you don't really understand the mathematics behind this. As long as you understand that we can calculate tangents and bitangents from a triangle's vertices and its texture coordinates (since texture coordinates are in the same space as tangent vectors) you're halfway there.

37.2.1 Manual calculation of tangents and bitangents

In the tutorial's demo scene we had a simple 2D plane looking at the positive z direction. This time we'd like to implement normal mapping using tangent space so we can orient this plane however we want and normal mapping would still work. Using the previously discussed mathematics we're going to manually calculate this surface's tangent and bitangent vectors.

Assuming the plane is built up from the following vectors (with 1, 2, 3 and 1, 3, 4 as its two triangles):

```
// positions
glm::vec3 pos1(-1.0, 1.0, 0.0);
glm::vec3 pos2(-1.0, -1.0, 0.0);
glm::vec3 pos3(1.0, -1.0, 0.0);
glm::vec3 pos4(1.0, 1.0, 0.0);
// texture coordinates
glm::vec2 uv1(0.0, 1.0);
glm::vec2 uv2(0.0, 0.0);
glm::vec2 uv3(1.0, 0.0);
glm::vec2 uv4(1.0, 1.0);
// normal vector
glm::vec3 nm(0.0, 0.0, 1.0);
```

We first calculate the first triangle's edges and delta UV coordinates:

```
glm::vec3 edge1 = pos2 - pos1;
glm::vec3 edge2 = pos3 - pos1;
glm::vec2 deltaUV1 = uv2 - uv1;
glm::vec2 deltaUV2 = uv3 - uv1;
```

With the required data for calculating tangents and bitangents we can start following the equation from the previous section:

```
GLfloat f = 1.0f / (deltaUV1.x * deltaUV2.y - deltaUV2.x * deltaUV1.y);

tangent1.x = f * (deltaUV2.y * edge1.x - deltaUV1.y * edge2.x);
tangent1.y = f * (deltaUV2.y * edge1.y - deltaUV1.y * edge2.y);
tangent1.z = f * (deltaUV2.y * edge1.z - deltaUV1.y * edge2.z);
tangent1 = glm::normalize(tangent1);

bitangent1.x = f * (-deltaUV2.x * edge1.x + deltaUV1.x * edge2.x);
bitangent1.y = f * (-deltaUV2.x * edge1.y + deltaUV1.x * edge2.y);
bitangent1.z = f * (-deltaUV2.x * edge1.z + deltaUV1.x * edge2.z);
bitangent1 = glm::normalize(bitangent1);

[...] // similar procedure for calculating tangent/bitangent for plane's
second triangle
```

Here we first pre-calculate the fractional part of the equation as f and then for each vector component we do the corresponding matrix multiplication multiplied by f . If you compare this code with the final equation you can see it is a direct translation. At the end we also do a normalization to make sure the tangent/bitangent vectors end up as unit vectors.

Because a triangle is always a flat shape we only need to calculate a single tangent/bitangent pair per triangle as they will be the same for each of the triangle's vertices. It should be noted that most implementations (e.g. model loaders and terrain generators) generally have triangles that share vertices with other triangles. In that case developers usually average the vertex properties like normals and tangents/bitangents for each vertex to get a more *smooth* result. Our plane's triangles also shares some vertices, but since both triangles are parallel to each other there's no need to average results, but it's good to keep this in mind whenever you encounter such a situation.

The resulting tangent and bitangent vector should have a value of (1,0,0) and (0,1,0) respectively that together with the normal (0,0,1) forms an orthogonal TBN matrix. Visualized on the plane the TBN vectors would look like this:

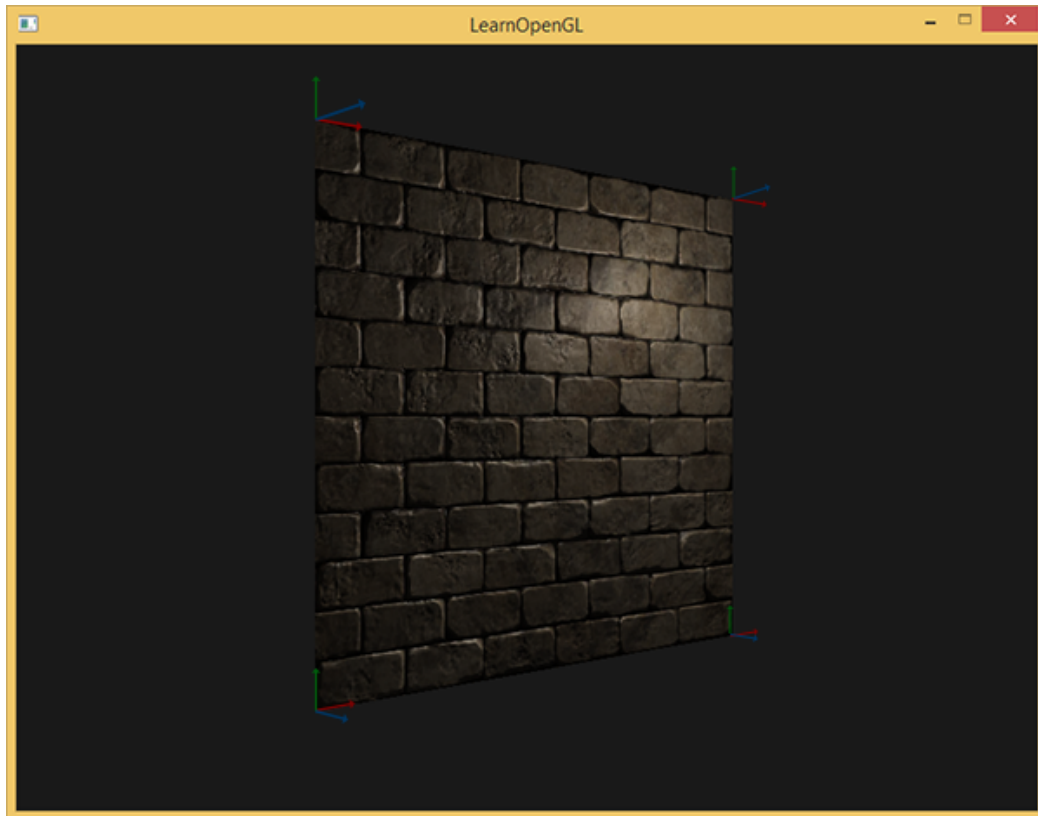

With tangent and bitangent vectors defined per vertex we can start implementing *proper* normal mapping.

37.2.2 Tangent space normal mapping

To get normal mapping working we first have to create a TBN matrix in the shaders. To do that we pass the earlier calculated tangent and bitangent vectors to the vertex shader as vertex attributes:

```
#version 330 core
layout (location = 0) in vec3 position;
layout (location = 1) in vec3 normal;
layout (location = 2) in vec2 texCoords;
layout (location = 3) in vec3 tangent;
layout (location = 4) in vec3 bitangent;
```

Then within the vertex shader's `main` function we create the TBN matrix:

```
void main()
{
    [...]
    vec3 T = normalize(vec3(model * vec4(tangent, 0.0)));
    vec3 B = normalize(vec3(model * vec4(bitangent, 0.0)));
    vec3 N = normalize(vec3(model * vec4(normal, 0.0)));
    mat3 TBN = mat3(T, B, N);
}
```

Here we first transform all the TBN vectors to the coordinate system we'd like to work in, which in this case is world-space as we multiply with just the `model` matrix. Then we create the actual TBN matrix by directly supplying `mat3`'s constructor with the relevant vectors. Note that if

we want to really be precise we wouldn't multiply the TBN vectors with the `model` matrix, but with the normal matrix as we only care about the orientation of the vectors and not translation and/or scaling transformations.

Technically there is no need for the `bitangent` variable in the vertex shader. All three TBN vectors are perpendicular to each other so we can calculate the `bitangent` ourselves in the vertex shader by simply taking the cross product of the `T` and `N` vector:

```
vec3 B = cross(T, N);
```

So now that we have a TBN matrix, how are we going to use it? There are basically two ways we can use a TBN matrix for normal mapping and we'll demonstrate both of them:

1. We take a TBN matrix that transforms any vector from tangent to world space, give it to the fragment shader and transform the sampled normal from tangent space to world space using the TBN matrix; the normal is then in the same space as the other lighting variables.
2. We take the inverse of the TBN matrix that transforms any vector from world space to tangent space and use this matrix to transform not the normal, but the other relevant lighting variables to tangent space; the normal is then again in the same space as the other lighting variables.

Let's review the first case. The normal vector we sample from the normal map is expressed in tangent space whereas the other lighting vectors (light and view pos) are expressed in world space. By passing the TBN matrix to the fragment shader we can multiply the sampled tangent space normal with this TBN matrix to transform the normal vector to the same reference space as the other lighting vectors. This way all the lighting calculations (specifically the dot product) make sense.

Sending the TBN matrix to the fragment shader is easy:

```
out VS_OUT {
    vec3 FragPos;
    vec2 TexCoords;
    mat3 TBN;
} vs_out;

void main()
{
    [...]
    vs_out.TBN = mat3(T, B, N);
}
```

In the fragment shader we similarly take a `mat3` as an input variable:

```
in VS_OUT {
    vec3 FragPos;
    vec2 TexCoords;
    mat3 TBN;
} fs_in;
```

With the TBN matrix we can now update the normal mapping code to include the tangent-to-world space transformation:

```
normal = texture(normalMap, fs_in.TexCoords).rgb;
```



```
normal = normalize(normal * 2.0 - 1.0);
normal = normalize(fs_in.TBN * normal);
```

Because the resulting `normal` is now in world space there is no need to change any of the other fragment shader code as the lighting code assumes the normal vector to be in world space.

Let's also review the second case, where we take the inverse of the TBN matrix to transform all relevant world-space vectors to the space the sampled normal vectors are in: tangent space. The construction of the TBN matrix remains the same, but we first inverse the matrix before sending it to the fragment shader:

```
vs_out.TBN = transpose(mat3(T, B, N));
```

Note that we use the `transpose` function instead of the `inverse` function here. A great property of orthogonal matrices (each axis is a perpendicular unit vector) is that the transpose of an orthogonal matrix is equal to its inverse. This is a great property as inverses are quite expensive and a transpose isn't; the results are the same.

Within the fragment shader we then do not transform the normal vector, but we transform the other relevant vectors to tangent space, namely the `lightDir` and `viewDir` vectors. That way each vector is again in the same coordinate system: tangent space.

```
void main()
{
    vec3 normal = texture(normalMap, fs_in.TexCoords).rgb;
    normal = normalize(normal * 2.0 - 1.0);

    vec3 lightDir = fs_in.TBN * normalize(lightPos - fs_in.FragPos);
    vec3 viewDir = fs_in.TBN * normalize(viewPos - fs_in.FragPos);
    [...]
}
```

The second approach seems like more work and also requires more matrix multiplications in the fragment shader (which are slightly expensive) so why would we bother with the second approach?

Well, transforming vectors from world to tangent space has an added advantage in that we can transform all the relevant vectors to tangent space in the vertex shader instead of in the fragment shader. This works, because `lightPos` and `viewPos` do not change each fragment run and for `fs_in.FragPos` we can also calculate its tangent-space position in the vertex shader and let fragment interpolation do its work. Basically, there is no need to transform any vector to tangent space in the fragment shader, while it is necessary with the first approach as sampled normal vectors are specific to each fragment shader run.

So instead of sending the inverse of the TBN matrix to the fragment shader, we send a tangent-space light position, view position and vertex position to the fragment shader. This saves us from matrix multiplications in the fragment shader. This is a nice optimization as the vertex shader runs considerably less often than the fragment shader. This is also the reason why this approach is often the preferred approach.

```
out VS_OUT {
```

```
vec3 FragPos;
vec2 TexCoords;
vec3 TangentLightPos;
vec3 TangentViewPos;
vec3 TangentFragPos;
} vs_out;

uniform vec3 lightPos;
uniform vec3 viewPos;

[...]

void main()
{
    [...]
    mat3 TBN = transpose(mat3(T, B, N));
    vs_out.TangentLightPos = TBN * lightPos;
    vs_out.TangentViewPos = TBN * viewPos;
    vs_out.TangentFragPos = TBN * vec3(model * vec4(position, 0.0));
}
```

In the fragment shader we then use these new input variables to calculate lighting in tangent space. As the normal vector is already in tangent space the lighting makes sense.

With normal mapping applied in tangent space we should get similar results to what we had at the start of this tutorial, but this time we can orient our plane in any way we'd like and the lighting would still be correct:

```
glm::mat4 model;
model = glm::rotate(model, (GLfloat)glfwGetTime() * -10, glm::normalize(glm::vec3(1.0, 0.0, 1.0)));
glUniformMatrix4fv(modelLoc 1, GL_FALSE, glm::value_ptr(model));
RenderQuad();
```

Which indeed looks like proper normal mapping:

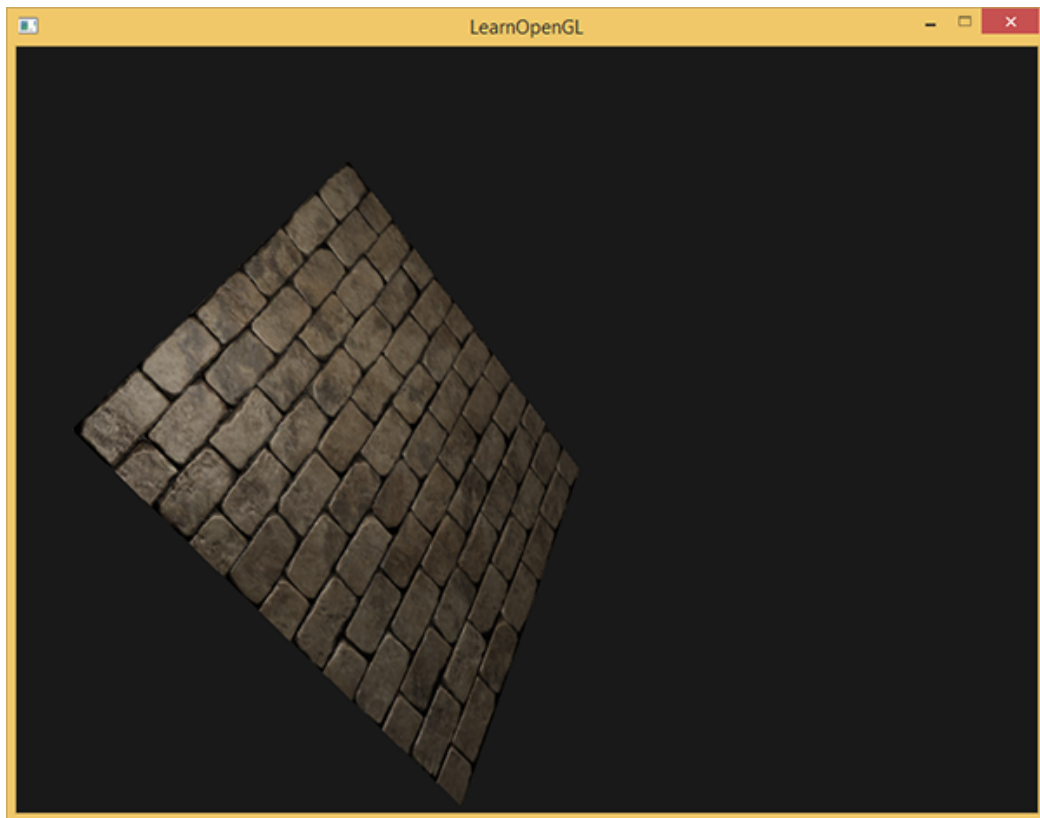

You can find the source code [here](#) together with its [vertex](#) and [fragment](#) shader.

37.3 Complex objects

We've demonstrated how we can use normal mapping together with tangent space transformations by manually calculating the tangent and bitangent vectors. Luckily for us, having to manually calculate these tangent and bitangent vectors is not something you do too often; most of the time you implement it once in a custom model loader or in our case use a [model loader](#) using Assimp.

Assimp has a very useful configuration bit we can set when loading a model called `aiProcess_CalcTangentSpace`. When the `aiProcess_CalcTangentSpace` bit is supplied to Assimp's `ReadFile` function Assimp calculates smooth tangent and bitangent vectors for each of the loaded vertices, similarly to how we did it in this tutorial.

```
const aiScene* scene = importer.ReadFile(
    path, aiProcess_Triangulate | aiProcess_FlipUVs |
    aiProcess_CalcTangentSpace
);
```

Within Assimp we can then retrieve the calculated tangents via:

```
vector.x = mesh->mTangents[i].x;
vector.y = mesh->mTangents[i].y;
vector.z = mesh->mTangents[i].z;
vertex.Tangent = vector;
```

Then you'll also have to update the model loader to also load normal maps from a textured model. The wavefront object format (.obj) exports normal maps slightly different as Assimp's `aiTextureType_NORMAL` doesn't load its normal maps while `aiTextureType_HEIGHT` does so I often load them as:

```
vector<Texture> specularMaps = this->loadMaterialTextures(
    material, aiTextureType_HEIGHT, "texture_normal"
);
```

Of course this is different for each type of loaded model and file format. Also important to realize is that `aiProcess_CalcTangentSpace` doesn't always work. Calculating tangents is based on texture coordinates and some model artists do certain texture tricks like mirroring a texture surface over a model by also mirroring half of the texture coordinates; this gives incorrect results when the mirroring is not taken into account (which Assimp doesn't).

Running the application on a model that is properly texture mapped with specular and normal maps using an updated model loader gives a result a bit like this:



As you can see normal mapping boosts the detail of an object by an incredible amount without too much extra cost.

Using normal maps is also a great way to boost the performance of your scene. Before normal mapping you had to use a large number of vertices to present a high number of detail on a mesh, but with normal mapping we can present the same level of detail on a mesh using a lot less vertices. The image below from Paolo Cignoni shows a nice comparison of both methods:

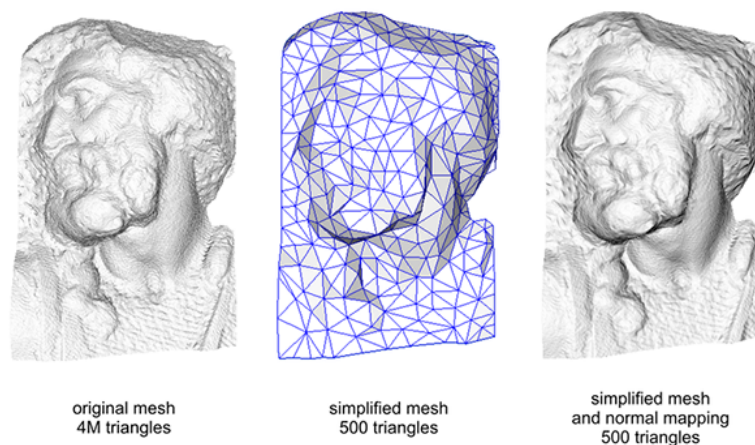

The details on both the high-vertex mesh and the low-vertex mesh with normal mapping are almost indistinguishable. So normal mapping doesn't only look nice, it is also a great tool to replace high-vertex polygons with low-vertex polygons without losing detail.

37.4 One last thing

There is one last trick I'd like to discuss with regards to normal mapping that slightly improves its quality without too much extra cost.

When tangent vectors are calculated on larger meshes that share a considerable amount of vertices the tangent vectors are generally averaged to give nice and smooth results when normal mapping is applied to these surfaces. A problem with this approach is that the three TBN vectors could end up non-perpendicular to each other which means the resulting TBN matrix would no longer be orthogonal. Normal mapping will be only slightly off with a non-orthogonal TBN matrix, but it's still something we can improve.

Using a mathematical trick called the [Gram-Schmidt process](#) we can [re-orthogonalize](#) the TBN vectors such that each vector is again perpendicular to the other vectors. Within the vertex shader we would do it like this:

```
vec3 T = normalize(vec3(model * vec4(tangent, 0.0)));
vec3 N = normalize(vec3(model * vec4(normal, 0.0)));
// re-orthogonalize T with respect to N
T = normalize(T - dot(T, N) * N);
// then retrieve perpendicular vector B with the cross product of T and N
vec3 B = cross(T, N);

mat3 TBN = mat3(T, B, N)
```

This, albeit by a little, generally improves the normal mapping results with a little extra cost. Take a look at the end of the *Normal Mapping Mathematics* video referenced below this tutorial for a great explanation of how this process actually works.

37.5 Additional resources

- [Tutorial 26: Normal Mapping](#): normal mapping tutorial by ogldev.
- [How Normal Mapping Works](#): a nice video tutorial of how normal mapping works by TheBennyBox.
- [Normal Mapping Mathematics](#): a similar video by TheBennyBox about the mathematics behind normal mapping.
- [Tutorial 13: Normal Mapping](#): normal mapping tutorial by opengl-tutorial.org.

38. Parallax Mapping

Parallax mapping is a technique similar to normal mapping, but based on different principles. Similar to normal mapping it is a technique that significantly boosts a textured surface's detail and gives it a sense of depth. While also an illusion, parallax mapping is a lot better in conveying a sense of depth and together with normal mapping gives incredibly realistic results. While parallax mapping isn't necessarily a technique directly related to (advanced) lighting, I'll still discuss it here as the technique is a logical follow-up of normal mapping. Note that getting an understanding of normal mapping, specifically tangent space, is strongly advised before learning parallax mapping.

Parallax mapping belongs to the family of **displacement mapping** techniques that *displace* or *offset* vertices based on geometrical information stored inside a texture. One way to do this is to take a plane with roughly 1000 vertices and displace each of these vertices based on a value in a texture that tells us the height of the plane at a specific area. Such a texture that contains height values per texel is called a **height map**. An example height map derived from the geometric properties of a simple brick surface looks a bit like this:

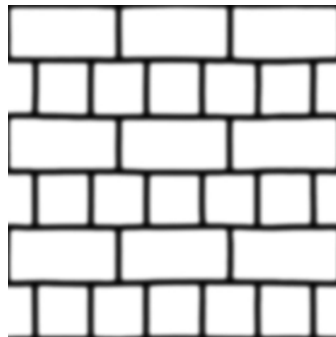

When spanned over a plane each vertex is displaced based on the sampled height value in the height map, transforming a flat plane to a rough bumpy surface based on a material's geometric properties. For instance, taking a flat plane displaced with the above heightmap results in the following image:

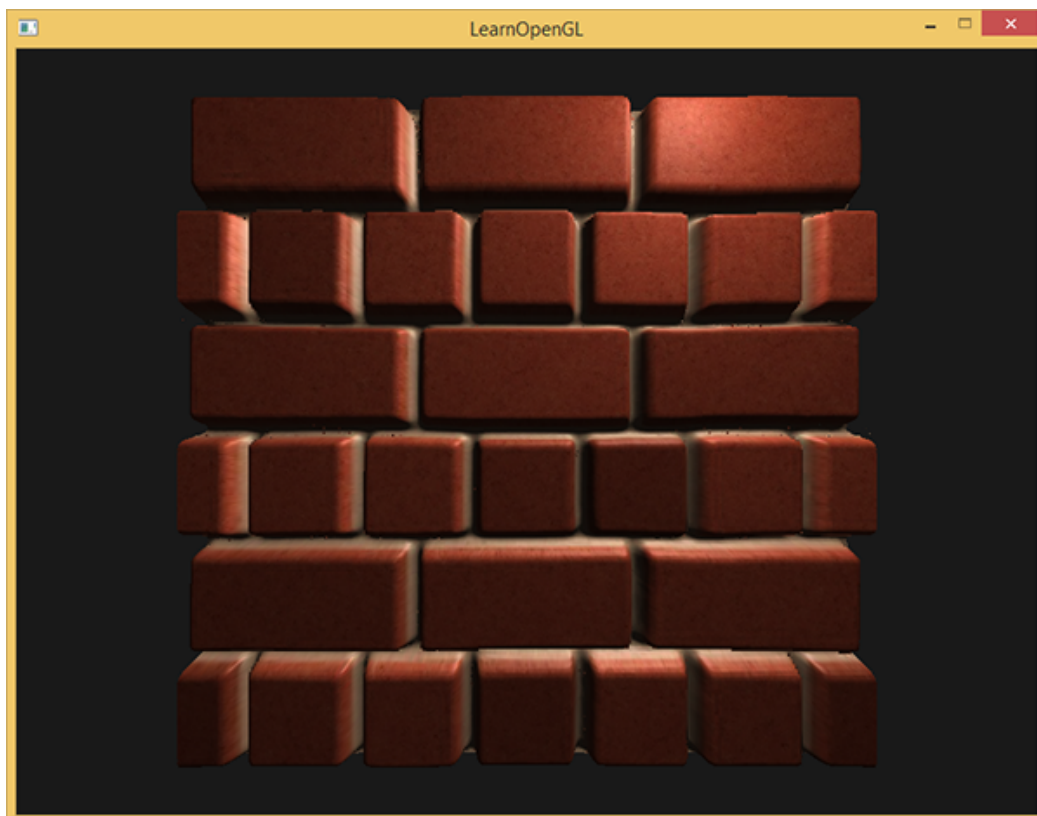

A problem with displacing vertices is that a plane needs to consist of a large amount of triangles to get a realistic displacement otherwise the displacement looks too blocky. As each flat surface could then require over 1000 vertices this quickly becomes computationally infeasible. What if we could somehow achieve similar realism without the need of extra vertices? In fact, what if I were to tell you that the above displaced surface is actually rendered with only 6 vertices (or 2 triangles)? This brick surface shown is rendered with **parallax mapping**, a displacement mapping technique that doesn't require extra vertex data to convey depth, but similar to normal mapping uses a clever technique to trick the user.

The idea behind parallax mapping is to alter the texture coordinates in such a way that it looks like a fragment's surface is higher or lower than it actually is, all based on the view direction and a heightmap. To understand how it works, take a look at the following image of our brick surface:

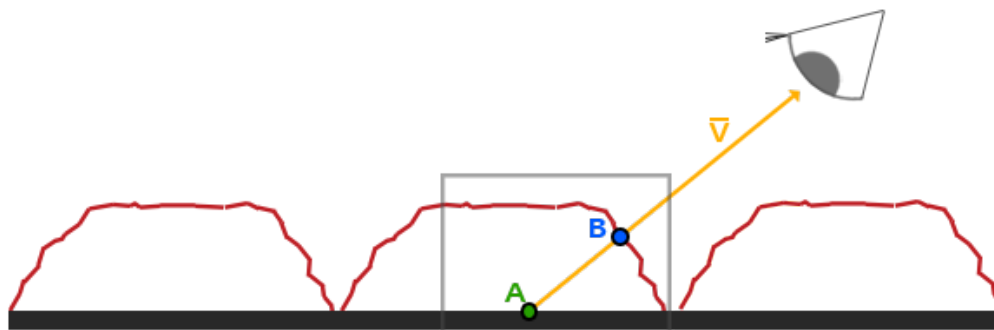

Here the rough red line represents the values in the heightmap as the geometric surface representation of the brick surface and the vector \vec{v} represents the surface to view direction (`viewDir`). If the plane would have actual displacement the viewer would see the surface at point

B . However, as our plane has no actual displacement the view direction hits the flat plane at point A as we'd expect. Parallax mapping aims to offset the texture coordinates at fragment position A in such a way that we get texture coordinates at point B . We then use the texture coordinates at point B for all subsequent texture samples, making it look like the viewer is actually looking at point B .

The trick is to figure out how to get the texture coordinates at point B from point A . Parallax mapping tries to solve this by scaling the fragment-to-view direction vector \vec{V} by the height at fragment A . So we're scaling the length of \vec{V} to be equal to a sampled value from the heightmap $H(A)$ at fragment position A . The image below shows this scaled vector \vec{P} :

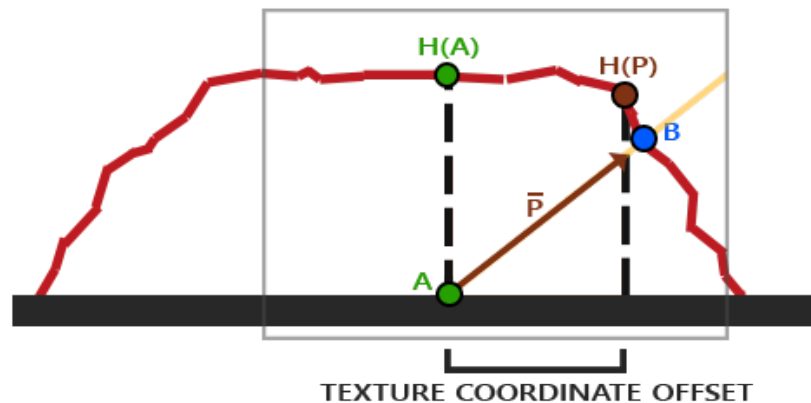

We then take this vector \vec{P} and take its vector coordinates that align with the plane as the texture coordinate offset. This works because vector \vec{P} is calculated using a height value from the heightmap so the higher a fragment's height, the more it effectively gets displaced.

This little trick gives good results most of the time, but is however a really crude approximation to get to point B . When heights change rapidly over a surface the results tend to look unrealistic as the vector \vec{P} will not end up close to B as you can see below:

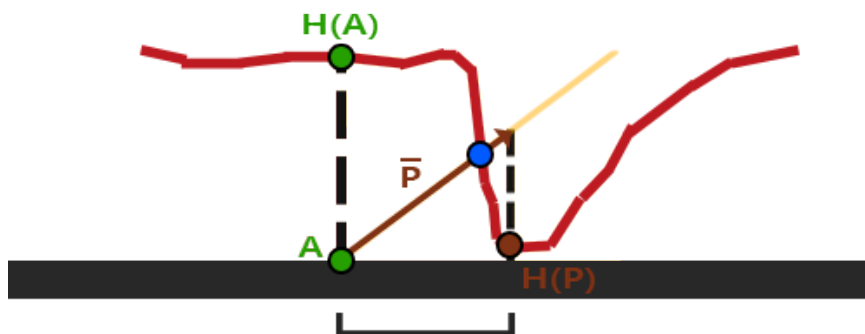

Another issue with parallax mapping is that it's difficult to figure out which coordinates to retrieve from \vec{P} when the surface is arbitrarily rotated in some way. What we'd rather do is parallax mapping in a different coordinate space where the x and y component of vector \vec{P} always aligns with the texture's surface. If you've followed along in the [normal mapping](#) tutorial you probably guessed how we can accomplish this and yes, we would like to do parallax mapping in tangent space.

By transforming the fragment-to-view direction vector \vec{V} to tangent space the transformed

\vec{P} vector will have its x and y component aligned to the surface's tangent and bitangent vectors. As the tangent and bitangent vectors are pointing in the same direction as the surface's texture coordinates we can take the x and y components of \vec{P} as the texture coordinate offset, regardless of the surface's direction.

But enough about the theory, let's get our feet wet and start implementing actual parallax mapping.

38.1 Parallax mapping

For parallax mapping we're going to use a simple 2D plane of which we calculate its tangent and bitangent vectors before sending it to the GPU; similar to what we did in the normal mapping tutorial. Onto the plane we're going to attach a [diffuse texture](#), a [normal map](#) and a [displacement map](#) that you can download yourself by clicking the respective links. For this example we're going to use parallax mapping in conjunction with normal mapping. Because parallax mapping gives the illusion that it displaces a surface, the illusion breaks when the lighting doesn't match. As normal maps are often generated from heightmaps, using a normal map together with the heightmap makes sure the lighting is in place with the displacement.

You might've already noted that the displacement map linked above is the inverse of the heightmap shown at the start of this tutorial. With parallax mapping it makes more sense to use the inverse of the heightmap (also known as a [depthmap](#)) as it's easier to fake depth than height on flat surfaces. This slightly changes how we perceive parallax mapping as shown below:

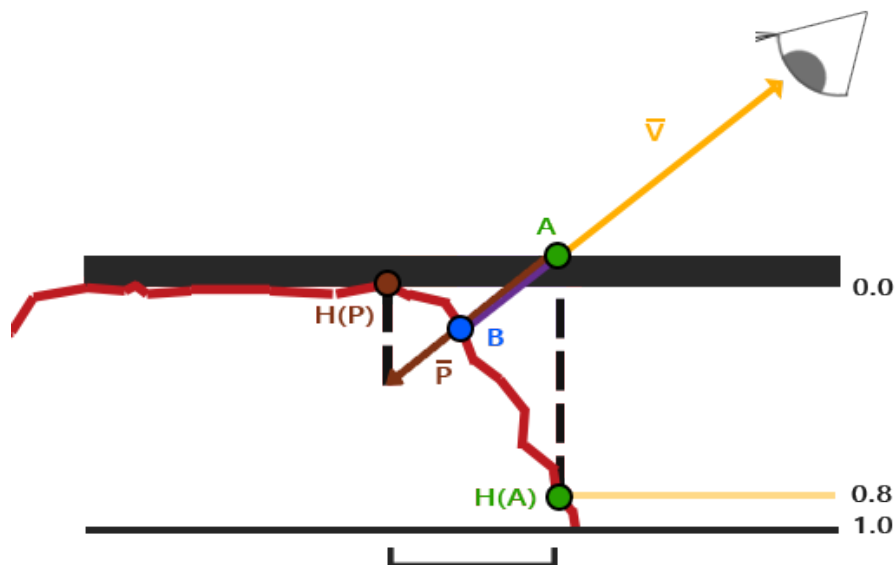

We again have a points A and B , but this time we obtain vector \vec{P} by **subtracting** vector \vec{V} from the texture coordinates at point A . We can obtain depth values instead of height values by subtracting the sampled heightmap values from 1.0 in the shaders, or by simply inverting its texture values in image-editing software as we did with the depthmap linked above.

Parallax mapping is implemented in the fragment shader as the displacement effect differs all over a triangle's surface. In the fragment shader we're then going to need to calculate the fragment-to-view direction vector \vec{V} so we need the view position and a fragment position in

tangent space. In the normal mapping tutorial we already had a vertex shader that sends these vectors in tangent space so we can take an exact copy of that tutorial's vertex shader:

```
#version 330 core
layout (location = 0) in vec3 position;
layout (location = 1) in vec3 normal;
layout (location = 2) in vec2 texCoords;
layout (location = 3) in vec3 tangent;
layout (location = 4) in vec3 bitangent;

out VS_OUT {
    vec3 FragPos;
    vec2 TexCoords;
    vec3 TangentLightPos;
    vec3 TangentViewPos;
    vec3 TangentFragPos;
} vs_out;

uniform mat4 projection;
uniform mat4 view;
uniform mat4 model;

uniform vec3 lightPos;
uniform vec3 viewPos;

void main()
{
    gl_Position = projection * view * model * vec4(position, 1.0f);
    vs_out.FragPos = vec3(model * vec4(position, 1.0));
    vs_out.TexCoords = texCoords;

    vec3 T = normalize(mat3(model) * tangent);
    vec3 B = normalize(mat3(model) * bitangent);
    vec3 N = normalize(mat3(model) * normal);
    mat3 TBN = transpose(mat3(T, B, N));

    vs_out.TangentLightPos = TBN * lightPos;
    vs_out.TangentViewPos = TBN * viewPos;
    vs_out.TangentFragPos = TBN * vs_out.FragPos;
}
```

What's important to note here is that for parallax mapping we specifically need to send the `position` and viewer's position `viewPos` in tangent space to the fragment shader.

Within the fragment shader we then implement the parallax mapping logic. The fragment shader looks a bit like this:

```
#version 330 core
out vec4 FragColor;

in VS_OUT {
    vec3 FragPos;
    vec2 TexCoords;
    vec3 TangentLightPos;
    vec3 TangentViewPos;
    vec3 TangentFragPos;
} fs_in;
```

```

uniform sampler2D diffuseMap;
uniform sampler2D normalMap;
uniform sampler2D depthMap;

uniform float height_scale;

vec2 ParallaxMapping(vec2 texCoords, vec3 viewDir);

void main()
{
    // Offset texture coordinates with Parallax Mapping
    vec3 viewDir = normalize(fs_in.TangentViewPos - fs_in.TangentFragPos);
    vec2 texCoords = ParallaxMapping(fs_in.TexCoords, viewDir);

    // then sample textures with new texture coords
    vec3 diffuse = texture(diffuseMap, texCoords);
    vec3 normal = texture(normalMap, texCoords);
    normal = normalize(normal * 2.0 - 1.0);
    // proceed with lighting code
    [...]
}

```

We defined a function called `ParallaxMapping` that takes as input the fragment's texture coordinates and the fragment-to-view direction \vec{V} in tangent space. The function returns the displaced texture coordinates. We then use these *displaced* texture coordinates as the texture coordinates for sampling the diffuse and normal map. As a result the fragment's diffuse color and normal vector correctly corresponds to the surface's displaced geometry.

Let's take a look inside the `ParallaxMapping` function:

```

vec2 ParallaxMapping(vec2 texCoords, vec3 viewDir)
{
    float height = texture(depthMap, texCoords).r;
    vec3 p = viewDir.xy / viewDir.z * (height * height_scale);
    return texCoords - p;
}

```

This relatively simple function is a direct translation of what we've discussed so far. We take the original texture coordinates `texCoords` and use these to sample the height (or depth) from the `depthMap` at the current fragment $H(A)$. We then calculate \vec{P} as the x and y component of the tangent-space `viewDir` vector divided by its z component and scale it by the fragment's height. We also introduced a `height_scale` uniform for some extra control as the parallax effect is usually too strong without an extra scale parameter. We then subtract this vector \vec{P} from the texture coordinates to get the final displaced texture coordinates.

What is interesting to note here is the division of `viewDir.xy` by `viewDir.z`. As the `viewDir` vector is normalized `viewDir.z` will be somewhere in the range between 0.0 and 1.0. When `viewDir` is largely parallel to the surface its z component is close to 0.0 and the division returns a much larger vector \vec{P} compared to when `viewDir` is largely perpendicular to the surface. So basically we're increasing the size of \vec{P} in such a way that it offsets the texture coordinates at a larger scale when looking at a surface from an angle compared to when looking at it from the top; this gives more realistic results at angles.

Some people prefer to leave the division by `viewDir.z` out of the equation as normal Parallax Mapping could produce undesirable results at angles; the technique is then called **Parallax Mapping**

with [Offset Limiting](#). Choosing which technique to pick is usually a matter of personal preference, but I often tend to side with normal Parallax Mapping.

The resulting texture coordinates are then used to sample the other textures (diffuse and normal) and this gives a very neat displaced effect as you can see below with a `height_scale` of roughly 0.1:



Here you can see the difference between normal mapping and parallax mapping combined with normal mapping. Because parallax mapping tries to simulate depth it is actually possible to have bricks overlap other bricks based on the direction you view them.

You can still see some weird border artifacts at the edge of the parallax mapped plane. This happens because at the edges of the plane, the displaced texture coordinates could oversample outside the range $[0, 1]$ and this gives unrealistic results based on the texture's wrapping mode(s). A cool trick to solve this issue is to discard the fragment whenever it samples outside the default texture coordinate range:

```
texCoords = ParallaxMapping(fs_in.TexCoords, viewDir);
if(texCoords.x > 1.0 || texCoords.y > 1.0 || texCoords.x < 0.0 || texCoords
.y < 0.0)
    discard;
```

All fragments with (displaced) texture coordinates outside the default range get discarded and Parallax Mapping then gives proper result around the edges of a surface. Note that this trick doesn't work properly on all types of surfaces, but when applied to a plane it gives great results making it look like the plane is now actually displaced:

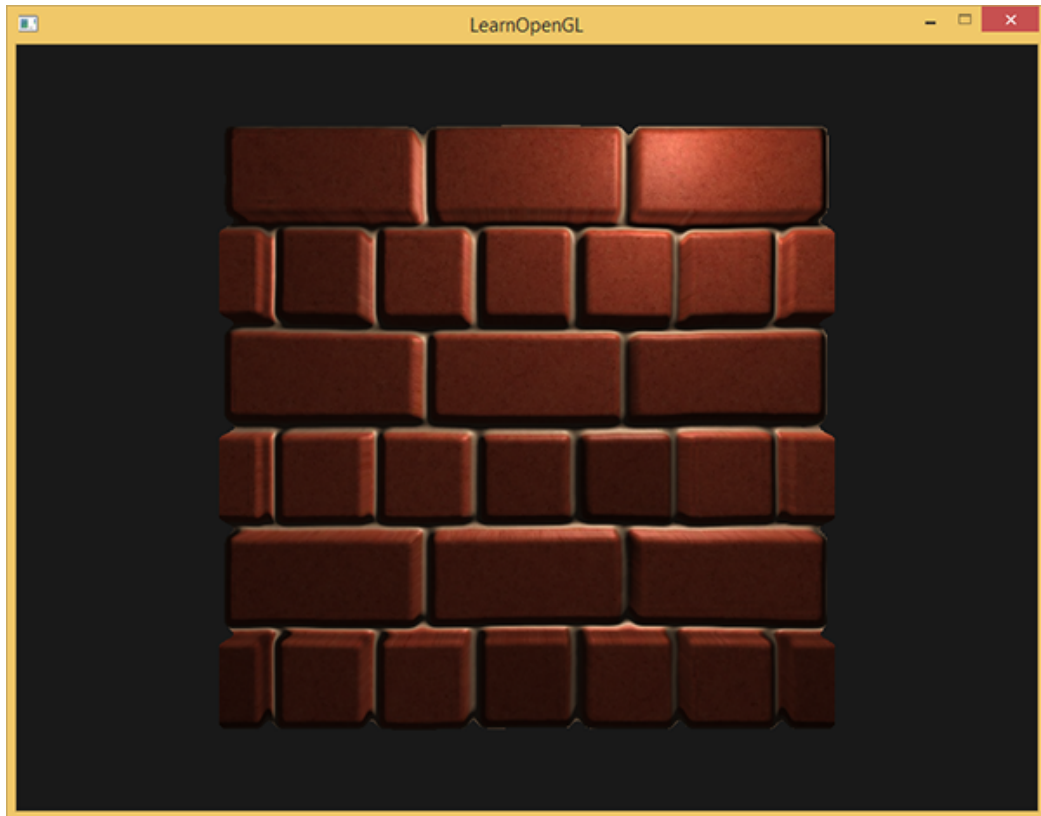

You can find the source code [here](#) together with its [vertex](#) and [fragment](#) shader.

It looks great and is quite fast as well as we only need a single extra texture sample for parallax mapping to work. It does come with a few issues though as it sort of breaks down when looking at it from an angle (similar to normal mapping) and gives incorrect results with steep height changes, as you can see below:

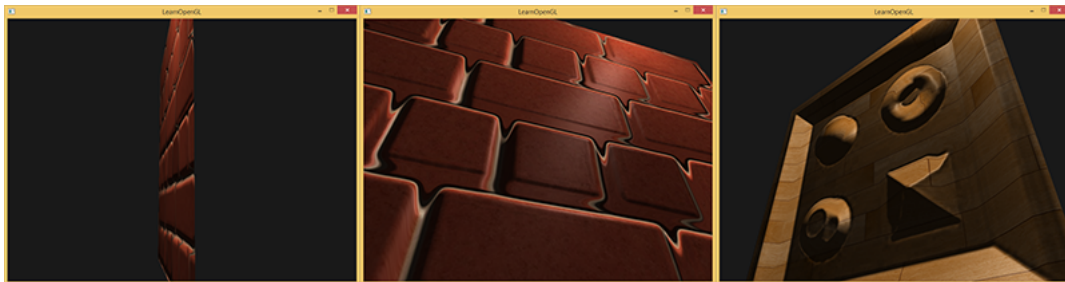

The reason that it doesn't work properly at times is that it's just a crude approximation of displacement mapping. There are some extra tricks however that still allows us to get almost perfect results with steep height changes, even when looking at an angle. For instance, what if we instead of one sample, take multiple samples to find the closest point to B ?

38.2 Steep Parallax Mapping

Steep Parallax Mapping is an extension on top of Parallax Mapping in that it uses the same principles, but instead of 1 sample it takes multiple samples to better pinpoint vector \vec{P} to B . This gives much better results, even with steep height changes as the accuracy of the technique is

improved by the number of samples.

The general idea of Steep Parallax Mapping is that it divides the total depth range into multiple layers of the same height/depth. For each of these layers we sample the depthmap shifting the texture coordinates along the direction of \vec{P} until we find a sampled depth value that is below the depth value of the current layer. Take a look at the following image:

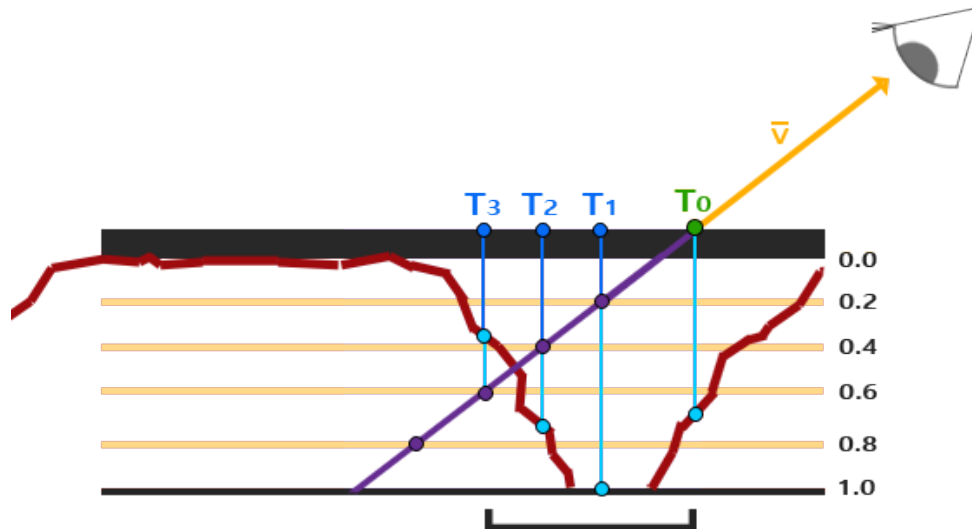

We traverse the depth layers from the top down and for each layer we compare its depth value to the depth value stored in the depthmap. If the layer's depth value is less than the depthmap's value it means this layer's part of vector \vec{P} is not below the surface. We continue this process until the layer's depth is higher than the value stored in the depthmap: this point is then below the (displaced) geometric surface.

In this example we can see that the depthmap value at the second layer ($D(2) = 0.73$) is still lower than the second layer's depth value 0.4 so we continue. In the next iteration the layer's depth value 0.6 does become higher than the depthmap's sampled depth value ($D(3) = 0.37$). We can thus assume vector \vec{P} at the third layer to be the most viable position of the displaced geometry. We can then take the texture coordinate offset T_3 from vector \vec{P}_3 to displace the fragment's texture coordinates. You can see how the accuracy increases with more depth layers.

To implement this technique we only have to change the `ParallaxMapping` function as we already have all the variables we need:

```
vec2 ParallaxMapping(vec2 texCoords, vec3 viewDir)
{
    // number of depth layers
    const float numLayers = 10;
    // calculate the size of each layer
    float layerDepth = 1.0 / numLayers;
    // depth of current layer
    float currentLayerDepth = 0.0;
    // the amount to shift the texture coordinates per layer (from vector P
    )
    vec2 P = viewDir.xy * height_scale;
    float deltaTexCoords = P / numLayers;
```

```
[...]  
}
```

Here we first set things up: we specify the number of layers, calculate the depth of each layer and finally calculate the texture coordinate offset that we have to shift along the direction of \vec{P} per layer.

We then iterate through all the layers, starting from the top, until we find a depthmap value less than the layer's depth value:

```
// get initial values  
vec2 currentTexCoords = texCoords;  
float currentDepthMapValue = texture(depthMap, currentTexCoords).r;  
  
while(currentLayerDepth < currentDepthMapValue)  
{  
    // shift texture coordinates along direction of P  
    currentTexCoords -= deltaTexCoords;  
    // get depthmap value at current texture coordinates  
    currentDepthMapValue = texture(depthMap, currentTexCoords).r;  
    // get depth of next layer  
    currentLayerDepth += layerDepth;  
}  
  
return texCoords - currentTexCoords;
```

Here we loop over each depth layer and stop until we find the texture coordinate offset along vector \vec{P} that first returns a depth that's below the (displaced) surface. The resulting offset is subtracted from the fragment's texture coordinates to get a final displaced texture coordinate vector, this time with much more accuracy compared to traditional parallax mapping.

With around 10 samples the brick surface already looks more viable even when looking at it from an angle, but steep parallax mapping really shines when having a complex surface with steep height changes like the earlier displayed wooden toy surface:

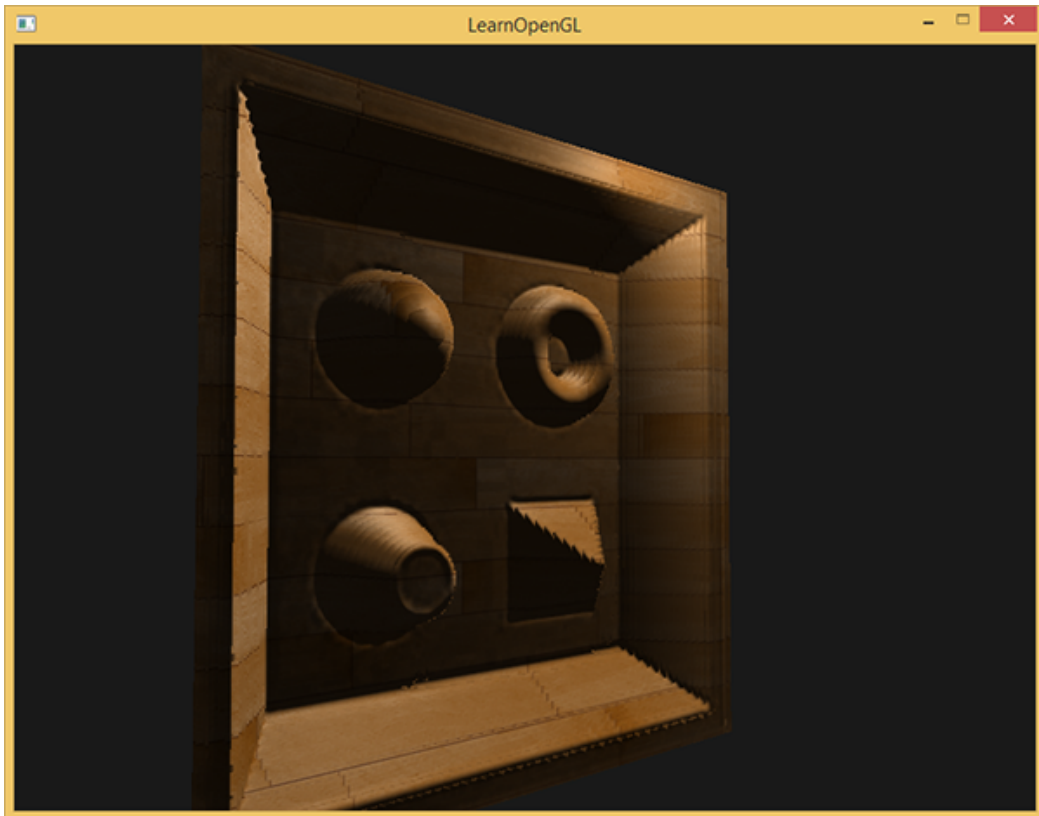

We can improve the algorithm a bit by exploiting one of Parallax Mapping's properties. When looking straight onto a surface there isn't much texture displacement going on while there is a lot of displacement when looking at a surface from an angle (visualize the view direction on both cases). By taking less samples when looking straight at a surface and more samples when looking at an angle we only sample the necessary amount:

```
const float minLayers = 8;
const float maxLayers = 32;
float numLayers = mix(maxLayers, minLayers, abs(dot(vec3(0.0, 0.0, 1.0),
viewDir)));
```

Here we take the dot product of `viewDir` and the positive z direction and use its result to align the number of samples more to `minLayers` or `maxLayers` based on the angle we're looking towards a surface (note that the positive z direction is equal to the surface's normal vector in tangent space). If we were to look at a direction parallel to the surface we'd use a total of 32 layers.

You can find the updated fragment shader code [here](#). You can also find the wooden toy box surface here: [diffuse](#), [normal](#) and [depth](#).

Steep Parallax Mapping also comes with its problems though. Because the technique is based on a finite number of samples we get aliasing effects and the clear distinctions between layers can easily be spotted:

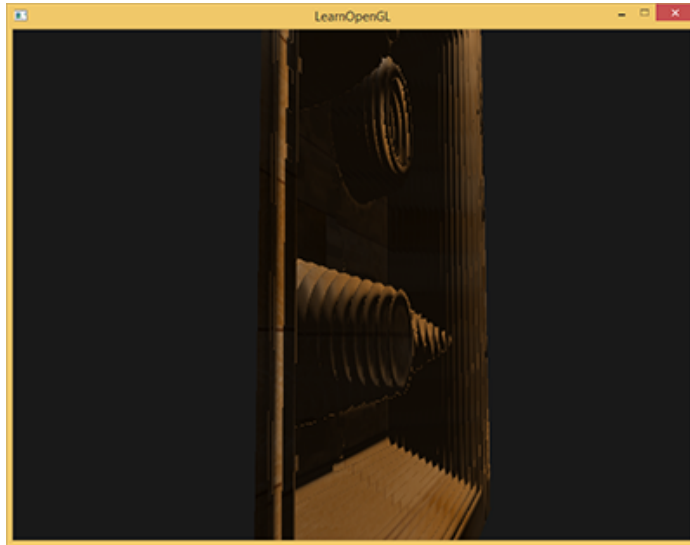

We can reduce the issue by taking a larger number of samples, but this quickly becomes too heavy a burden on performance. There are several approaches that aim to fix this issue by not taking the first position that's below the (displaced) surface, but by *interpolating* between the position's two closest depth layers to find a much closer match to B .

Two of the more popular of these approaches are called **Relief Parallax Mapping** and **Parallax Occlusion Mapping** of which Relief Parallax Mapping gives the most accurate results, but is also more performance heavy compared to Parallax Occlusion Mapping. Because Parallax Occlusion Mapping gives almost the same results as Relief Parallax Mapping and is also more efficient it is often the preferred approach and also the last type of Parallax Mapping we're going to discuss.

38.3 Parallax Occlusion Mapping

Parallax Occlusion Mapping is based on the same principles as Steep Parallax Mapping, but instead of taking the texture coordinates of the first depth layer after a collision, we're going to linearly interpolate between the depth layer after and before the collision. We base the weight of the linear interpolation on how far the surface's height is from the depth layer's value of both layers. Take a look at the following picture to get a grasp of how it works:

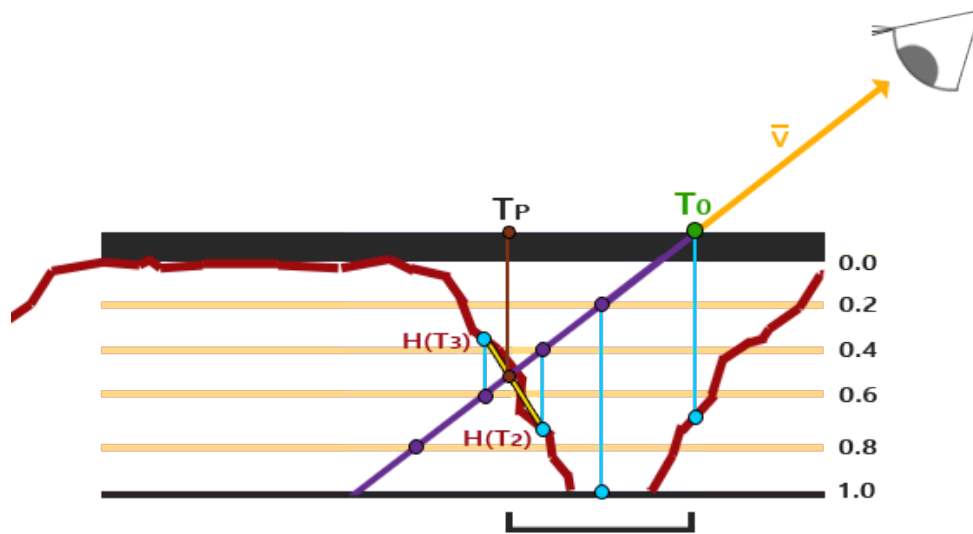

As you can see it's largely similar to Steep Parallax Mapping with as an extra step the linear interpolation between the two depth layers' texture coordinates surrounding the intersected point. This is again an approximation, but significantly more accurate than Steep Parallax Mapping.

The code for Parallax Occlusion Mapping is an extension on top of Steep Parallax Mapping and not too difficult:

```
[...] // steep parallax mapping code here

// get texture coordinates before collision (reverse operations)
vec2 prevTexCoords = currentTexCoords + deltaTexCoords;

// get depth after and before collision for linear interpolation
float afterDepth = currentDepthMapValue - currentLayerDepth;
float beforeDepth = texture(depthMap, prevTexCoords).r - currentLayerDepth
    + layerDepth;

// interpolation of texture coordinates
float weight = afterDepth / (afterDepth - beforeDepth);
vec2 finalTexCoords = prevTexCoords * weight + currentTexCoords * (1.0 -
    weight);

return finalTexCoords;
```

After we found the depth layer after intersecting the (displaced) surface geometry we also retrieve the texture coordinates of the depth layer before intersection. Next we calculate the distance of the (displaced) geometry's depth from the corresponding depth layers and interpolate between these two values. The linear interpolation is a basic interpolation between both layer's texture coordinates. The function then finally returns the final interpolated texture coordinates.

Parallax Occlusion Mapping gives surprisingly good results and although some slight artifacts and aliasing issues are still visible it's a generally a good trade-off and only really visible when heavily zoomed in or looking at very steep angles.

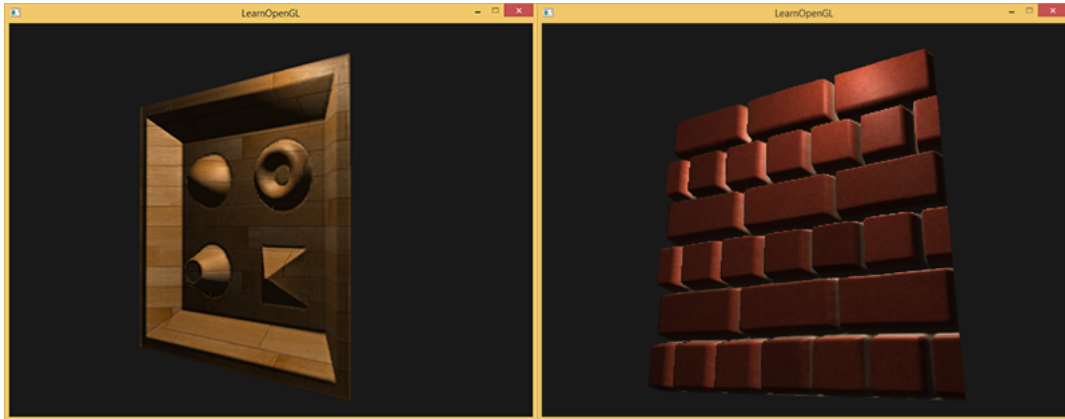

You can find the (same) source code [here](#) together with its [vertex](#) and (updated) [fragment](#) shader.

Parallax Mapping is a great technique to boost the detail of your scene, but does come with a few artifacts you'll have to consider when using it. Most often parallax mapping is used on floor or wall-like surfaces where it's not as easy to determine the surface's outline and the viewing angle is most often roughly perpendicular to the surface. This way the artifacts of Parallax Mapping aren't as noticeable and makes it an incredibly interesting technique for boosting your objects' details.

38.4 Additional resources

- [Parallax Occlusion Mapping in GLSL](#): great parallax mapping tutorial by sunandblackcat.com.
- [How Parallax Displacement Mapping Works](#): a nice video tutorial of how parallax mapping works by TheBennyBox.

39. HDR

Brightness and color values by default are clamped between 0.0 and 1.0 when stored into a framebuffer. This at first seemingly innocent statement caused us to always specify light and color values somewhere in this range trying to make them fit into the scene. This works oké and gives decent results, but what happens if we walk in a specifically bright area with multiple bright light sources that as a total sum exceed 1.0? The answer is that all fragments that have a brightness or color sum over 1.0 get clamped to 1.0 which isn't pretty to look at:

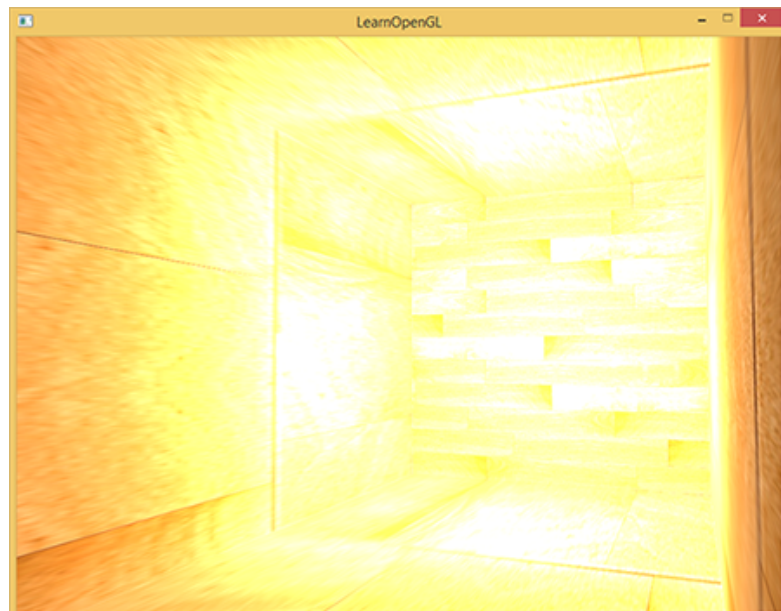

Due to a large number of fragments' color values getting clamped to 1.0 each of the bright fragments have the exact same white color in a large region, losing a significant amount of detail and giving it a fake look.

A solution to this problem would be to reduce the strength of the light sources and ensure no area of fragments in your scene ends up brighter than 1.0; this is not a good solution as this forces you to use unrealistic lighting parameters. A better approach is to allow color values to temporarily exceed 1.0 and transform them back to the original range of 0.0 and 1.0 as a final step, but without losing detail.

Monitors are limited to display colors in the range of 0.0 and 1.0, but there is no such limitation in lighting equations. By allowing fragment colors to exceed 1.0 we have a much higher range of color values available to work in known as **high dynamic range** (HDR). With high dynamic range bright things can be really bright, dark things can be really dark, and details can be seen in both.

High dynamic range was originally only used for photography where a photographer takes multiple pictures of the same scene with varying exposure levels, capturing a large range of color values. These combined images form a HDR image where a large range of details are visible based on the combined exposure levels or a specific exposure it is viewed with. For instance, the image below shows a lot of detail at brightly lit regions with a high exposure (look at the window), but these details are gone with a low exposure. However, a high exposure now reveals a great amount of detail at darker regions that weren't previously visible.



This is also very similar to how the human eye works and the basis of high dynamic range rendering. When there is little light the human eye adapts itself so the darker parts are much better visible and similarly for bright areas, it's like the human eye has an automatic exposure slider based on the scene's brightness.

High dynamic range rendering works a bit like that. We allow for a much larger range of color values to render to collecting a large range of dark and bright details of a scene, and at the end we transform all the HDR values back to the **low dynamic range** (LDR) of [0.0, 1.0]. This process of converting HDR values to LDR values is called **tone mapping** and a large collection of tone mapping algorithms exist that aim to preserve most HDR details during the conversion process. These tone mapping algorithms often involve an exposure parameter that selectively favors dark or bright regions.

When it comes to real-time rendering high dynamic range allows us not only to exceed the LDR range of [0.0, 1.0] and preserve more detail, but also gives us the ability to specify a light source's intensity by their *real* intensities. For instance, the sun has a much higher intensity than something like a flashlight so why not configure the sun as such (like a diffuse brightness of 10.0). This allows us to more properly configure a scene's lighting with more realistic lighting parameters, something that wouldn't be possible with LDR rendering as they'd then directly get clamped to 1.0.

As monitors only display colors in the range between 0.0 and 1.0 we do need to transform the

currently high dynamic range of color values back to the monitor's range. Simply re-transforming the colors back with a simple average still wouldn't do us too much good as brighter areas then become a lot more dominant. What we can do however, is use different equations and/or curves to transform the HDR values back to LDR that give us complete control over the scene's brightness. This is the process earlier denoted as tone mapping and the final step of HDR rendering.

39.1 Floating point framebuffers

To implement high dynamic range rendering we need some way to prevent color values getting clamped after each fragment shader run. When framebuffers use a normalized fixed-point color format (like `GL_RGB`) as their colorbuffer's internal format OpenGL automatically clamps the values between 0.0 and 1.0 before storing them in the framebuffer. This operation holds for most types of framebuffer formats, except for floating point formats that are used for their extended range of values.

When the internal format of a framebuffer's colorbuffer is specified as `GL_RGB16F`, `GL_RGBA16F`, `GL_RGB32F` or `GL_RGBA32F` the framebuffer is known as a **floating point framebuffer** that can store floating point values outside the default range of 0.0 and 1.0. This is perfect for rendering in high dynamic range!

To create a floating point framebuffer the only thing we need to change is its colorbuffer's internal format parameter:

```
glBindTexture(GL_TEXTURE_2D, colorBuffer);
glTexImage2D(GL_TEXTURE_2D, 0, GL_RGB16F, SCR_WIDTH, SCR_HEIGHT, 0, GL_RGB,
             GL_FLOAT, NULL);
```

The default framebuffer of OpenGL (by default) only takes up 8 bits per color component. With a floating point framebuffer with 32 bits per color component (when using `GL_RGB32F` or `GL_RGBA32F`) we're using 4 times more memory for storing color values. As 32 bits isn't really necessary unless you need a high level of precision using `GL_RGB16F` will suffice.

With a floating point colorbuffer attached to a framebuffer we can now render the scene into this framebuffer knowing color values won't get clamped between 0.0 and 1.0. In this tutorial's example demo we first render a lighted scene into the floating point framebuffer and then display the framebuffer's colorbuffer on a screen-filled quad; it'll look a bit like this:

```
glBindFramebuffer(GL_FRAMEBUFFER, hdrFBO);
glClear(GL_COLOR_BUFFER_BIT | GL_DEPTH_BUFFER_BIT);
// [...] Render (lighted) scene
glBindFramebuffer(GL_FRAMEBUFFER, 0);

// now render hdr colorbuffer to 2D screen-filling quad with different
// shader
hdrShader.Use();
glActiveTexture(GL_TEXTURE0);
glBindTexture(GL_TEXTURE_2D, hdrColorBufferTexture);
RenderQuad();
```

Here a scene's color values are filled into a floating point colorbuffer which can contain any arbitrary color value, possibly exceeding 1.0. For this tutorial a simple demo scene was created

with a large stretched cube acting as a tunnel with four point lights, one being extremely bright positioned at the tunnel's end:

```
std::vector<glm::vec3> lightColors;
lightColors.push_back(glm::vec3(200.0f, 200.0f, 200.0f));
lightColors.push_back(glm::vec3(0.1f, 0.0f, 0.0f));
lightColors.push_back(glm::vec3(0.0f, 0.0f, 0.2f));
lightColors.push_back(glm::vec3(0.0f, 0.1f, 0.0f));
```

Rendering into the floating point framebuffer is exactly the same as we would normally render into a framebuffer. What is new is `hdrShader`'s fragment shader that renders the final 2D quad with the floating point colorbuffer texture attached. Let's first define a simple pass-through fragment shader:

```
#version 330 core
out vec4 color;
in vec2 TexCoords;

uniform sampler2D hdrBuffer;

void main()
{
    vec3 hdrColor = texture(hdrBuffer, TexCoords).rgb;
    color = vec4(hdrColor, 1.0);
}
```

Here we directly sample the floating point colorbuffer and use its color value as the fragment shader's output. However, as the 2D quad's output is directly rendered into the default framebuffer, all the fragment shader's output values will be clamped between 0.0 and 1.0 even though we have several values in the floating point color texture exceeding 1.0.

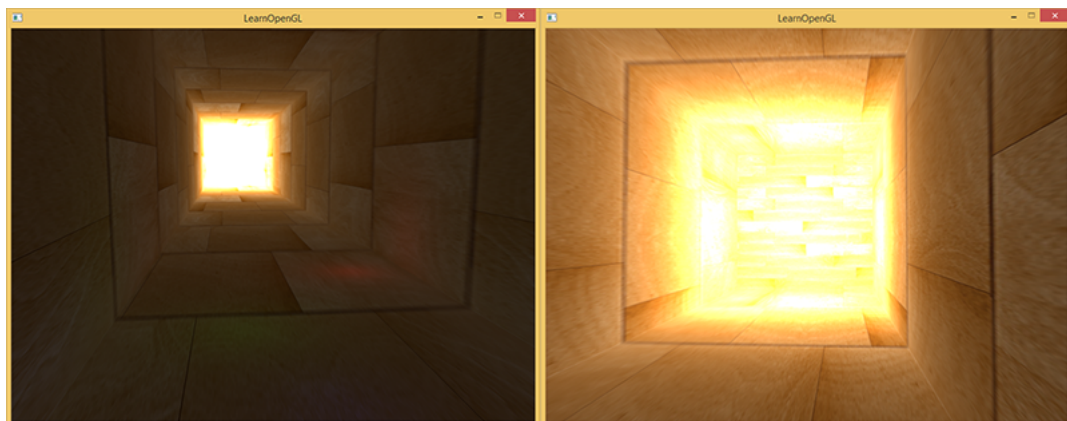

It becomes clear the intense light values at the end of the tunnel are clamped to 1.0 as a large portion of it is completely white, effectively losing all lighting details in the process that exceed 1.0. As we directly transform HDR values to LDR values it is as if we have no HDR enabled in the first place. What we need to do to fix this is to transform all the floating point color values back into the 0.0 - 1.0 range without losing any of its details. We need to apply a process called **tone mapping**.

39.2 Tone mapping

Tone mapping is the process of transforming floating point color values to the expected $[0.0, 1.0]$ range known as low dynamic range without losing too much detail, often accompanied with a specific stylistic color balance.

The simplest tone mapping algorithm is known as **Reinhard tone mapping** and involves dividing the entire HDR color values to LDR color values evenly balancing them all out. The Reinhard tone mapping algorithm evenly spreads out all brightness values onto LDR. We include Reinhard tone mapping into the previous fragment shader and also add a **gamma correction** filter for good measure (including the use of SRGB textures):

```
void main()
{
    const float gamma = 2.2;
    vec3 hdrColor = texture(hdrBuffer, TexCoords).rgb;

    // Reinhard tone mapping
    vec3 mapped = hdrColor / (hdrColor + vec3(1.0));
    // Gamma correction
    mapped = pow(mapped, vec3(1.0 / gamma));

    color = vec4(mapped, 1.0);
}
```

With Reinhard tone mapping applied we no longer lose any detail at the bright areas of our scene. It does tend to slightly favor brighter areas, making darker regions seem less detailed and distinct:

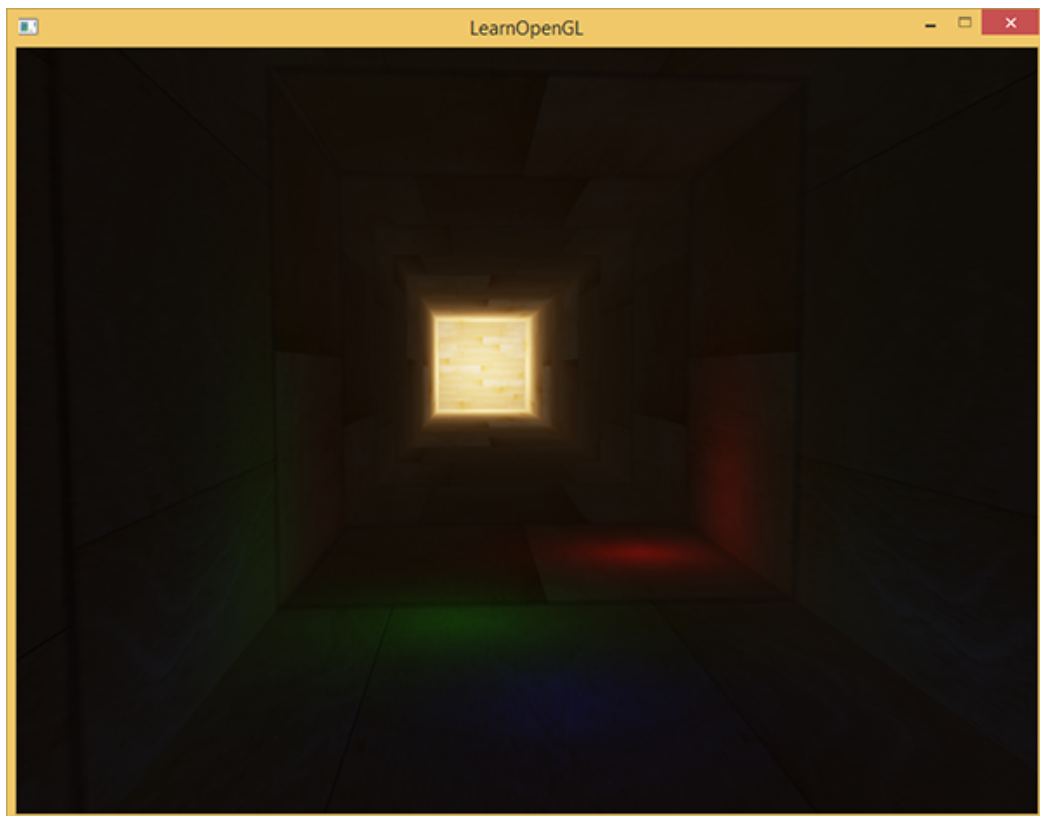

Here you can again see details at the end of the tunnel as the wood texture pattern becomes visible again. With this relatively simple tone mapping algorithm we can properly see the entire range of HDR values stored in the floating point framebuffer, giving us precise control over the scene's lighting without losing details.

Another interesting use of tone mapping is to allow the use of an exposure parameter. You probably remember from the introduction that HDR images contain a lot of details visible at different exposure levels. If we have a scene that features a day and night cycle it makes sense to use a lower exposure at daylight and a higher exposure at night time, similar to how the human eye adapts. With such an exposure parameter it allows us to configure lighting parameters that work both at day and night under different lighting conditions as we only have to change the exposure parameter.

A relatively simple exposure tone mapping algorithm looks as follows:

```
uniform float exposure;

void main()
{
    const float gamma = 2.2;
    vec3 hdrColor = texture(hdrBuffer, TexCoords).rgb;

    // Exposure tone mapping
    vec3 mapped = vec3(1.0) - exp(-hdrColor * exposure);
    // Gamma correction
    mapped = pow(mapped, vec3(1.0 / gamma));

    color = vec4(mapped, 1.0);
}
```

Here we defined an `exposure` uniform that defaults at `1.0` and allows us to more precisely specify whether we'd like to focus more on dark or bright regions of the HDR color values. For instance, with high exposure values the darker areas of the tunnel show significantly more detail. In contrast, a low exposure largely removes the dark region details, but allows us to see more detail in the bright areas of a scene. Take a look at the image below to see the tunnel at multiple exposure levels:

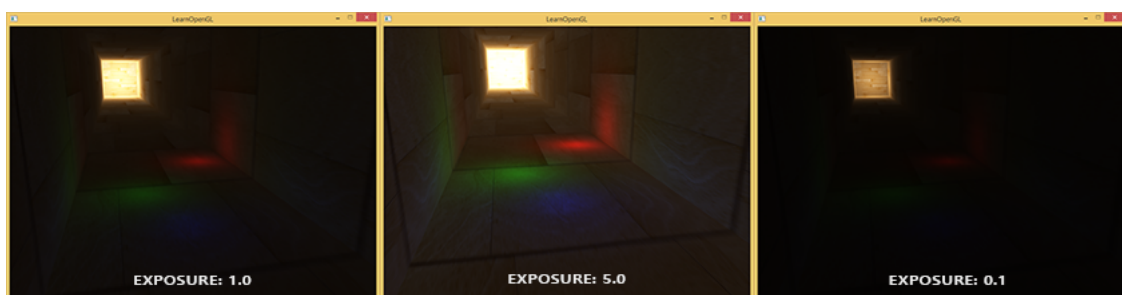

This image clearly shows the benefit of high dynamic range rendering. By changing the exposure level we get to see a lot of details of our scene, that would've been otherwise lost with low dynamic range rendering. Take the end of the tunnel for example, with a normal exposure the wood structure is barely visible, but with a low exposure the detailed wooden patterns are clearly visible. The same holds for the wooden patterns close by that are much better visible with a high exposure.

You can find the source code of the demo [here](#) together with the HDR's [vertex](#) and [fragment](#) shader.

39.2.1 More HDR

The two tone mapping algorithms shown are only a few of a large collection of (more advanced) tone mapping algorithms of which each has their own strengths and weaknesses. Some tone mapping algorithms favor certain colors/intensities above others and some algorithms display both the low and high exposure colors at the same time to create more colorful and detailed images. There is also a collection of techniques known as [automatic exposure adjustment](#) or [eye adaptation](#) techniques that determine the brightness of the scene in the previous frame and (slowly) adapt the exposure parameter such that the scene gets brighter in dark areas or darker in bright areas mimicking the human eye.

The real benefit of HDR rendering really shows itself in large and complex scenes with heavy lighting algorithms. As it is difficult to create such a complex demo scene for teaching purposes scene while keeping it accessible the tutorial's demo scene is small and lacks detail. While relatively simple it does show some of the benefits of HDR rendering: no details are lost in high and dark regions as they can be regained with tone mapping, the addition of multiple lights doesn't cause clamped regions and light values can be specified by their original brightness values not being limited by LDR values. Furthermore, HDR rendering also makes several interesting effects more feasible and realistic; one of these effects is [bloom](#) that we discuss in the next [next](#) tutorial.

39.3 Additional resources

- [Does HDR rendering have any benefits if bloom won't be applied?](#): a stackexchange question that features a great lengthy answer describing some of the benefits of HDR rendering.
- [What is tone mapping? How does it relate to HDR?](#): another interesting answer with great reference images to explain tone mapping.

40. Bloom

Bright light sources and brightly lit regions are often difficult to convey to the viewer as the intensity range of a monitor is limited. One way to distinguish bright light sources on a monitor is by making them glow, their light *bleeds* around the light source. This effectively gives the viewer the illusion these light sources or bright regions are intensely bright.

This light bleeding or glow effect is achieved with a post-processing effect called **bloom**. Bloom gives all brightly lit regions of a scene a glow-like effect. An example of a scene with and without glow can be seen below (image courtesy of Unreal):



Bloom gives noticeable visual cues about the brightness of objects as bloom tends to give the illusion objects are really bright. When done in a subtle fashion (which some games drastically fail to do) bloom significantly boosts the lighting of your scene and allows for a large range of dramatic effects.

Bloom works best in combination with **HDR** rendering. A common misconception is that HDR is the same as bloom as many people use the terms interchangeably. They are however completely different techniques used for different purposes. It is possible to implement bloom with default 8-bit precision framebuffers just as it is possible to use HDR without the bloom effect. It is simply that HDR makes bloom more effective to implement (as we'll later see).

To implement Bloom we render a lighted scene as usual and extract both the scene's HDR colorbuffer and an image of the scene with only its bright regions visible. The extracted brightness image is then blurred and the result added on top of the original HDR scene image.

Let's illustrate this process in a step by step fashion. We render a scene filled with 4 bright light sources visualized as colored cubes. The colored light cubes have a brightness values between 1.5 and 15.0. If we were to render this to an HDR colorbuffer the scene looks as follows:

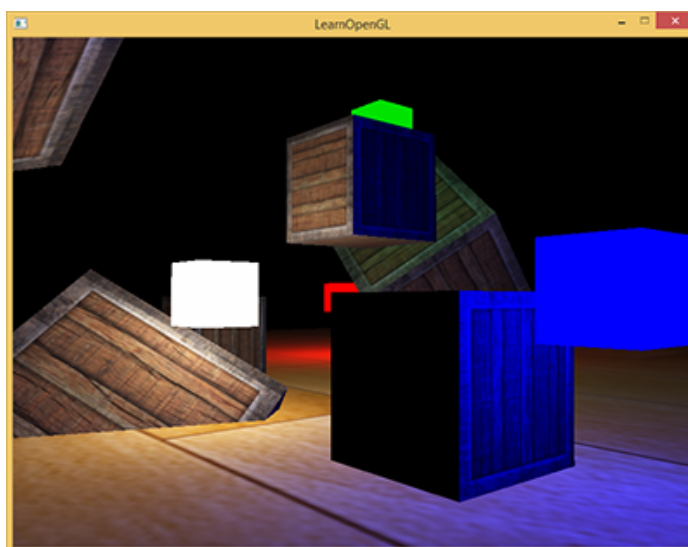

We take this HDR colorbuffer texture and extract all the fragments that exceed a certain brightness. This gives us an image that only shows the bright colored regions as their fragment intensities exceeded a certain threshold:

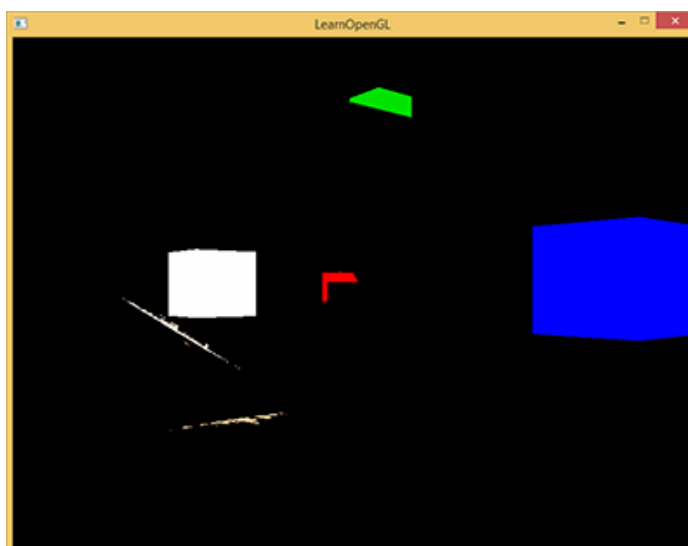

We then take this thresholded brightness texture and blur the result. The strength of the bloom effect is largely determined by the range and the strength of the blur filter used.



The resulting blurred texture is what we use to get the glow or light-bleeding effect. This blurred texture is added on top of the original HDR scene texture. Because the bright regions are extended in both width and height due to the blur filter the bright regions of the scene appear to glow or *bleed* light.

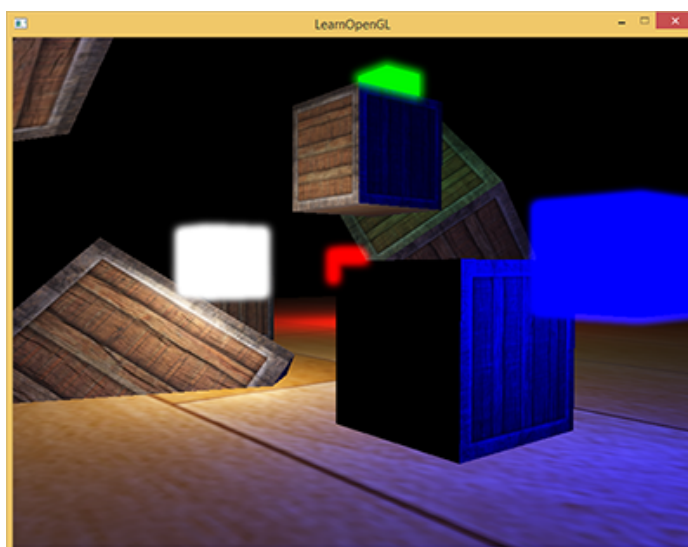

Bloom by itself isn't a complicated technique, but difficult to get exactly right. Most of its visual quality is determined by the quality and type of blur filter used for blurring the extracted brightness regions. Simply tweaking the blur filter can drastically change the quality of the bloom effect.

Following these steps give us the bloom post-processing effect. The image below briefly summarizes the required steps for implementing bloom.

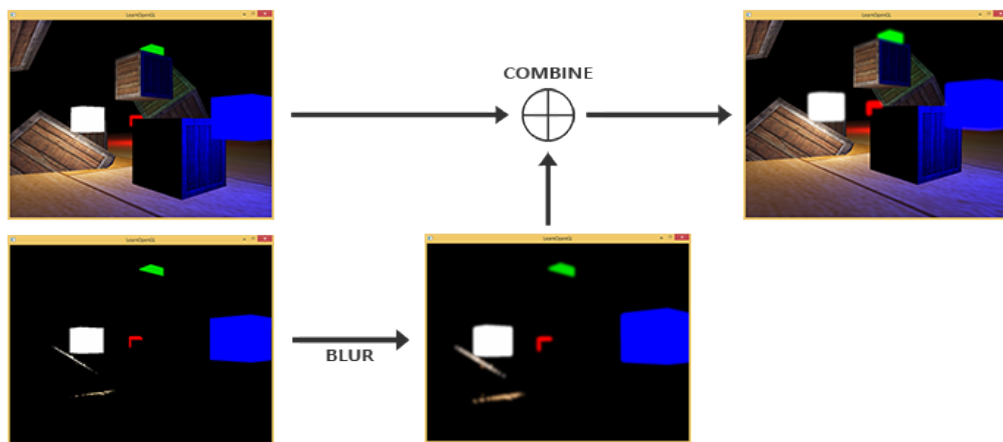

The first step requires us to extract all the bright colors of a scene based on some threshold. Let's first delve into that.

40.1 Extracting bright color

The first step requires us to extract two images from a rendered scene. We could render the scene twice, both rendering to a different framebuffer with different shaders, but we can also use a neat little trick called **Multiple Render Targets (MRT)** that allows us to specify more than one fragment shader output; this gives us the option to extract the first two images in a single render pass. By specifying a layout location specifier before a fragment shader's output we can control to which colorbuffer a fragment shader writes to:

```
layout (location = 0) out vec4 FragColor;
layout (location = 1) out vec4 BrightColor;
```

This only works however if we actually have multiple places to write to. As a requirement for using multiple fragment shader outputs we need multiple colorbuffers attached to the currently bound framebuffer object. You might remember from the [framebuffers](#) tutorial that we can specify a **color attachment** when linking a texture as a framebuffer's colorbuffer. Up until now we've always used `GL_COLOR_ATTACHMENT0`, but by also using `GL_COLOR_ATTACHMENT1` we can have two colorbuffers attached to a framebuffer object:

```
// Set up floating point framebuffer to render scene to
GLuint hdrFBO;
glGenFramebuffers(1, &hdrFBO);
glBindFramebuffer(GL_FRAMEBUFFER, hdrFBO);
GLuint colorBuffers[2];
glGenTextures(2, colorBuffers);
for (GLuint i = 0; i < 2; i++)
{
    glBindTexture(GL_TEXTURE_2D, colorBuffers[i]);
    glTexImage2D(
        GL_TEXTURE_2D, 0, GL_RGB16F, SCR_WIDTH, SCR_HEIGHT, 0, GL_RGB,
        GL_FLOAT, NULL
    );
    glTexParameteri(GL_TEXTURE_2D, GL_TEXTURE_MIN_FILTER, GL_LINEAR);
    glTexParameteri(GL_TEXTURE_2D, GL_TEXTURE_MAG_FILTER, GL_LINEAR);
    glTexParameteri(GL_TEXTURE_2D, GL_TEXTURE_WRAP_S, GL_CLAMP_TO_EDGE);
    glTexParameteri(GL_TEXTURE_2D, GL_TEXTURE_WRAP_T, GL_CLAMP_TO_EDGE);
}
```



```
// attach texture to framebuffer
glFramebufferTexture2D(
    GL_FRAMEBUFFER, GL_COLOR_ATTACHMENT0 + i, GL_TEXTURE_2D,
    colorBuffers[i], 0
);
}
```

We do have to explicitly tell OpenGL we're rendering to multiple colorbuffers via `glDrawBuffers` as otherwise OpenGL only renders to a framebuffer's first color attachment ignoring all others. We can do this by passing an array of color attachment enums that we'd like to render to in subsequent operations:

```
GLuint attachments[2] = { GL_COLOR_ATTACHMENT0, GL_COLOR_ATTACHMENT1 };
glDrawBuffers(2, attachments);
```

When rendering into this framebuffer, whenever a fragment shader uses the layout location specifier the respective colorbuffer is used to render the fragments to. This is great as this saves us an extra render pass for extracting bright regions as we can now directly extract them from the to-be-rendered fragment:

```
#version 330 core
layout (location = 0) out vec4 FragColor;
layout (location = 1) out vec4 BrightColor;

[...]

void main()
{
    [...] // first do normal lighting calculations and output results
    FragColor = vec4(lightning, 1.0f);
    // Check whether fragment output is higher than threshold, if so output
    // as brightness color
    float brightness = dot(FragColor.rgb, vec3(0.2126, 0.7152, 0.0722));
    if(brightness > 1.0)
        BrightColor = vec4(FragColor.rgb, 1.0);
}
```

Here we first calculate lighting as normal and pass it to the first fragment shader's output variable `FragColor`. Then we use what is currently stored in `FragColor` to determine if its brightness exceeds a certain threshold. We calculate the brightness of a fragment by properly transforming it to grayscale first (by taking the dot product of both vectors we effectively multiply each individual component of both vectors and add the results together) and if it exceeds a certain threshold, we output the color to the second colorbuffer that holds all bright regions; similarly for rendering the light cubes.

This also shows why bloom works incredibly well with HDR rendering. Because we render in high dynamic range, color values can exceed 1.0 which allows us to specify a brightness threshold outside the default range, giving us much more control over what of an image is considered as bright. Without HDR we'd have to set the threshold lower than 1.0 which is still possible, but regions are much quicker considered as bright which sometimes leads to the glow effect becoming too dominant (think of white glowing snow for example).

Within the two colorbuffers we then have an image of the scene as normal, and an image of the extracted bright regions; all obtained in a single render pass.

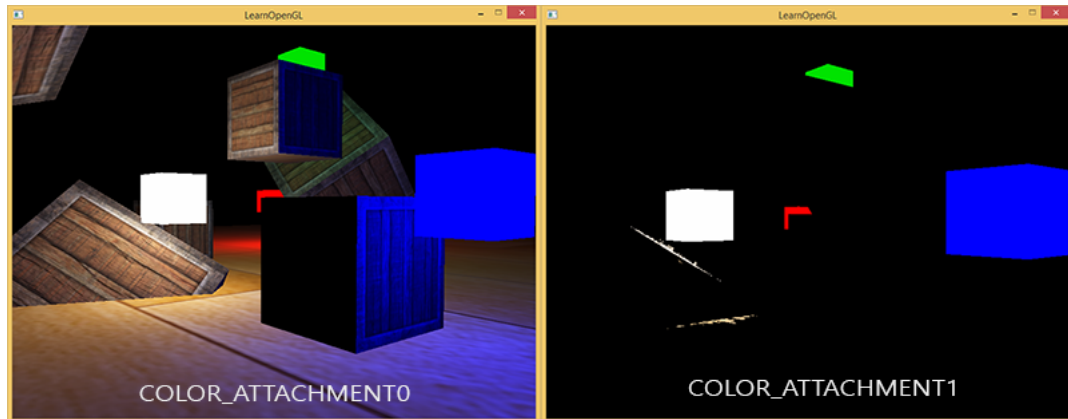

With an image of the extracted bright regions we now need to blur the image. We can do this with a simple box filter as we've done in the post-processing section of the framebuffer tutorial, but we'd rather use a more advanced and better-looking blur filter called **Gaussian blur**.

40.2 Gaussian blur

In the post-processing blur we simply took the average of all surrounding pixels of an image and while it does give us an easy blur it doesn't give the best results. A Gaussian blur is based on the Gaussian curve which is commonly described as a *bell-shaped curve* giving high values close to its center that gradually wear off over distance. The Gaussian curve can be mathematically represented in different forms, but generally has the following shape:

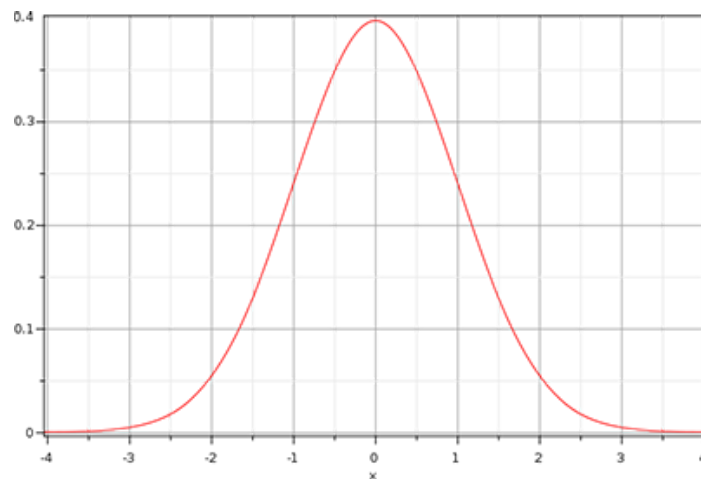

As the Gaussian curve has a larger area close to its center, using its values as weights to blur an image gives great results as samples close by have a higher precedence. If we for instance sample a 32x32 box around a fragment we use progressively smaller weights the larger the distance to the fragment; this generally gives a better and more realistic blur which is known as a **Gaussian blur**.

To implement a Gaussian blur filter we'd need a two-dimensional box of weights that we can obtain from a 2 dimensional Gaussian curve equation. The problem with this approach however is that it quickly becomes extremely heavy on performance. Take a blur kernel of 32 by 32 for example, this would require us to sample a texture a total of 1024 times for each fragment!

Luckily for us, the Gaussian equation has a very neat property that allows us to separate the

two dimensional equation into two smaller equations: one that describes the horizontal weights and the other that describes the vertical weights. We'd then first do a horizontal blur with the horizontal weights on an entire texture and then on the resulting texture do a vertical blur. Due to this property the results are exactly the same, but save us an incredible amount of performance as we'd now only have to do 32 + 32 samples compared to 1024! This is known as **two-pass Gaussian blur**.

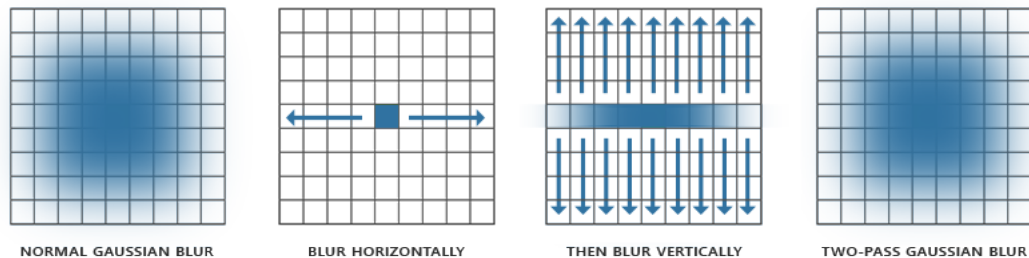

This does mean we need to blur an image at least two times and this works best with again the use of framebuffer objects. Specifically for implementing a Gaussian blur we're going to implement *ping-pong* framebuffers. That is a pair of framebuffers where we render a given number of times the other framebuffer's colorbuffer into the current framebuffer's colorbuffer with some alternating shader effect. We basically continuously switch the framebuffer to draw in and also the texture to draw with. This allows us to first blur the scene's texture in the first framebuffer, then blur the first framebuffer's colorbuffer into the second framebuffer and then the second framebuffer's colorbuffer into the first and so on.

Before we delve into the framebuffers let's first discuss the Gaussian blur's fragment shader:

```
#version 330 core
out vec4 FragColor;
in vec2 TexCoords;

uniform sampler2D image;

uniform bool horizontal;

uniform float weight[5] = float[] (0.227027, 0.1945946, 0.1216216,
    0.054054, 0.016216);

void main()
{
    vec2 tex_offset = 1.0 / textureSize(image, 0); // gets size of single
    texel
    vec3 result = texture(image, TexCoords).rgb * weight[0]; // current
    fragment's contribution
    if(horizontal)
    {
        for(int i = 1; i < 5; ++i)
        {
            result += texture(image, TexCoords + vec2(tex_offset.x * i,
            0.0)).rgb * weight[i];
            result += texture(image, TexCoords - vec2(tex_offset.x * i,
            0.0)).rgb * weight[i];
        }
    }
    else
    {
        for(int i = 1; i < 5; ++i)
        {
```

```

        result += texture(image, TexCoords + vec2(0.0, tex_offset.y * i
    )) .rgb * weight[i];
        result += texture(image, TexCoords - vec2(0.0, tex_offset.y * i
    )) .rgb * weight[i];
    }
}
FragColor = vec4(result, 1.0);
}

```

Here we take a relatively small sample of Gaussian weights that we each use to assign a specific weight to the horizontal or vertical samples around the current fragment. You can see that we basically split the blur filter into a horizontal and vertical section based on whatever value we set the `horizontal` uniform. We based the offset distance on the exact size of a texel obtained by the division of `1.0` over the size of the texture (obtained as a `vec2` from `textureSize`).

For blurring an image we create two basic framebuffer, each with only a colorbuffer texture:

```

GLuint pingpongFBO[2];
GLuint pingpongBuffer[2];
glGenFramebuffers(2, pingpongFBO);
glGenTextures(2, pingpongColorbuffers);
for (GLuint i = 0; i < 2; i++)
{
    glBindFramebuffer(GL_FRAMEBUFFER, pingpongFBO[i]);
    glBindTexture(GL_TEXTURE_2D, pingpongBuffer[i]);
    glTexImage2D(
        GL_TEXTURE_2D, 0, GL_RGB16F, SCR_WIDTH, SCR_HEIGHT, 0, GL_RGB,
        GL_FLOAT, NULL
    );
    glTexParameteri(GL_TEXTURE_2D, GL_TEXTURE_MIN_FILTER, GL_LINEAR);
    glTexParameteri(GL_TEXTURE_2D, GL_TEXTURE_MAG_FILTER, GL_LINEAR);
    glTexParameteri(GL_TEXTURE_2D, GL_TEXTURE_WRAP_S, GL_CLAMP_TO_EDGE);
    glTexParameteri(GL_TEXTURE_2D, GL_TEXTURE_WRAP_T, GL_CLAMP_TO_EDGE);
    glFramebufferTexture2D(
        GL_FRAMEBUFFER, GL_COLOR_ATTACHMENT0, GL_TEXTURE_2D, pingpongBuffer
        [i], 0
    );
}

```

Then after we've obtained an HDR texture and an extracted brightness texture we first fill one of the ping-pong framebuffers with the brightness texture and then blur the image 10 times (5 times horizontally and 5 times vertically):

```

GLboolean horizontal = true, first_iteration = true;
GLuint amount = 10;
shaderBlur.Use();
for (GLuint i = 0; i < amount; i++)
{
    glBindFramebuffer(GL_FRAMEBUFFER, pingpongFBO[horizontal]);
    glUniform1i(glGetUniformLocation(shaderBlur.Program, "horizontal"),
horizontal);
    glBindTexture(
        GL_TEXTURE_2D, first_iteration ? colorBuffers[1] : pingpongBuffers
        [!horizontal]
    );
    RenderQuad();
    horizontal = !horizontal;
}

```

```
if (first_iteration)
    first_iteration = false;
}
glBindFramebuffer(GL_FRAMEBUFFER, 0);
```

Each iteration we bind one of the two framebuffers based on whether we want to blur horizontally or vertically and bind the other framebuffer's colorbuffer as the texture to blur. The first iteration we specifically bind the texture we'd like to blur (`brightnessTexture`) as both colorbuffers would else end up empty. By repeating this process 10 times the brightness image ends up with a complete Gaussian blur that was repeated 5 times. This construct allows us to blur any image as often as we'd like; the more Gaussian blur iterations, the stronger the blur.

By blurring the extracted brightness texture 5 times we get a properly blurred image of all bright regions of a scene.

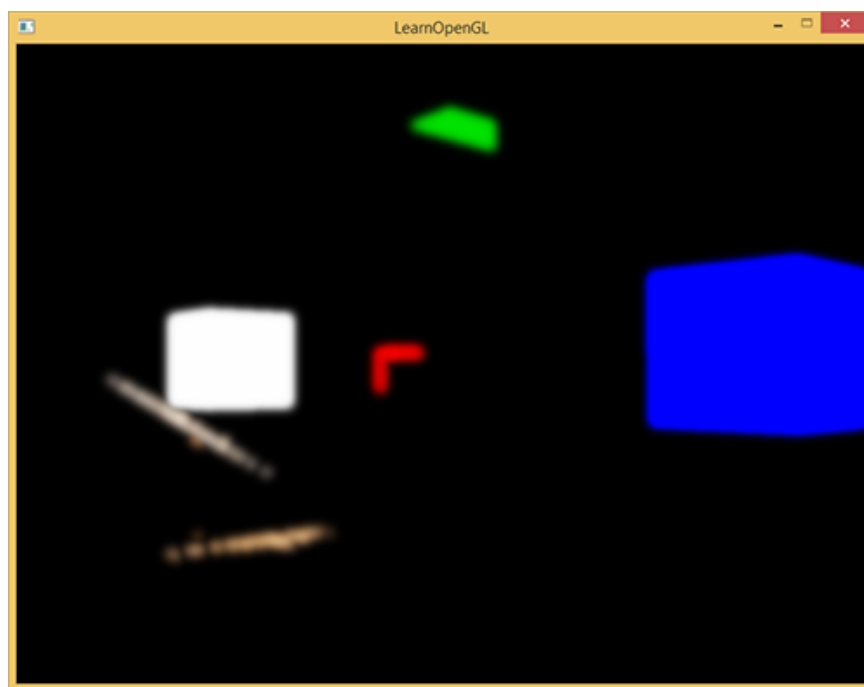

The last step to complete the bloom effect is to combine this blurred brightness texture with the original scene's HDR texture.

40.3 Blending both textures

With the scene's HDR texture and a blurred brightness texture of the scene we only need to combine the two to achieve the infamous bloom or glow effect. In the final fragment shader (largely similar to the one we used in the [HDR](#) tutorial) we additively blend both textures:

```
#version 330 core
out vec4 FragColor;
in vec2 TexCoords;

uniform sampler2D scene;
uniform sampler2D bloomBlur;
uniform float exposure;
```

```
void main()
{
    const float gamma = 2.2;
    vec3 hdrColor = texture(scene, TexCoords).rgb;
    vec3 bloomColor = texture(bloomBlur, TexCoords).rgb;
    hdrColor += bloomColor; // additive blending
    // tone mapping
    vec3 result = vec3(1.0) - exp(-hdrColor * exposure);
    // also gamma correct while we're at it
    result = pow(result, vec3(1.0 / gamma));
    FragColor = vec4(result, 1.0f);
}
```

Interesting to note here is that we add the bloom effect before we apply tone mapping. This way the added brightness of bloom is also softly transformed to LDR range with better relative lighting as a result.

With both textures added together all bright areas of our scene now get a proper glow effect:

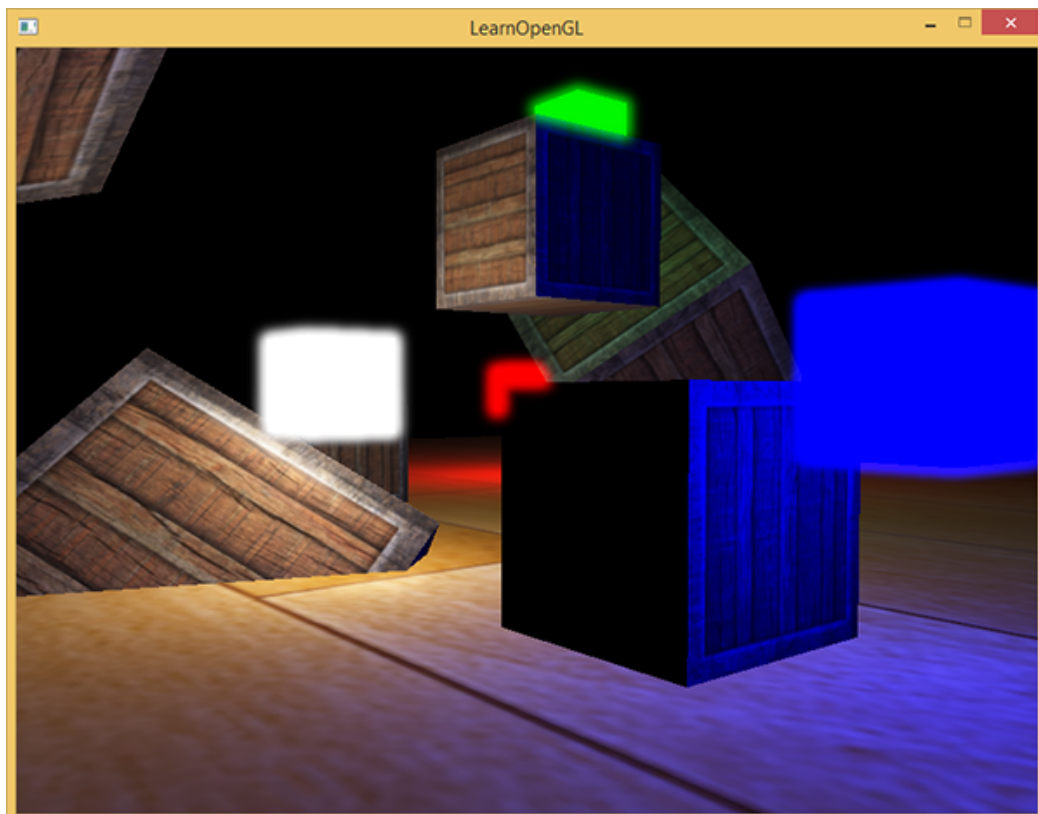

The colored cubes now appear much more bright and give a better illusion as light emitting objects. This is a relatively simple scene so the bloom effect isn't too impressive here, but in well lit scenes it can make a significant difference when properly configured. You can find the source code of this simple demo [here](#) together with the blur's [vertex](#) and [fragment](#) shader, the light cube's [fragment](#) shader, and the post-processing [vertex](#) and [fragment](#) shader.

For this tutorial we used a relatively simple Gaussian blur filter where we only take 5 samples in each direction. By taking more samples along a larger radius or repeating the blur filter an extra number of times we can improve the blur effect. As the quality of the blur directly correlates to the

quality of the bloom effect improving the blur step can make a significant improvement. Some of these improvements combine blur filters with varying sized blur kernels or use multiple Gaussian curves to selectively combine weights. The additional resources from Kalogirou and EpicGames below discuss how to significantly improve the bloom effect by improving the Gaussian blur.

40.4 Additional resources

- [Efficient Gaussian Blur with linear sampling](#): describes the Gaussian blur very well and how to improve its performance using OpenGL's bilinear texture sampling.
- [Bloom Post Process Effect](#): article from Epic Games about improving the bloom effect by combining multiple Gaussian curves for its weights.
- [How to do good bloom for HDR rendering](#): Article from Kalogirou that describes how to improve the bloom effect using a better Gaussian blur method.

A futuristic cityscape with a flying vehicle. The scene is rendered with a high level of detail, showing a dense collection of tall, slender buildings. A flying vehicle with blue lights is in the foreground, flying towards the left. The sky is a mix of blue and grey, suggesting a hazy or overcast day. The overall aesthetic is sci-fi and high-tech.

41. Deferred Shading

The way we did lighting so far was called **forward rendering** or **forward shading**, a straightforward approach where we render an object, light it according to all light sources in a scene and then render the next object, and so on for each object in the scene. While quite easy to understand and implement it is also quite heavy on performance as each rendered object has to iterate over each light source for every rendered fragment which is a lot! Forward rendering also tends to waste a lot of fragment shader runs in scenes with a high depth complexity (multiple objects cover the same screen pixel) as most fragment shader outputs are overwritten.

Deferred shading or **deferred rendering** tries to overcome these issues which drastically changes the way we render objects. This gives us several new options to significantly optimize scenes with large numbers of lights, allowing us to render hundreds or even thousands of lights with an acceptable framerate. Below is an image of a scene with 1847 point lights rendered with deferred shading (image courtesy of Hannes Nevalainen); something that wouldn't be possible with forward rendering.

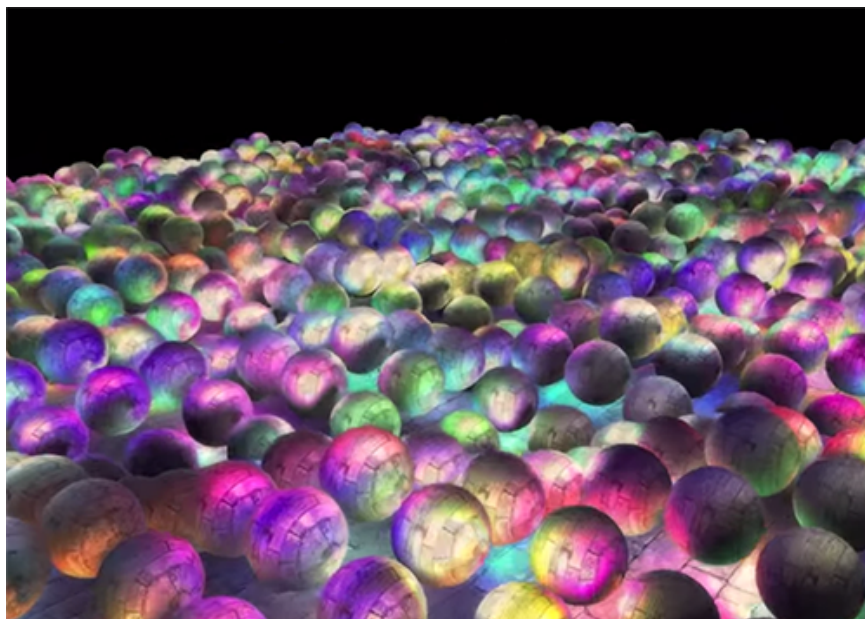

Deferred shading is based on the idea that we *defer* or *postpone* most of the heavy rendering (like lighting) to a later stage. Deferred shading consists of two passes: in the first pass called the **geometry pass** we render the scene once and retrieve all kinds of geometrical information from the objects that we store in a collection of textures called the **G-buffer**; think of position vectors, color vectors, normal vectors and/or specular values. The geometric information of a scene stored in the **G-buffer** is then later used for (more complex) lighting calculations. Below is the content of a G-buffer of a single frame:

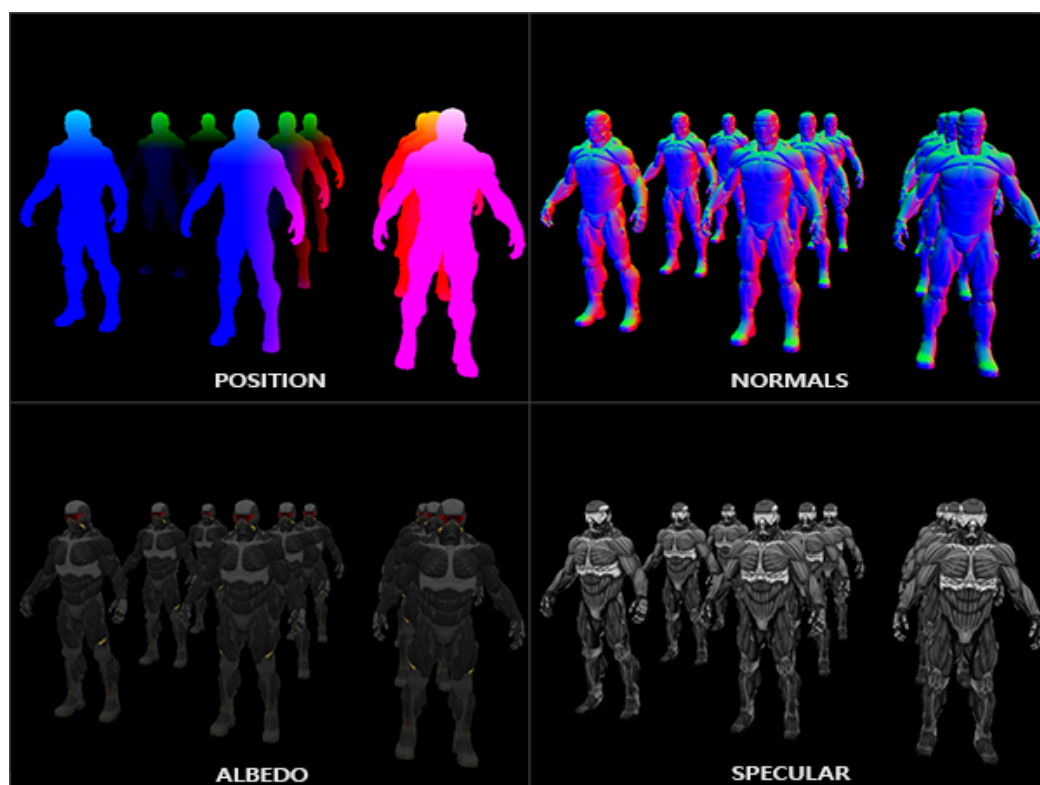

We use the textures from the G-buffer in a second pass called the **lighting pass** where we render a screen-filled quad and calculate the scene's lighting for each fragment using the geometrical

information stored in the G-buffer; pixel by pixel we iterate over the G-buffer. Instead of taking each object all the way from the vertex shader to the fragment shader we decouple its advanced fragment processes to a later stage. The lighting calculations remain exactly the same to what we're used to, but this time we take all required input variables from the corresponding G-buffer textures instead of the vertex shader (plus some uniform variables).

The image below nicely illustrates the total process of deferred shading.

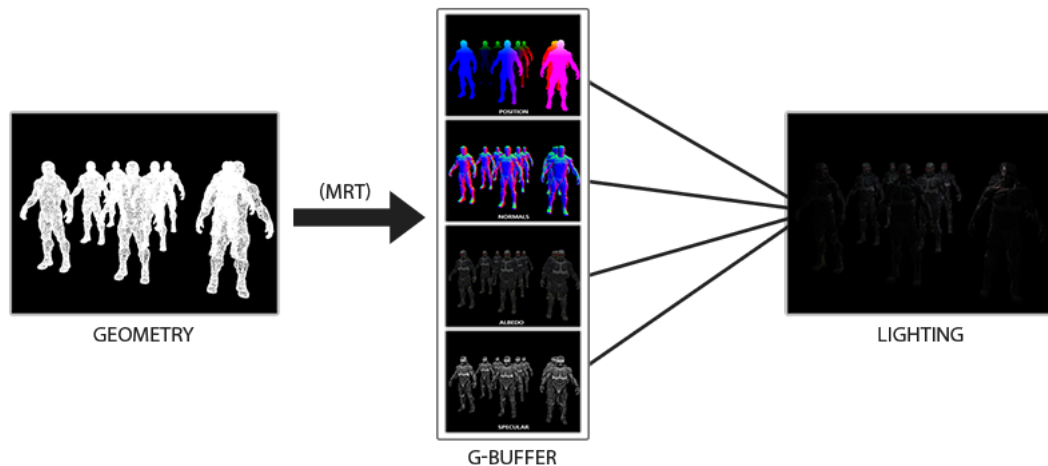

A major advantage of this approach is that whatever fragment ends up in the G-buffer is the actual fragment information that ends up as a screen pixel, as the depth test already concluded this fragment information as the top-most fragment. This ensures that for each pixel we process in the lighting pass we only do this once; saving us from a lot of unused render calls. Furthermore, deferred rendering opens up the possibility for further optimizations that allow us to render a much larger amount of light sources than we'd be able to use with forward rendering.

It also comes with a few disadvantages as the G-buffer requires us to store a relatively large amount of scene data in its texture colorbuffers which eats memory, especially since scene data like position vectors require a high precision. Another disadvantage is that it doesn't support blending (as we only have information of the topmost fragment) and MSAA no longer works. There are several workarounds for these disadvantages that we'll get to at the end of the tutorial.

Filling the G-buffer in the geometry pass is quite efficient as we directly store object information like position, color or normals into a framebuffer with a small or zero amount of processing. By also using [multiple render targets \(MRT\)](#) we can even do all this in a single render pass.

41.1 The G-buffer

The [G-buffer](#) is the collective term of all textures used to store lighting-relevant data for the final lighting pass. Let's take this moment to briefly review all the data we need to light a fragment with forward rendering:

- A 3D **position** vector to calculate the (interpolated) fragment position variable used for `lightDir` and `viewDir`.
- An RGB diffuse **color** vector also known as [albedo](#).
- A 3D **normal** vector for determining a surface's slope.

- A **specular intensity** float.
- All light source position and color vectors.
- The player or viewer's position vector.

With these (per-fragment) variables at our disposal we are able to calculate the (Blinn-)Phong lighting we're accustomed to. The light source positions and colors, and the player's view position can be configured using uniform variables, but the other variables are all specific to each of an object's fragments. If we can somehow pass the exact same data to the final deferred lighting pass we can calculate the same lighting effects, even though we're rendering fragments of a 2D quad.

There is no limit in OpenGL to what we can store in a texture so it makes sense to store all per-fragment data in one or multiple screen-filled textures called the G-buffer and use these later in the lighting pass. As the G-buffer textures will have the same size as the lighting pass's 2D quad we get the exact same fragment data we'd had in a forward rendering setting, but this time in the lighting pass; there is a one on one mapping.

In pseudocode the entire process will look a bit like this:

```
while(...) // game loop
{
    // 1. Geometry pass: render all geometric/color data to g-buffer
    glBindFramebuffer(GL_FRAMEBUFFER, gBuffer);
    glClear(GL_COLOR_BUFFER_BIT | GL_DEPTH_BUFFER_BIT);
    gBufferShader.Use();
    for(Object obj : Objects)
    {
        ConfigureShaderTransformsAndUniforms();
        obj.Draw();
    }
    // 2. Lighting pass: use g-buffer to calculate the scene's lighting
    glBindFramebuffer(GL_FRAMEBUFFER, 0);
    glClear(GL_COLOR_BUFFER_BIT);
    lightingPassShader.Use();
    BindAllGBufferTextures();
    SetLightingUniforms();
    RenderQuad();
}
```

The data we'll need to store of each fragment is a **position** vector, a **normal** vector, a **color** vector and a **specular intensity** value. In the geometry pass we thus need to render all objects of the scene and store these data components in the G-buffer. We can again use [multiple render targets](#) to render to multiple colorbuffers in a single render pass; this was briefly discussed in the [bloom](#) tutorial.

For the geometry pass we'll need to initialize a framebuffer object that we'll intuitively call `gBuffer` that has multiple colorbuffers attached and a single depth renderbuffer object. For the position and normal texture we'd preferably use a high-precision texture (16 or 32-bit float per component) and albedo and specular values we'll be fine with a default texture (8-bit precision per component).

```
GLuint gBuffer;
glGenFramebuffers(1, &gBuffer);
glBindFramebuffer(GL_FRAMEBUFFER, gBuffer);
GLuint gPosition, gNormal, gColorSpec;
```

```

// - Position color buffer
glGenTextures(1, &gPosition);
glBindTexture(GL_TEXTURE_2D, gPosition);
glTexImage2D(GL_TEXTURE_2D, 0, GL_RGB16F, SCR_WIDTH, SCR_HEIGHT, 0, GL_RGB,
             GL_FLOAT, NULL);
glTexParameteri(GL_TEXTURE_2D, GL_TEXTURE_MIN_FILTER, GL_NEAREST);
glTexParameteri(GL_TEXTURE_2D, GL_TEXTURE_MAG_FILTER, GL_NEAREST);
glFramebufferTexture2D(GL_FRAMEBUFFER, GL_COLOR_ATTACHMENT0, GL_TEXTURE_2D,
                      gPosition, 0);

// - Normal color buffer
glGenTextures(1, &gNormal);
glBindTexture(GL_TEXTURE_2D, gNormal);
glTexImage2D(GL_TEXTURE_2D, 0, GL_RGB16F, SCR_WIDTH, SCR_HEIGHT, 0, GL_RGB,
             GL_FLOAT, NULL);
glTexParameteri(GL_TEXTURE_2D, GL_TEXTURE_MIN_FILTER, GL_NEAREST);
glTexParameteri(GL_TEXTURE_2D, GL_TEXTURE_MAG_FILTER, GL_NEAREST);
glFramebufferTexture2D(GL_FRAMEBUFFER, GL_COLOR_ATTACHMENT1, GL_TEXTURE_2D,
                      gNormal, 0);

// - Color + Specular color buffer
glGenTextures(1, &gAlbedoSpec);
glBindTexture(GL_TEXTURE_2D, gAlbedoSpec);
glTexImage2D(GL_TEXTURE_2D, 0, GL_RGBA, SCR_WIDTH, SCR_HEIGHT, 0, GL_RGBA,
             GL_FLOAT, NULL);
glTexParameteri(GL_TEXTURE_2D, GL_TEXTURE_MIN_FILTER, GL_NEAREST);
glTexParameteri(GL_TEXTURE_2D, GL_TEXTURE_MAG_FILTER, GL_NEAREST);
glFramebufferTexture2D(GL_FRAMEBUFFER, GL_COLOR_ATTACHMENT2, GL_TEXTURE_2D,
                      gAlbedoSpec, 0);

// - Tell OpenGL which color attachments we'll use (of this framebuffer)
//   for rendering
GLuint attachments[3] = { GL_COLOR_ATTACHMENT0, GL_COLOR_ATTACHMENT1,
                          GL_COLOR_ATTACHMENT2 };
glDrawBuffers(3, attachments);

// Then also add render buffer object as depth buffer and check for
// completeness.
[...]
```

Since we use multiple render targets we have to explicitly tell OpenGL which of the colorbuffers associated with `GBuffer` we'd like to render to with `glDrawBuffers`. Also interesting to note here is that we store position and normal data in an RGB texture as we have 3 components each, but we store color and specular intensity data combined in a single RGBA texture; this saves us from having to declare an additional colorbuffer texture. As your deferred shading pipeline gets more complex and needs more data you'll quickly find new ways to combine data in individual textures.

Next we need to render into the G-buffer. Assuming each object has a diffuse, a normal and a specular intensity texture we'd use something like the following fragment shader to render into the G-buffer:

```

#version 330 core
layout (location = 0) out vec3 gPosition;
layout (location = 1) out vec3 gNormal;
layout (location = 2) out vec4 gAlbedoSpec;

in vec2 TexCoords;
```

```
in vec3 FragPos;
in vec3 Normal;

uniform sampler2D texture_diffuse1;
uniform sampler2D texture_specular1;

void main()
{
    // Store the fragment position vector in the first gbuffer texture
    gPosition = FragPos;
    // Also store the per-fragment normals into the gbuffer
    gNormal = normalize(Normal);
    // And the diffuse per-fragment color
    gAlbedoSpec.rgb = texture(texture_diffuse1, TexCoords).rgb;
    // Store specular intensity in gAlbedoSpec's alpha component
    gAlbedoSpec.a = texture(texture_specular1, TexCoords).r;
}
```

As we use multiple render targets, the layout specifier tells OpenGL to which colorbuffer of the currently active framebuffer we render to. Note that we do not store the specular intensity into a single colorbuffer texture as we can store its single float value in the alpha component of one of the other colorbuffer textures.

Keep in mind that with lighting calculations it is extremely important to keep all variables in the same coordinate space; in this case we store (and calculate) all variables in world-space.

If we'd now were to render a large collection of nanosuit objects into the `gBuffer` framebuffer and visualize its content by projecting its colorbuffers one by one onto a screen-filled quad we'd see something like this:

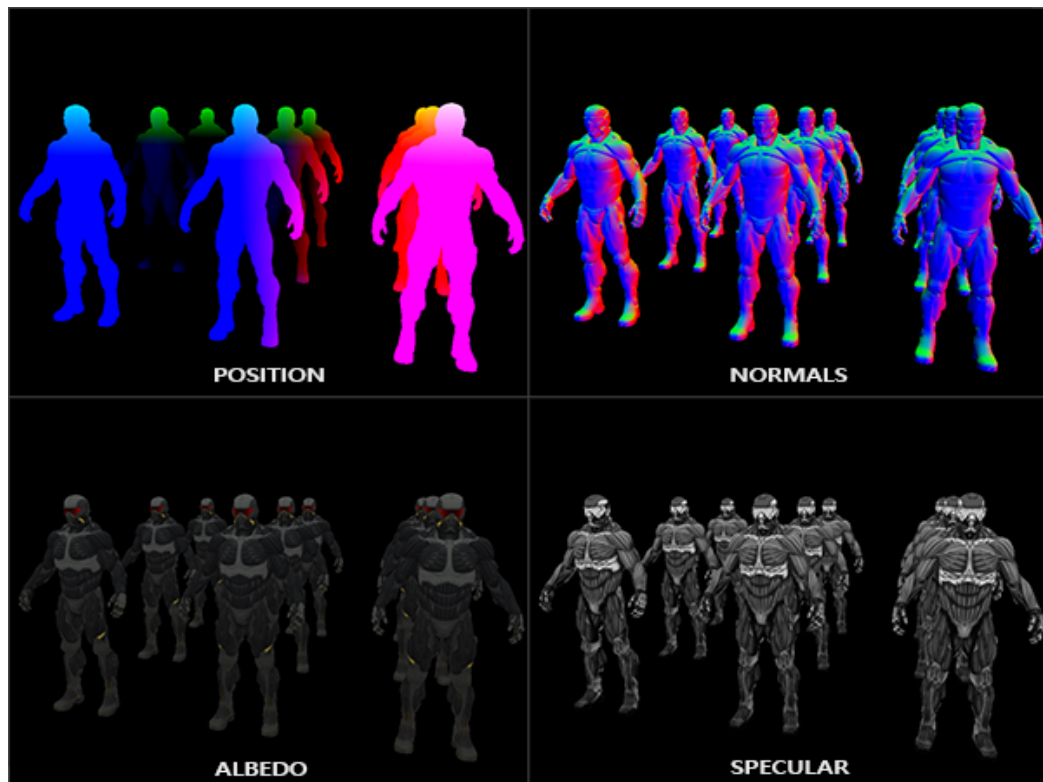

Try to visualize that the world-space position and normal vectors are indeed correct. For instance, the normal vectors pointing to the right would be more aligned to a red color, similar for position vectors that point from the scene's origin to the right. As soon as you're satisfied with the content of the G-buffer it's time to move to the next step: the lighting pass.

41.2 The deferred lighting pass

With a large collection of fragment data in the G-Buffer at our disposal we have the option to completely calculate the scene's final lighted colors by iterating over each of the G-Buffer textures pixel by pixel and use their content as input to the lighting algorithms. Because the G-buffer texture values all represent the final transformed fragment values we only have to do the expensive lighting operations once per pixel. This makes deferred shading quite efficient, especially in complex scenes where we'd easily invoke multiple expensive fragment shader calls per pixel in a forward rendering setting.

For the lighting pass we're going to render a 2D screen-filled quad (a bit like a post-processing effect) and execute an expensive lighting fragment shader on each pixel:

```
glClear(GL_COLOR_BUFFER_BIT | GL_DEPTH_BUFFER_BIT);
shaderLightingPass.Use();
glActiveTexture(GL_TEXTURE0);
glBindTexture(GL_TEXTURE_2D, gPosition);
glActiveTexture(GL_TEXTURE1);
glBindTexture(GL_TEXTURE_2D, gNormal);
glActiveTexture(GL_TEXTURE2);
glBindTexture(GL_TEXTURE_2D, gAlbedoSpec);
// Also send light relevant uniforms
SendAllLightUniformsToShader(shaderLightingPass);
```

```
glUniform3fv(glGetUniformLocation(shaderLightingPass.Program, "viewPos"),
             1, &camera.Position[0]);
RenderQuad();
```

We bind all relevant textures of the G-buffer before rendering and also send the lighting-relevant uniform variables to the shader.

The fragment shader of the lighting pass is largely similar to the lighting tutorial shaders we've used so far. What is new is the method in which we obtain the lighting's input variables which we now directly sample from the G-buffer:

```
#version 330 core
out vec4 FragColor;
in vec2 TexCoords;

uniform sampler2D gPosition;
uniform sampler2D gNormal;
uniform sampler2D gAlbedoSpec;

struct Light {
    vec3 Position;
    vec3 Color;
};
const int NR_LIGHTS = 32;
uniform Light lights[NR_LIGHTS];
uniform vec3 viewPos;

void main()
{
    // Retrieve data from G-buffer
    vec3 FragPos = texture(gPosition, TexCoords).rgb;
    vec3 Normal = texture(gNormal, TexCoords).rgb;
    vec3 Albedo = texture(gAlbedoSpec, TexCoords).rgb;
    float Specular = texture(gAlbedoSpec, TexCoords).a;

    // Then calculate lighting as usual
    vec3 lighting = Albedo * 0.1; // hard-coded ambient component
    vec3 viewDir = normalize(viewPos - FragPos);
    for(int i = 0; i < NR_LIGHTS; ++i)
    {
        // Diffuse
        vec3 lightDir = normalize(lights[i].Position - FragPos);
        vec3 diffuse = max(dot(Normal, lightDir), 0.0) * Albedo * lights[i].Color;
        lighting += diffuse;
    }

    FragColor = vec4(lighting, 1.0);
}
```

The lighting pass shader accepts 3 uniform textures that represent the G-buffer and hold all the data we've stored in the geometry pass. If we were to sample these with the current fragment's texture coordinates we'd get the exact same fragment values as if we were rendering the geometry directly. At the start of the fragment shader we retrieve the lighting-relevant variables from the G-buffer textures by a simple texture lookup. Note that we retrieve both the [Albedo](#) color and the [Specular](#) intensity from the single [gAlbedoSpec](#) texture.

As we now have the per-fragment variables necessary (and the relevant uniform variables) to calculate Blinn-Phong lighting we don't have to make any changes to the lighting code. The only thing we change in deferred shading is the method of obtaining lighting input variables.

Running a simple demo with a total of 32 small lights looks a bit like this:

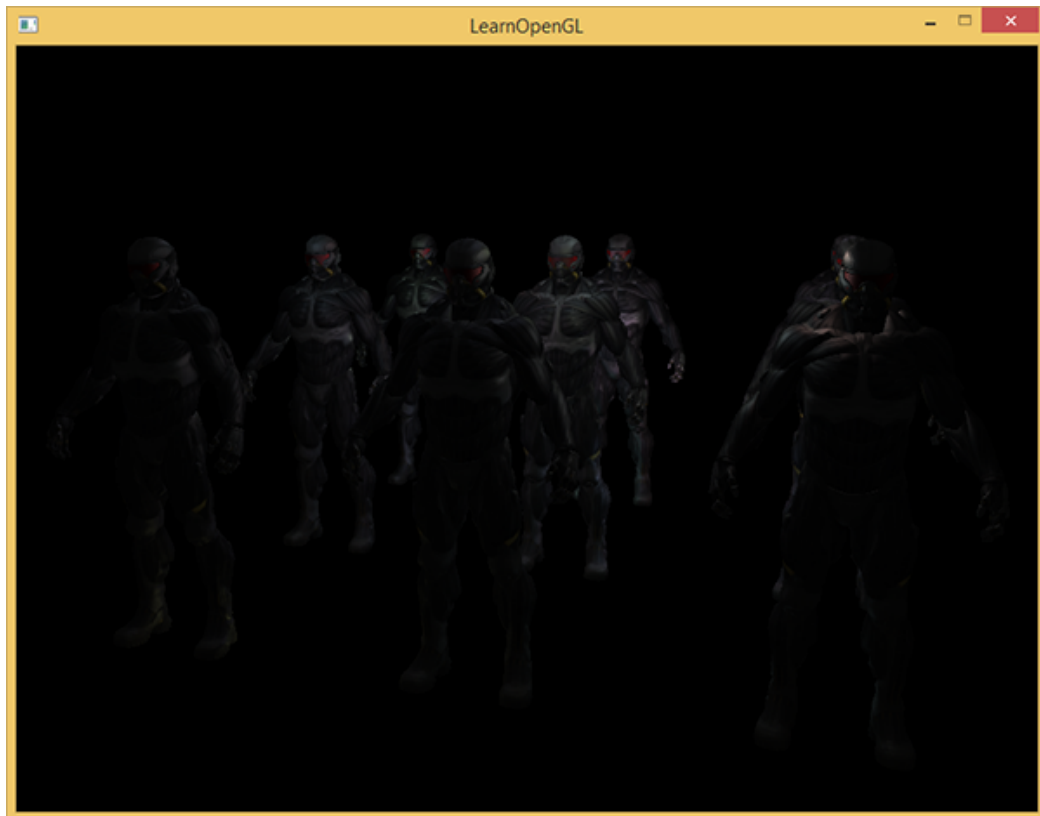

You can find the full source code of the demo [here](#) together with the geometry pass's [vertex](#) and [fragment](#) shader, and the lighting pass's [vertex](#) and [fragment](#) shader.

One of the disadvantages of deferred shading is that it is not possible to do [blending](#) as all values in the G-buffer are from single fragments, and blending operates on the combination of multiple fragments. Another disadvantage is that deferred shading forces you to use the same lighting algorithm for most of your scene's lighting; you can somehow alleviate this a bit by including more material-specific data in the G-buffer.

To overcome these disadvantages (especially blending) we often split the renderer into two parts: one deferred rendering part, and the other a forward rendering part specifically meant for blending or special shader effects not suited for a deferred rendering pipeline. To illustrate how this works we'll render the light sources as small cubes using a forward renderer as the light cubes require a special shader (simply output a single light color).

41.3 Combining deferred rendering with forward rendering

Say we want to render each of the light sources as a 3D cube positioned at the light source's position emitting the color of the light alongside the deferred renderer. A first idea that comes to mind is to

simply forward render all the light sources on top of the deferred lighting quad at the end of the deferred shading pipeline. So basically render the cubes as we'd normally do, but only after we've finished the deferred rendering operations. In code this will look a bit like this:

```
// Deferred lighting pass
[...]
```

```
RenderQuad();

// Now render all light cubes with forward rendering as we'd normally do
shaderLightBox.Use();
glUniformMatrix4fv(locProjection, 1, GL_FALSE, glm::value_ptr(projection));
glUniformMatrix4fv(locView, 1, GL_FALSE, glm::value_ptr(view));
for (GLuint i = 0; i < lightPositions.size(); i++)
{
    model = glm::mat4();
    model = glm::translate(model, lightPositions[i]);
    model = glm::scale(model, glm::vec3(0.25f));
    glUniformMatrix4fv(locModel, 1, GL_FALSE, glm::value_ptr(model));
    glUniform3fv(locLightcolor, 1, &lightColors[i][0]);
    RenderCube();
}
```

However, these rendered cubes do not take any of the stored geometry depth of the deferred renderer into account and are, as a result, always rendered on top of the previously rendered objects; this isn't the result we were looking for.



What we need to do is first copy the depth information stored in the geometry pass into the default framebuffer's depth buffer and only then render the light cubes. This way the light cubes' fragments are only rendered when on top of the previously rendered geometry.

We can copy the content of a framebuffer to the content of another framebuffer with the help of `glBlitFramebuffer`, a function we also used at the [anti-aliasing](#) tutorial to resolve multisampled framebuffers. The `glBlitFramebuffer` function allows us to copy a user-defined region of a framebuffer to a user-defined region of another framebuffer.

We stored the depth of all the objects rendered in the deferred shading pass in the `gBuffer` FBO. If we were to simply copy the content of its depth buffer to the depth buffer of the default framebuffer, the light cubes would then render as if all of the scene's geometry was rendered with forward rendering. As briefly explained in the anti-aliasing tutorial we have to specify a framebuffer as the read framebuffer and similarly specify a framebuffer as the write framebuffer:

```
glBindFramebuffer(GL_READ_FRAMEBUFFER, gBuffer);
glBindFramebuffer(GL_DRAW_FRAMEBUFFER, 0); // Write to default framebuffer
glBlitFramebuffer(
    0, 0, SCR_WIDTH, SCR_HEIGHT, 0, 0, SCR_WIDTH, SCR_HEIGHT,
    GL_DEPTH_BUFFER_BIT, GL_NEAREST
);
glBindFramebuffer(GL_FRAMEBUFFER, 0);
// Now render light cubes as before
[...]
```

Here we copy the entire read framebuffer's depth buffer content to the default framebuffer's depth buffer; this can similarly be done for colorbuffers and stencil buffers. Now if we then render the light cubes, the cubes indeed act as if the scene's geometry is real and not simply pasted on top of a 2D quad:



You can find the full source code of the demo [here](#) together with the light cube's [vertex](#) and [fragment](#) shader.

With this approach we can easily combine deferred shading with forward shading. This is great as we can now still apply blending and render objects that require special shader effects, something that isn't possible in a deferred rendering context.

41.4 A larger number of lights

What deferred rendering is often praised for is its ability to render an enormous amount of light sources without a heavy cost on performance. Deferred rendering by itself doesn't allow for a very large amount of light sources as we'd still have to calculate each fragment's lighting component for each of the scene's light sources. What makes a large amount of light sources possible is a very neat optimization we can apply to the deferred rendering pipeline: that of [light volumes](#).

Normally when we'd render a fragment in a large lighted scene we'd calculate the contribution of **each** light source in a scene, regardless of their distance to the fragment. A large portion of these light sources will never reach the fragment so why waste all the lighting computations?

The idea behind light volumes is to calculate the radius or volume of a light source i.e. the area where its light is able to reach fragments. As most light sources use some form of attenuation we can use that to calculate the maximum distance or radius their light is able to reach. We then only do the expensive lighting calculations if a fragment is inside one or more of these light volumes. This can save us a considerable amount of computation as we now only calculate lighting where it's necessary.

The trick to this approach is mostly figuring out the size or radius of the light volume of a light source.

41.4.1 Calculating a light's volume or radius

To obtain a light's volume radius we'd basically have to solve the attenuation equation for a brightness we deem as *dark*, this can be 0.0 or something slightly more lit but still considered dark like 0.03. To demonstrate how we can calculate a light's volume radius we'll use one of the more difficult, but extensive attenuation functions that we've introduced in the [light casters](#) tutorial:

$$F_{light} = \frac{I}{K_c + K_l * d + K_q * d^2}$$

What we want to do is solve this equation for when F_{light} is 0.0, when the light is completely dark at that distance. However, this equation will never exactly reach the value 0.0 so there won't be a solution. What we can do however is not solve the equation for 0.0, but solve it for a brightness value that is close to 0.0 but still perceived as dark. The brightness value we choose as acceptable for this tutorial's demo scene is 5/256; divided by 256 as the default 8-bit framebuffer can display that many intensities per component.

The attenuation function used is mostly dark in its visible range so if we were to limit it to an even darker brightness than $5/256$ the light volume would become too large and thus less effective. As long as a user cannot see a sudden cut-off of a light source at its volume borders we'll be fine. Of course this always depends on the type of scene; a higher brightness threshold results in smaller light volumes and thus a better efficiency, but can produce noticeable artifacts where lighting seems to break at a volume's borders.

The attenuation equation we have to solve becomes:

$$\frac{5}{256} = \frac{I_{max}}{Attenuation}$$

Here I_{max} is the light source's brightest color component. We use a light source's brightest color component, as solving the equation for a light's brightest intensity value best reflects the ideal light volume radius.

From here on we continue solving the equation:

$$\frac{5}{256} * Attenuation = I_{max}$$

$$5 * Attenuation = I_{max} * 256$$

$$Attenuation = I_{max} * \frac{256}{5}$$

$$K_c + K_l * d + K_q * d^2 = I_{max} * \frac{256}{5}$$

$$K_q * d^2 + K_l * d + K_c - I_{max} * \frac{256}{5} = 0$$

The last equation is an equation of the form $ax^2 + bx + c = 0$ which we can solve using the quadratic equation:

$$x = \frac{-K_l + \sqrt{K_l^2 - 4 * K_q * (K_c - I_{max} * \frac{256}{5})}}{2 * K_q}$$

This gives us a general equation that allows us to calculate x i.e. the light volume's radius for the light source given a constant, linear and quadratic parameter:

```

GLfloat constant = 1.0;
GLfloat linear   = 0.7;
GLfloat quadratic = 1.8;
GLfloat lightMax = std::fmaxf(std::fmaxf(lightColor.r, lightColor.g),
    lightColor.b);
GLfloat radius   =
    (-linear + std::sqrtf(linear * linear - 4 * quadratic * (constant - (256.0
        / 5.0) * lightMax)))
    / (2 * quadratic);

```

This returns a radius between roughly 1.0 and 5.0 based on the light's maximum intensity.

We calculate this radius for each light source of the scene and use it to only calculate lighting for that light source if a fragment is inside the light source's volume. Below is the updated lighting pass fragment shader that takes into account the calculated light volumes. Note that this approach is merely done for teaching purposes and not viable in a practical setting as we'll soon discuss:

```

struct Light {
    [...]
    float Radius;
};

void main()
{
    [...]
    for(int i = 0; i < NR_LIGHTS; ++i)
    {
        // Calculate distance between light source and current fragment
        float distance = length(lights[i].Position - FragPos);
        if(distance < lights[i].Radius)
        {
            // do expensive lighting
            [...]
        }
    }
}

```

The results are exactly the same as before, but this time each light only calculates lighting for the light sources in which volume it resides.

You can find the final source code of the demo [here](#) together with the lighting pass's updated [fragment](#) shader.

41.4.2 How we really use light volumes

The fragment shader shown above doesn't really work in practice and only illustrates how we can *sort of* use a light's volume to reduce the lighting calculations. The reality is that your GPU and GLSL are really bad at optimizing loops and branches. The reason for this is that shader execution on the GPU is highly parallel and most architectures have a requirement that for large collection of threads they need to run the exact same shader code for it to be efficient. This often means that a shader is run that always executes all branches of an `if` statement to ensure the shader runs are the same, making our previous *radius check* optimization completely useless; we'd still calculate lighting for all light sources!

The appropriate approach to using light volumes is to render actual spheres, scaled by the light volume radius. The center of these spheres are positioned at the light source's position and as it is scaled by the light volume radius the sphere exactly encompasses the light's visible volume. This is where the trick comes in: we use largely the same deferred fragment shader for rendering the sphere. As the rendered sphere produces fragment shader invocations that exactly match the pixels the light source affects, we only render the relevant pixels and skip all other pixels. The image below illustrates this:

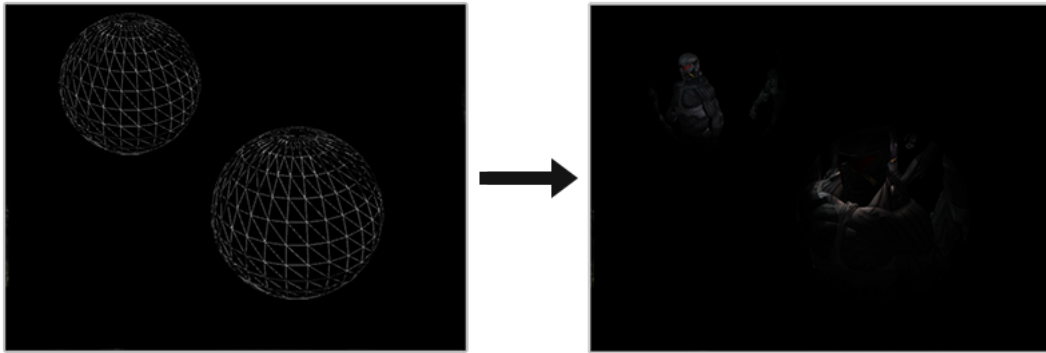

This is done for each light source in the scene and the resulting fragments are additively blended together. The result is then the exact same scene as before, but this time rendering only the relevant fragments per light source. This effectively reduces the computations from $nr_objects * nr_lights$ to $nr_objects + nr_lights$ which makes it incredibly efficient in scenes with a large number of lights. This approach is what makes deferred rendering so suitable for rendering a large number of lights.

There is still an issue with this approach: face culling should be enabled (otherwise we'd render a light's effect twice) and when it is enabled the user might enter a light source's volume after which the volume isn't rendered anymore (due to back-face culling), removing the light source's influence; this can be solved with a neat stencil buffer trick.

Rendering light volumes does take a heavy toll on performance and while it is generally faster than normal deferred shading it's not the best optimization. Two other popular extensions on top of deferred shading exist called [deferred lighting](#) and [tile-based deferred shading](#). These are incredibly efficient at rendering large amounts of light and also allow for relatively efficient MSAA. However, for the sake of this tutorial's length I'll leave these optimizations for a later tutorial (take a look at the OGLDev tutorials and the slides by Andrew Lauritzen at the end).

41.5 Deferred rendering vs forward rendering

By itself (without light volumes) deferred shading is already a large optimization as each pixel only runs a single fragment shader, compared to forward rendering where we'd often run the fragment shader multiple times per pixel. Deferred rendering does come with a few disadvantages though: a large memory overhead, no MSAA and blending still has to be done with forward rendering.

When you have a small scene and not too many lights, deferred rendering is not necessarily faster and sometimes even slower as the overhead then outweighs the benefits of deferred rendering. In more complex scenes deferred rendering quickly becomes a significant optimization; especially when rendering with light volumes.

As a final note I'd also like to mention that basically all effects that can be accomplished with forward rendering can also be implemented in a deferred rendering context; this often only requires a small translation step. For instance, if we want to use normal mapping in a deferred renderer, we'd change the geometry pass shaders to output a world-space normal extracted from a normal map (using a TBN matrix) instead of the surface normal; the lighting calculations in the lighting pass don't need to change at all. And if you want parallax mapping to work, you'd want to first displace the texture coordinates in the geometry pass before sampling an object's diffuse, specular or normal textures. Once you understand the idea behind deferred rendering, it's not too difficult to get creative.

41.6 Additional resources

- [Tutorial 35: Deferred Shading - Part 1](#): a three-part deferred shading tutorial by OGLDev. In part 2 and 3 the topic of rendering light volumes is discussed.
- [Deferred Rendering for Current and Future Rendering Pipelines](#): slides by Andrew Lauritzen discussing high-level tile-based deferred shading and deferred lighting.

42. SSAO

We've briefly touched on it in the basic lighting tutorial: ambient lighting. Ambient lighting is a fixed light constant we add to the overall lighting of a scene to simulate the **scattering** of light. In reality, light scatters in all kinds of directions with varying intensities so the indirectly lit parts of a scene should also have varying intensities, instead of a constant ambient component. One type of indirect lighting approximation is called **ambient occlusion** that tries to approximate indirect lighting by darkening creases, holes and surfaces that are close to each other. These areas are largely occluded by surrounding geometry and thus light rays have less places to escape, hence the areas appear darker. Take a look at the corners and creases of your room to see that light seems just a little darker.

Below is an example image of a scene with and without SSAO. Notice how especially between the creases the (ambient) light is more occluded:



While not an incredibly obvious effect, the image with SSAO enabled does feel a lot more realistic due to these small occlusion-like details, giving the entire scene a greater feel of depth.

Ambient occlusion techniques are expensive as they have to take surrounding geometry into account. One could shoot a large number of rays for each point in space to determine its amount of occlusion, but that quickly becomes computationally infeasible for real-time solutions. In 2007 Crytek published a technique called **screen-space ambient occlusion (SSAO)** for use in their title *Crysis*. The technique uses a scene's depth in screen-space to determine the amount of occlusion instead of real geometrical data. This approach is incredibly fast compared to real ambient occlusion and gives plausible results, making it the de-facto standard for approximating real-time ambient occlusion.

The basics behind screen-space ambient occlusion are simple: for each fragment on a screen-filled quad we calculate an **occlusion factor** based on the fragment's surrounding depth values. The occlusion factor is then used to reduce or nullify the fragment's ambient lighting component. The occlusion factor is obtained by taking multiple depth samples in a sphere sample kernel surrounding the fragment position and compare each of the samples with the current fragment's depth value. The number of samples that have a higher depth value than the fragment's depth represents the occlusion factor.

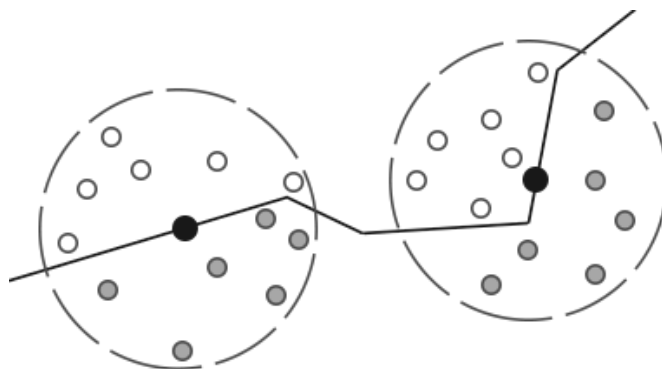

Each of the gray depth samples that are inside geometry contribute to the total occlusion factor; the more samples we find inside geometry, the less ambient lighting the fragment should eventually receive.

It is clear the quality and precision of the effect directly relates to the number of surrounding samples we take. If the sample count is too low the precision drastically reduces and we get an artifact called **banding**; if it is too high we lose performance. We can reduce the amount of samples we have to test by introducing some randomness into the sample kernel. By randomly rotating the sample kernel each fragment we can get high quality results with a much smaller amount of samples. This does come at a price as the randomness introduces a noticeable **noise pattern** that we'll have to fix by blurring the results. Below is an image (courtesy of [John Chapman](#)) showcasing the banding effect and the effect randomness has on the results:

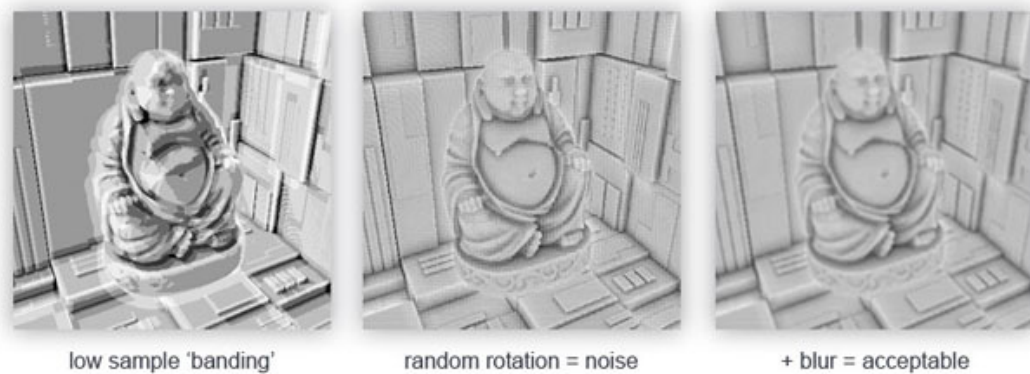

As you can see, even though we get noticeable banding on the SSAO results due to a low sample count, by introducing some randomness the banding effects are completely gone.

The SSAO method developed by Crytek had a certain visual style. Because the sample kernel used was a sphere, it caused flat walls to look gray as half of the kernel samples end up being in the surrounding geometry. Below is an image of Crysis's screen-space ambient occlusion that clearly portrays this gray feel:



For that reason we won't be using a sphere sample kernel, but rather a hemisphere sample kernel oriented along a surface's normal vector.

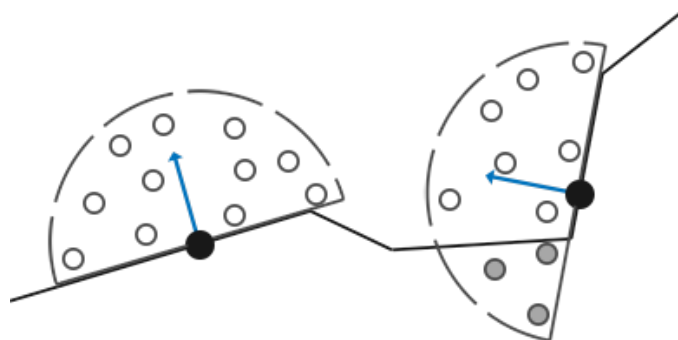

By sampling around this [normal-oriented hemisphere](#) we do not consider the fragment's underlying geometry as contribution to the occlusion factor. This removes the gray-feel of ambient occlusion and generally produces more realistic results. This SSAO tutorial is based on this normal-oriented hemisphere method and a slightly modified version of John Chapman's brilliant [SSAO tutorial](#).

42.1 Sample buffers

SSAO requires geometrical info as we need some way to determine the occlusion factor of a fragment. For each fragment, we're going to need the following data:

- A per-fragment **position** vector.
- A per-fragment **normal** vector.
- A **linear depth** texture.
- A **sample kernel**.
- A per-fragment **random rotation** vector used to rotate the sample kernel.

Using a per-fragment view-space position we can orient a sample hemisphere kernel around the fragment's view-space surface normal and for each kernel sample we sample the linear depth texture to compare the results. The sample kernel is slightly rotated based on a per-fragment rotation vector; the resulting occlusion factor is then used to limit the final ambient lighting component.

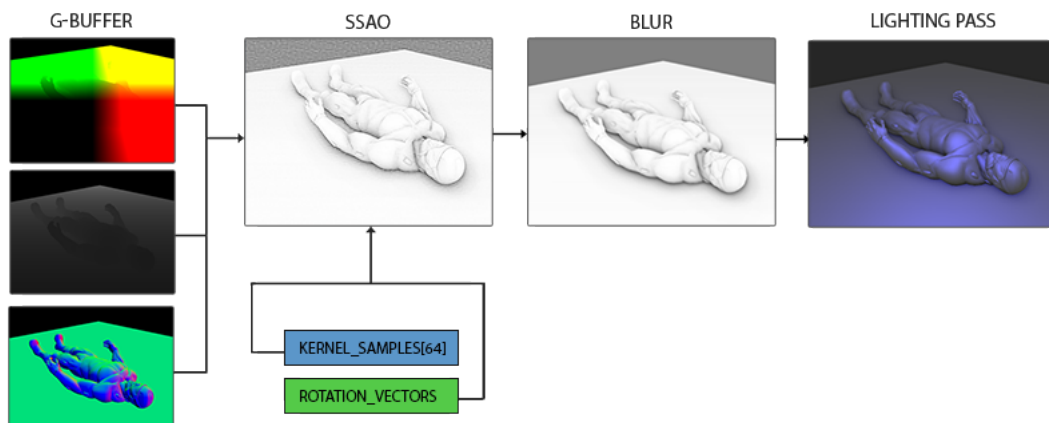

As SSAO is a screen-space technique we calculate its effect on each fragment on a screen-filled 2D quad; we thus have no geometrical information of the scene. What we can do is render the geometrical per-fragment data into screen-space textures that we then later send to the SSAO shader so we have access to the per-fragment geometrical data. If you've followed along with the previous tutorial you'll realize this looks largely similar to deferred rendering and for that reason SSAO is perfectly suited in combination with deferred rendering as we already have the position and normal vectors in the G-buffer.

In this tutorial we're going to implement SSAO on top of a slightly simplified version of the deferred renderer from the [deferred shading](#) tutorial so if you're not sure what deferred shading is be sure to first read up on that.

As we already have per-fragment position and normal data available from the G-buffer we'll only need to update the geometry shader to also include the linear depth of each fragment.

As we've already learned from the [depth testing](#) tutorial we can extract the linear depth from `gl_FragCoord.z` as follows:

```
#version 330 core
layout (location = 0) out vec4 gPositionDepth;
layout (location = 1) out vec3 gNormal;
layout (location = 2) out vec4 gAlbedoSpec;

in vec2 TexCoords;
in vec3 FragPos;
in vec3 Normal;

const float NEAR = 0.1; // projection matrix's near plane
const float FAR = 50.0f; // projection matrix's far plane
float LinearizeDepth(float depth)
{
    float z = depth * 2.0 - 1.0; // Back to NDC
    return (2.0 * NEAR * FAR) / (FAR + NEAR - z * (FAR - NEAR));
}

void main()
{
    // Store the fragment position vector in the first gbuffer texture
    gPositionDepth.xyz = FragPos;
    // And store linear depth into gPositionDepth's alpha component
    gPositionDepth.a = LinearizeDepth(gl_FragCoord.z);
    // Also store the per-fragment normals into the gbuffer
    gNormal = normalize(Normal);
    // And the diffuse per-fragment color
    gAlbedoSpec.rgb = vec3(0.95);
}
```

The extracted linear depth is in view space so all further calculations are in view-space as well. Make sure the G-buffer's positions and normals are in view-space (multiplied by the view matrix as well). The view-space linear depth value is then stored as the `gPositionDepth` colorbuffer's alpha component to save us from having to declare another colorbuffer texture.

It is possible to reconstruct the actual position vectors from depth values alone using some clever tricks as Matt Pettineo described in his [blog](#). This requires some extra calculations in the shaders, but saves us from having to store position data in the G-buffer which costs a lot of memory. For the sake of a simple example, we'll leave these optimizations out of the tutorial.

The `gPositionDepth` colorbuffer texture is now configured as follows:

```
glGenTextures(1, &gPositionDepth);
glBindTexture(GL_TEXTURE_2D, gPositionDepth);
glTexImage2D(GL_TEXTURE_2D, 0, GL_RGBA16F, SCR_WIDTH, SCR_HEIGHT, 0,
             GL_RGBA, GL_FLOAT, NULL);
glTexParameteri(GL_TEXTURE_2D, GL_TEXTURE_MIN_FILTER, GL_NEAREST);
glTexParameteri(GL_TEXTURE_2D, GL_TEXTURE_MAG_FILTER, GL_NEAREST);
glTexParameteri(GL_TEXTURE_2D, GL_TEXTURE_WRAP_S, GL_CLAMP_TO_EDGE);
glTexParameteri(GL_TEXTURE_2D, GL_TEXTURE_WRAP_T, GL_CLAMP_TO_EDGE);
```

This gives us a linear depth texture that we can use to obtain depth values for each of the kernel samples. Note that we store the linear depth values in a floating point data-format; this way the depth values between 0.1 and 50.0 aren't clamped to $[0.0, 1.0]$. If you're not using a floating point format to store depth values, be sure to first normalize them before storing them into the `gPositionDepth` texture by dividing its values by `FAR`, and similarly re-construct them in a later shader. Also note the texture wrapping method of `GL_CLAMP_TO_EDGE`. This ensures we don't accidentally oversample depth values in screen-space outside the texture's default coordinate region.

Next we need the actual hemisphere sample kernel and some method to randomly rotate it.

42.2 Normal-oriented hemisphere

We need to generate a number of samples oriented along the normal of a surface. As we briefly discussed at the start of this tutorial we want to generate samples that form a hemisphere. As it is difficult nor plausible to generate a sample kernel for each surface normal direction we're going to generate a sample kernel in **tangent space**, with the normal vector pointing in the positive z direction.

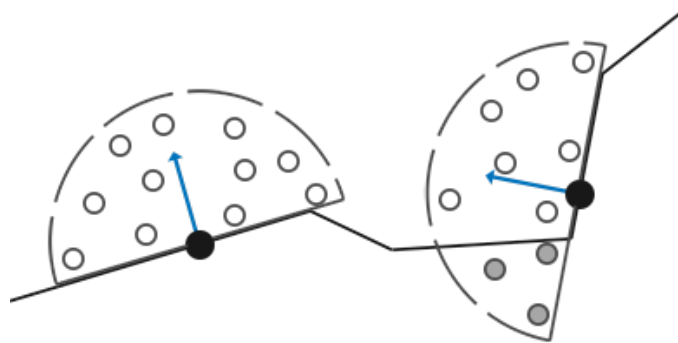

Assuming we have a unit hemisphere we can obtain a sample kernel with a maximum of 64 sample values as follows:

```
std::uniform_real_distribution<GLfloat> randomFloats(0.0, 1.0); // random
floats between 0.0 - 1.0
std::default_random_engine generator;
std::vector<glm::vec3> ssaoKernel;
for (GLuint i = 0; i < 64; ++i)
{
    glm::vec3 sample(
        randomFloats(generator) * 2.0 - 1.0,
        randomFloats(generator) * 2.0 - 1.0,
        randomFloats(generator)
    );
    sample = glm::normalize(sample);
    sample *= randomFloats(generator);
    GLfloat scale = GLfloat(i) / 64.0;
    ssaoKernel.push_back(sample);
}
```

We vary the x and y direction in tangent space between -1.0 and 1.0 and vary the z direction of the samples between 0.0 and 1.0 (if we varied the z direction between -1.0 and 1.0 as well

we'd have a sphere sample kernel). As the sample kernel will be oriented along the surface normal, the resulting sample vectors will all end up in the hemisphere.

Currently, all samples are evenly distributed in the sample kernel, but we'd rather place a larger weight on occlusions close to the actual fragment as to distribute the kernel samples closer to the origin. We can do this with an accelerating interpolation function:

```
scale = lerp(0.1f, 1.0f, scale * scale);
sample *= scale;
ssaoKernel.push_back(sample);
}
```

Where `lerp` is defined as:

```
GLfloat lerp(GLfloat a, GLfloat b, GLfloat f)
{
    return a + f * (b - a);
}
```

This gives us kernel distribution that places most samples closer to its origin.

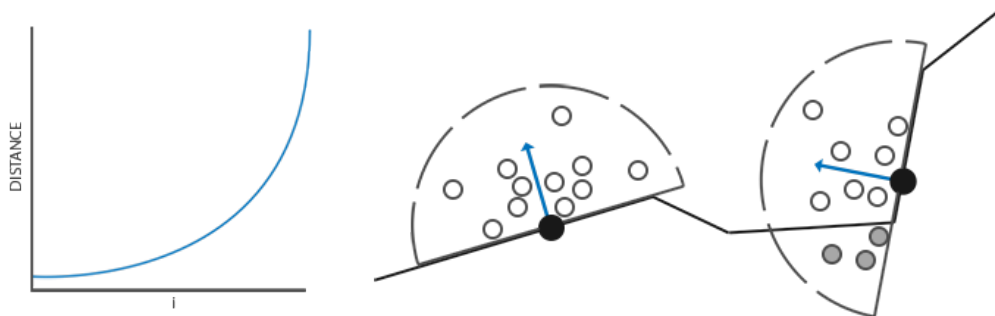

Each of the kernel samples will be used to offset the view-space fragment position to sample surrounding geometry. We saw at the start of this tutorial that without varying the sample kernel each fragment we'll need quite a few samples to get realistic results. By introducing a random rotation to the sample kernel each fragment we can significantly reduce the number of samples required.

42.3 Random kernel rotations

By introducing some randomness onto the sample kernels we largely reduce the number of samples necessary to get good results. We could create a random rotation vector for each fragment of a scene, but that quickly eats up memory. It makes more sense to create a small texture of random rotation vectors that we tile over the screen.

We create a 4x4 array of random rotation vectors oriented around the tangent-space surface normal:

```
std::vector<glm::vec3> ssaoNoise;
for (GLuint i = 0; i < 16; i++)
{
    glm::vec3 noise(
```

```

    randomFloats(generator) * 2.0 - 1.0,
    randomFloats(generator) * 2.0 - 1.0,
    0.0f);
    ssaoNoise.push_back(noise);
}

```

As the sample kernel is oriented along the positive z direction in tangent space we leave the z component at 0.0 so we rotate around the z axis.

We then create a 4x4 texture that holds the random rotation vectors; make sure to set its wrapping method to `GL_REPEAT` so it properly tiles over the screen.

```

GLuint noiseTexture;
glGenTextures(1, &noiseTexture);
glBindTexture(GL_TEXTURE_2D, noiseTexture);
glTexImage2D(GL_TEXTURE_2D, 0, GL_RGB16F, 4, 4, 0, GL_RGB, GL_FLOAT, &
    ssaoNoise[0]);
glTexParameteri(GL_TEXTURE_2D, GL_TEXTURE_MIN_FILTER, GL_NEAREST);
glTexParameteri(GL_TEXTURE_2D, GL_TEXTURE_MAG_FILTER, GL_NEAREST);
glTexParameteri(GL_TEXTURE_2D, GL_TEXTURE_WRAP_S, GL_REPEAT);
glTexParameteri(GL_TEXTURE_2D, GL_TEXTURE_WRAP_T, GL_REPEAT);

```

We now have all the relevant input data we need to implement SSAO.

42.4 The SSAO shader

The SSAO shader runs on a 2D screen-filled quad that calculates the occlusion value for each of the generated fragments (for use in the final lighting shader). As we need to store the result of the SSAO stage we create yet another framebuffer object:

```

GLuint ssaoFBO;
glGenFramebuffers(1, &ssaoFBO);
glBindFramebuffer(GL_FRAMEBUFFER, ssaoFBO);
GLuint ssaoColorBuffer;

glGenTextures(1, &ssaoColorBuffer);
glBindTexture(GL_TEXTURE_2D, ssaoColorBuffer);
glTexImage2D(GL_TEXTURE_2D, 0, GL_RED, SCR_WIDTH, SCR_HEIGHT, 0, GL_RGB,
    GL_FLOAT, NULL);
glTexParameteri(GL_TEXTURE_2D, GL_TEXTURE_MIN_FILTER, GL_NEAREST);
glTexParameteri(GL_TEXTURE_2D, GL_TEXTURE_MAG_FILTER, GL_NEAREST);
glFramebufferTexture2D(GL_FRAMEBUFFER, GL_COLOR_ATTACHMENT0, GL_TEXTURE_2D,
    ssaoColorBuffer, 0);

```

As the ambient occlusion result is a single grayscale value we'll only need a texture's red component thus we set the colorbuffer's internal format to `GL_RED`.

The complete process for rendering SSAO then looks a bit like this:

```

// geometry pass: render stuff into G-buffer
glBindFramebuffer(GL_FRAMEBUFFER, gBuffer);
[...]
glBindFramebuffer(GL_FRAMEBUFFER, 0);

```

```
// use G-buffer to render SSAO texture
glBindFramebuffer(GL_FRAMEBUFFER, ssaoFBO);
  glClear(GL_COLOR_BUFFER_BIT);
  shaderSSAO.Use();
  glActiveTexture(GL_TEXTURE0);
  glBindTexture(GL_TEXTURE_2D, gPositionDepth);
  glActiveTexture(GL_TEXTURE1);
  glBindTexture(GL_TEXTURE_2D, gNormal);
  glActiveTexture(GL_TEXTURE2);
  glBindTexture(GL_TEXTURE_2D, noiseTexture);
  SendKernelSamplesToShader();
  glUniformMatrix4fv(projLocation, 1, GL_FALSE, glm::value_ptr(projection));
  RenderQuad();
glBindFramebuffer(GL_FRAMEBUFFER, 0);

// lighting pass: render scene lighting
glClear(GL_COLOR_BUFFER_BIT | GL_DEPTH_BUFFER_BIT);
shaderLightingPass.Use();
[...]
glActiveTexture(GL_TEXTURE3);
glBindTexture(GL_TEXTURE_2D, ssaoColorBuffer);
[...]
RenderQuad();
```

The `shaderSSAO` shader takes as input the relevant G-buffer textures (including the linear depth), the noise texture and the normal-oriented hemisphere kernel samples:

```
#version 330 core
out float FragColor;
in vec2 TexCoords;

uniform sampler2D gPositionDepth;
uniform sampler2D gNormal;
uniform sampler2D texNoise;

uniform vec3 samples[64];
uniform mat4 projection;

// tile noise texture over screen based on screen dimensions divided by
// noise size
const vec2 noiseScale = vec2(800.0/4.0, 600.0/4.0); // screen = 800x600

void main()
{
}
```

Interesting to note here is the `noiseScale` variable. We want to tile the noise texture all over the screen, but as the `TexCoords` vary between 0.0 and 1.0 the `texNoise` texture wouldn't tile at all. So we'll calculate by how much we'll have to scale the `TexCoords` coordinates by dividing the screen's dimensions by the noise texture size; that we then use when we retrieve the relevant input vectors:

```
vec3 fragPos = texture(gPositionDepth, TexCoords).xyz;
vec3 normal = texture(gNormal, TexCoords).rgb;
vec3 randomVec = texture(texNoise, TexCoords * noiseScale).xyz;
```

As we set the tiling parameters of `texNoise` to `GL_REPEAT` the random values will be repeated all over the screen. Together with the `fragPos` and `normal` vector we then have enough data to create a TBN matrix that transforms any vector from tangent-space to view-space:

```
vec3 tangent = normalize(randomVec - normal * dot(randomVec, normal));
vec3 bitangent = cross(normal, tangent);
mat3 TBN = mat3(tangent, bitangent, normal);
```

Using a process called the **Gramm-Schmidt process** we create an orthogonal basis, each time slightly tilted based on the value of `randomVec`. Note that because we use a random vector for constructing the tangent vector, there is no need to have the TBN matrix exactly aligned to the geometry's surface, thus no need for per-vertex tangent (and bitangent) vectors.

Next we iterate over each of the kernel samples, transform the samples from tangent to view-space, add them to the current fragment position and compare the fragment position's depth with the sample depth stored in the original depth buffer. Let's discuss it in a step-by-step fashion:

```
float occlusion = 0.0;
for(int i = 0; i < kernelSize; ++i)
{
    // get sample position
    vec3 sample = TBN * samples[i]; // From tangent to view-space
    sample = fragPos + sample * radius;

    [...]
}
```

Here `kernelSize` and `radius` are variables that we can use to tweak the effect; in this case kept to their default values of `64` and `1.0` respectively. For each iteration we first transform the respective sample to view-space. We then add the view-space kernel offset sample to the view-space fragment position; we multiply the offset sample by `radius` to increase (or decrease) the effective sample radius of SSAO.

Next we transform `sample` to screen-space so we can sample the (linear) depth value of `sample` as if we were rendering its position directly to the screen. As the vector is currently in view-space, we'll transform it to clip-space first using the `projection` matrix uniform:

```
vec4 offset = vec4(sample, 1.0);
offset = projection * offset; // from view to clip-space
offset.xyz /= offset.w; // perspective divide
offset.xyz = offset.xyz * 0.5 + 0.5; // transform to range 0.0 - 1.0
```

After the variable is transformed to clip-space we perform the perspective divide step by dividing its `xyz` components with its `w` component. The resulting normalized device coordinates are then transformed to the `[0.0, 1.0]` range so we can use them to sample the depth texture:

```
float sampleDepth = -texture(gPositionDepth, offset.xy).w;
```

We use the `offset` vector's `x` and `y` component to sample the linear depth texture to get the depth value of the sample position as seen from the viewer's perspective (so the first non-occluded visible fragment). We then check if the sample's current depth value is larger than the stored depth value and if so, we add to the final contribution factor:

```
occlusion += (sampleDepth >= sample.z ? 1.0 : 0.0);
```

We're not completely finished as there is still a small issue we have to take into account. Whenever a fragment is tested for ambient occlusion that is aligned close to the edge of a surface, it will also consider the depth values of surfaces far behind the test surface; these values will (incorrectly) contribute to the occlusion factor. We can solve this by introducing a range check as the following image (courtesy of [John Chapman](#)) illustrates:

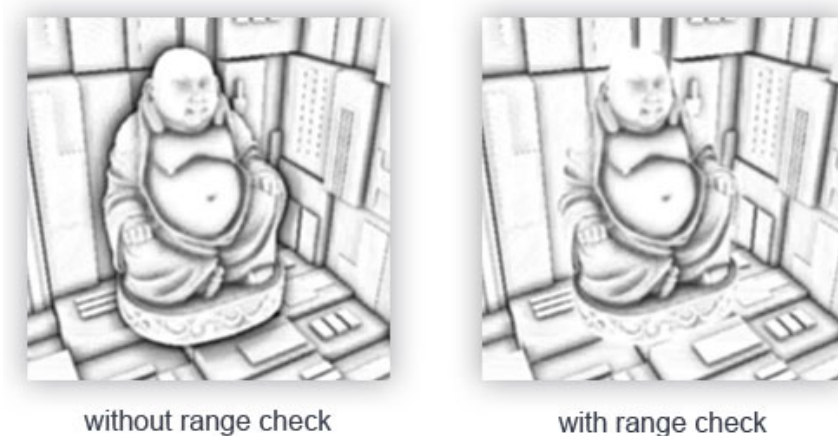

We introduce a range check that makes sure we only contribute to the occlusion factor if the depth values to test are within the sample's radius. We change the last line by:

```
float rangeCheck = smoothstep(0.0, 1.0, radius / abs(fragPos.z -
    sampleDepth));
occlusion += (sampleDepth >= sample.z ? 1.0 : 0.0) * rangeCheck;
```

Here we used GLSL's `smoothstep` function that smoothly interpolates its third parameter between the first and second parameter's range. If the depth difference thus ends up between `radius` their value gets smoothly interpolated between 0.0 and 1.0 by the following curve:

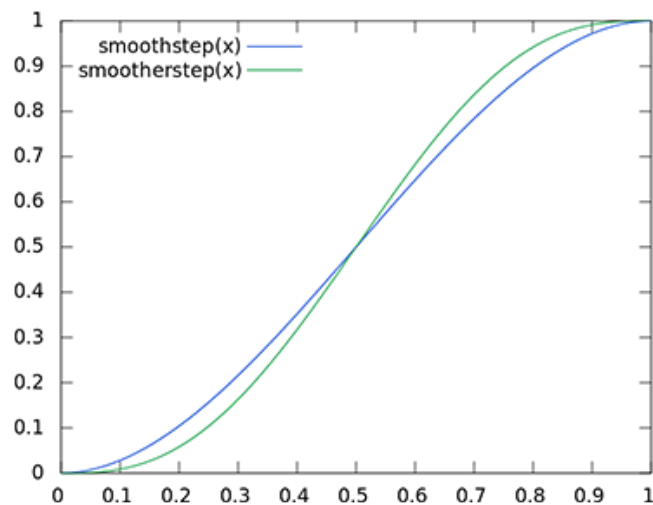

If we used a hard cut-off range check that abruptly removes occlusion contributions if the depth values are outside the `radius` we'd see obvious (unattractive) borders at where the range check is applied.

As a final step we'd normalize the occlusion contribution by the size of the kernel and output the results. Note that we subtract the occlusion factor from 1.0 so we can directly use the occlusion factor to scale the ambient lighting component.

```
}  
occlusion = 1.0 - (occlusion / kernelSize);  
FragColor = occlusion;
```

If we'd imagine a scene where our favorite nanosuit model is taking a little nap, the ambient occlusion shader produces the following texture:

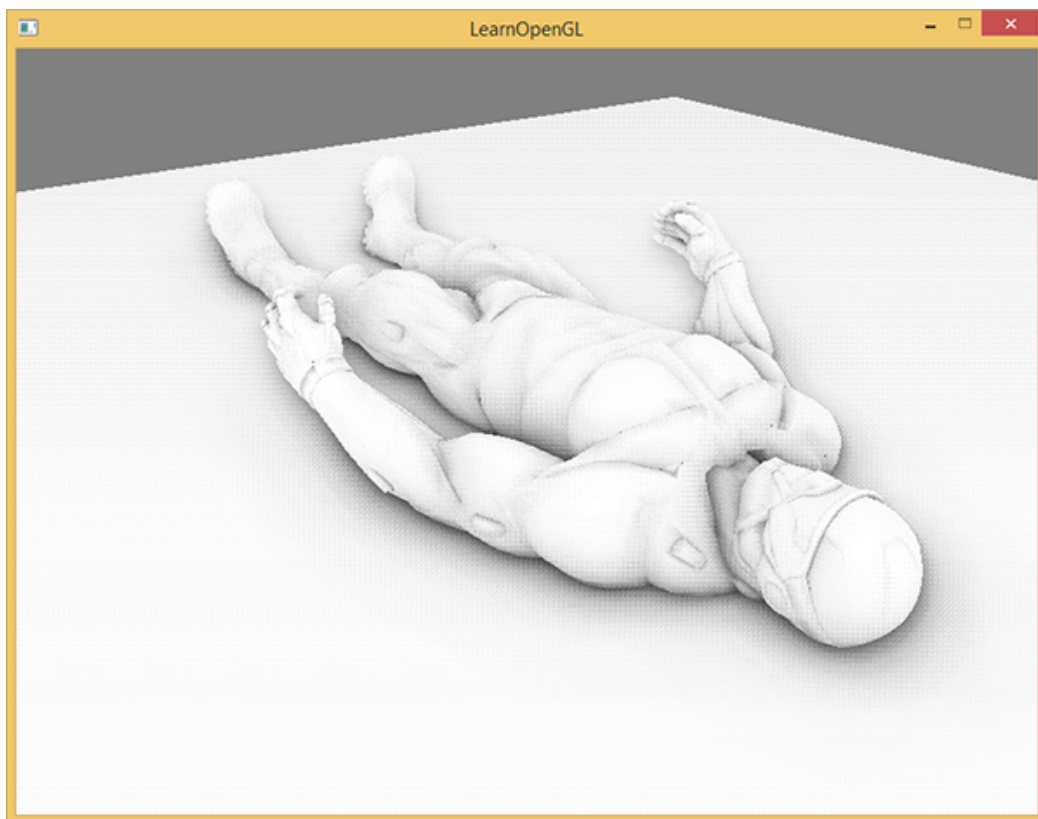

As we can see, ambient occlusion gives a great sense of depth. With just the ambient occlusion texture we can already clearly see the model is indeed laying on the floor instead of hovering slightly above it.

It still doesn't look perfect as the repeating pattern of the noise texture is clearly visible. To create a smooth ambient occlusion result we need to blur the ambient occlusion texture.

42.5 Ambient occlusion blur

Between the SSAO pass and the lighting pass we first want to blur the SSAO texture, so let's create yet another framebuffer object for storing the blur result:

```
GLuint ssaoBlurFBO, ssaoColorBufferBlur;  
glGenFramebuffers(1, &ssaoBlurFBO);  
glBindFramebuffer(GL_FRAMEBUFFER, ssaoBlurFBO);
```

```
glGenTextures(1, &ssaoColorBufferBlur);
glBindTexture(GL_TEXTURE_2D, ssaoColorBufferBlur);
glTexImage2D(GL_TEXTURE_2D, 0, GL_RED, SCR_WIDTH, SCR_HEIGHT, 0, GL_RGB,
             GL_FLOAT, NULL);
glTexParameteri(GL_TEXTURE_2D, GL_TEXTURE_MIN_FILTER, GL_NEAREST);
glTexParameteri(GL_TEXTURE_2D, GL_TEXTURE_MAG_FILTER, GL_NEAREST);
glFramebufferTexture2D(GL_FRAMEBUFFER, GL_COLOR_ATTACHMENT0, GL_TEXTURE_2D,
                      ssaoColorBufferBlur, 0);
```

Because the tiled random vector texture keeps a consistent randomness we can use this property to our advantage to create a very simple blur shader:

```
#version 330 core
in vec2 TexCoords;
out float fragColor;

uniform sampler2D ssaoInput;

void main() {
    vec2 texelSize = 1.0 / vec2(textureSize(ssaoInput, 0));
    float result = 0.0;
    for (int x = -2; x < 2; ++x)
    {
        for (int y = -2; y < 2; ++y)
        {
            vec2 offset = vec2(float(x), float(y)) * texelSize;
            result += texture(ssaoInput, TexCoords + offset).r;
        }
    }
    fragColor = result / (4.0 * 4.0);
}
```

Here we traverse the surrounding SSAO texels between -2.0 and 2.0 sampling the SSAO texture the identical amount as the noise texture's dimensions. We offset each texture coordinate by the exact size of a single texel using `textureSize` that returns a `vec2` of the given texture's dimensions. We average the obtained results to get a simple, but effective blur:

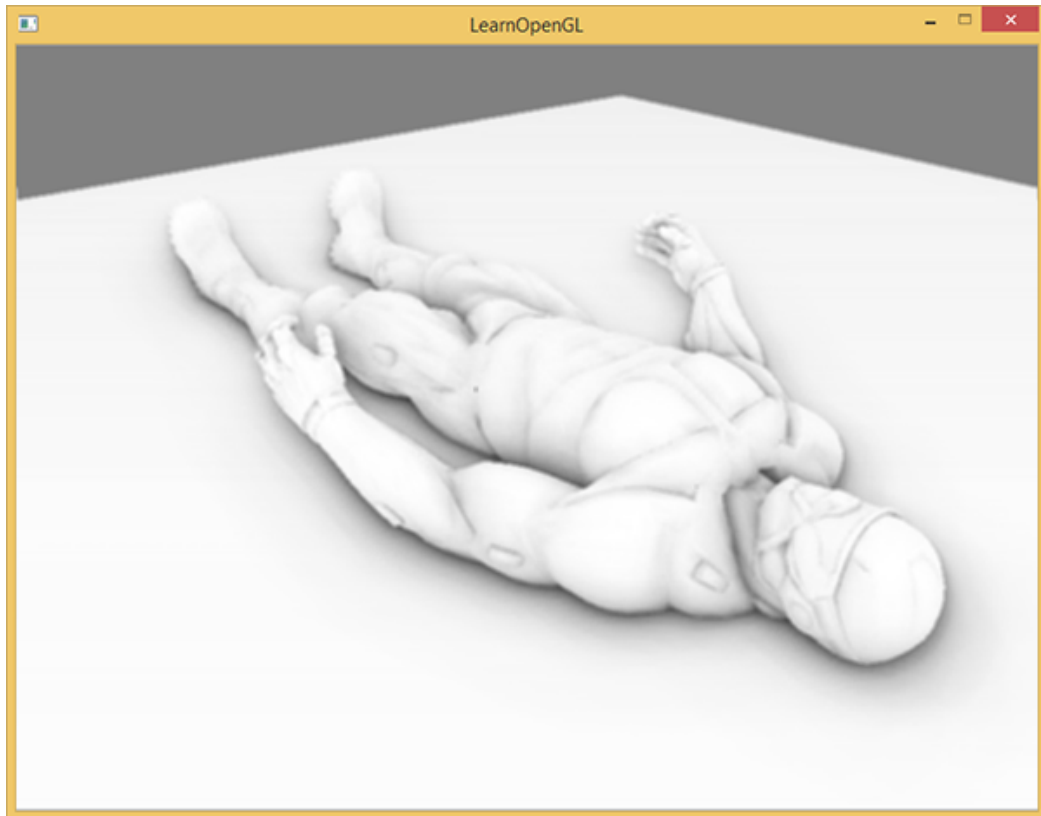

And there we go, a texture with per-fragment ambient occlusion data; ready for use in the lighting pass.

42.6 Applying ambient occlusion

Applying the occlusion factors to the lighting equation is incredibly easy: all we have to do is multiply the per-fragment ambient occlusion factor to the lighting's ambient component and we're done. If we take the Blinn-Phong deferred lighting shader of the previous tutorial and adjust it a bit we get the following fragment shader:

```
#version 330 core
out vec4 FragColor;
in vec2 TexCoords;

uniform sampler2D gPositionDepth;
uniform sampler2D gNormal;
uniform sampler2D gAlbedo;
uniform sampler2D ssao;

struct Light {
    vec3 Position;
    vec3 Color;

    float Linear;
    float Quadratic;
    float Radius;
};
uniform Light light;
```

```
void main()
{
    // Retrieve data from gbuffer
    vec3 FragPos = texture(gPositionDepth, TexCoords).rgb;
    vec3 Normal = texture(gNormal, TexCoords).rgb;
    vec3 Diffuse = texture(gAlbedo, TexCoords).rgb;
    float AmbientOcclusion = texture(ssao, TexCoords).r;

    // Blinn-Phong (in view-space)
    vec3 ambient = vec3(0.3 * AmbientOcclusion); // Here we add occlusion
    factor
    vec3 lighting = ambient;
    vec3 viewDir = normalize(-FragPos); // Viewpos is (0.0.0) in view-space
    // Diffuse
    vec3 lightDir = normalize(light.Position - FragPos);
    vec3 diffuse = max(dot(Normal, lightDir), 0.0) * Diffuse * light.Color;
    // Specular
    vec3 halfwayDir = normalize(lightDir + viewDir);
    float spec = pow(max(dot(Normal, halfwayDir), 0.0), 8.0);
    vec3 specular = light.Color * spec;
    // Attenuation
    float dist = length(light.Position - FragPos);
    float attenuation = 1.0 / (1.0 + light.Linear * dist + light.Quadratic
    * dist * dist);
    diffuse *= attenuation;
    specular *= attenuation;
    lighting += diffuse + specular;

    FragColor = vec4(lighting, 1.0);
}
```

The only thing (besides changing it to view-space) we really changed compared to previous lighting implementations is the multiplication of the scene's ambient component by the `AmbientOcclusion` value. With a single point blue-ish light in the scene we'd get the following result:

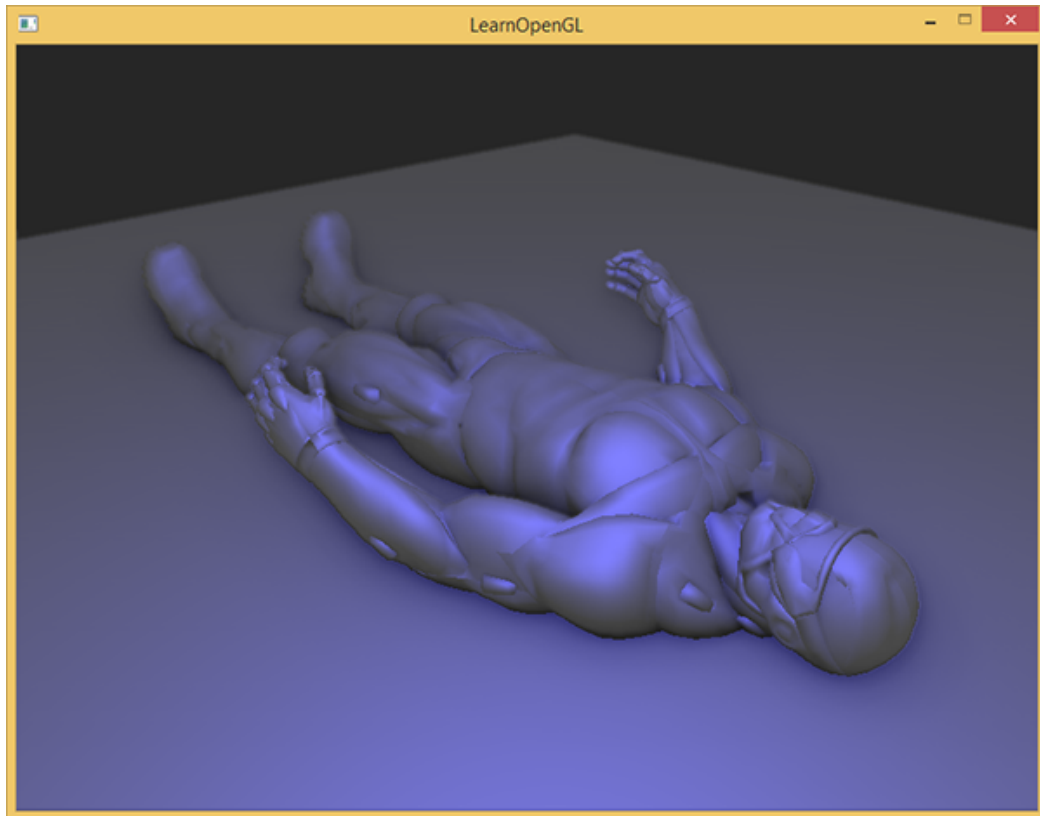

You can find the full source code [here](#) together with the following shaders:

- **geometry:** [vertex](#), [fragment](#).
- **SSAO:** [vertex](#), [fragment](#).
- **blur:** [vertex](#), [fragment](#).
- **lighting:** [vertex](#), [fragment](#).

Screen-space ambient occlusion is a highly customizable effect that relies heavily on tweaking its parameters based on the type of scene. There is no perfect combination of parameters for every type of scene; some scenes only work with a small radius, while some scenes require a larger radius and a larger sample count for it to look realistic. The current demo uses 64 samples which is a bit much, play around with a smaller kernel size and try to get good results.

Some parameters you can tweak (by using uniforms for example): kernel size, radius and/or size of noise kernel. You can also raise the final occlusion value to a user-defined power to increase its strength:

```
occlusion = 1.0 - (occlusion / kernelSize);  
FragColor = pow(occlusion, power);
```

Play around with different scenes and different parameters to appreciate the customizability of SSAO.

Even though SSAO is a subtle effect that isn't too clearly noticeable it adds a great deal of realism to properly lighted scenes and is definitely a technique you'd want to have in your toolkit.

42.7 Additional resources

- [SSAO Tutorial](#): excellent SSAO tutorial by John Chapman; a large portion of this tutorial's code and techniques are based of his article.
- [Know your SSAO artifacts](#): great article about improving SSAO specific artifacts.
- [SSAO With Depth Reconstruction](#): extension tutorial on top of SSAO from OGLDev about reconstructing position vectors from depth alone, saving us from storing the expensive position vectors in the G-buffer.

VM

In Practice

43	Text Rendering	458
44	2D Game	468
45	Breakout	469
46	Setting up	472
47	Rendering Sprites	476
48	Levels	482
49	Ball	490
50	Collision detection	494
51	Collision resolution	501
52	Particles	508
53	Postprocessing	514
54	Powerups	519
55	Audio	527
56	Render text	530
57	Final thoughts	539

A futuristic cityscape with a flying vehicle in the foreground. The vehicle is dark with blue lights and is flying towards the left. The city is filled with tall, thin buildings and is shrouded in a light mist or fog. The sky is a pale blue.

43. Text Rendering

At some stage of your graphics adventures you will want to draw text in OpenGL. Contrary to what you might expect, getting a simple string to render on screen is quite difficult with a low-level library like OpenGL. If you don't care about rendering more than 128 different characters, then it's probably not too difficult. Things are getting more difficult as soon as each character has a different width, height and margin. Based on where you live, you might also need more than 128 characters, and what if you want to express special symbols for like mathematical expressions or sheet music symbols, and what about rendering text from top to bottom? Once you think about all these complicated matters of text, it wouldn't surprise you that this probably doesn't belong in a low-level API like OpenGL.

Since there is no support for any text capabilities within OpenGL it is up to us to define a system for rendering text to the screen. Since there are no graphical primitives for text characters, we have to get creative. Some example techniques are: drawing letter shapes via `GL_LINES`, create 3D meshes of letters or render character textures to 2D quads in a 3D environment.

Most often developers choose to render character textures onto quads. Rendering these textured quads by itself shouldn't be too difficult, but getting the relevant character(s) onto a texture could prove challenging. In this tutorial we'll explore several methods and implement a more advanced, but flexible technique for rendering text using the FreeType library.

43.1 Classical text rendering: bitmap fonts

In the early days rendering text involved selecting a font (or create one yourself) you'd like for your application and extracting all relevant characters out of this font to paste them all within a single large texture. Such a texture, that we from now on call a **bitmap font**, contains all character symbols we want to use in predefined regions of the texture. These character symbols of the font are known as **glyphs**. Each glyph has a specific region of texture coordinates associated with them. Whenever you want to render a character, you select the corresponding glyph by rendering this section of the

from their source code or use one of their precompiled libraries if your target platform is listed. Be sure to link to `freetype.lib` and make sure your compiler knows where to find the header files.

Then be sure to include the appropriate headers:

```
#include <ft2build.h>
#include FT_FREETYPE_H
```

Due to how FreeType is developed (at least at the time of this writing), you cannot put their header files in a new directory; they should be located at the root of your include directories. Including FreeType like `#include <FreeType/ft2build.h>` will likely cause several header conflicts.

What FreeType does is load these TrueType fonts and for each glyph generates a bitmap image and calculates several metrics. We can extract these bitmap images for generating textures and position each character glyph appropriately using the loaded metrics.

To load a font, all we have to do is initialize the FreeType library and load the font as a `face` as FreeType likes to call it. Here we load the `arial.ttf` TrueType font file that was copied from the `Windows/Fonts` directory.

```
FT_Library ft;
if (FT_Init_FreeType(&ft))
    std::cout << "ERROR::FREETYPE: Could not init FreeType Library" << std::endl;

FT_Face face;
if (FT_New_Face(ft, "fonts/arial.ttf", 0, &face))
    std::cout << "ERROR::FREETYPE: Failed to load font" << std::endl;
```

Each of these FreeType functions returns a non-zero integer whenever an error occurred.

Once we've loaded the face, we should define the font size we'd like to extract from this face:

```
FT_Set_Pixel_Sizes(face, 0, 48);
```

The function sets the font's width and height parameters. Setting the width to 0 lets the face dynamically calculate the width based on the given height.

A FreeType face hosts a collection of glyphs. We can set one of those glyphs as the active glyph by calling `FT_Load_Char`. Here we choose to load the character glyph 'X':

```
if (FT_Load_Char(face, 'X', FT_LOAD_RENDER))
    std::cout << "ERROR::FREETYPE: Failed to load Glyph" << std::endl;
```

By setting `FT_LOAD_RENDER` as one of the loading flags, we tell FreeType to create an 8-bit grayscale bitmap image for us that we can access via `face->glyph->bitmap`.

Each of the glyphs we load with FreeType however do not have the same size (as we had with bitmap fonts). The bitmap image generated by FreeType is just large enough to contain the visible

part of a character. For example, the bitmap image of the dot character '.' is much smaller than the bitmap image of the character 'X'. For this reason, FreeType also loads several metrics that specify how large each character should be and how to properly position them. Below is an image by FreeType that shows all of the metrics it calculates for each character glyph.

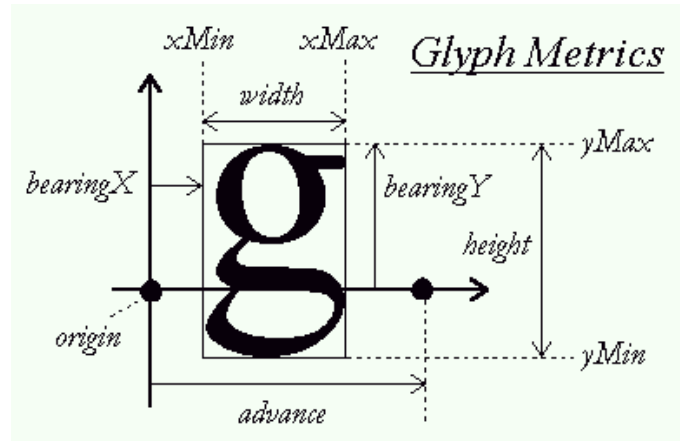

Each of the glyphs reside on a horizontal **baseline** (as depicted by the horizontal arrow) where some glyphs sit exactly on top of this baseline (like 'X') or some slightly below the baseline (like 'g' or 'p'). These metrics define exactly the offsets to properly position each glyph on the baseline, how large each glyph should be and how many pixels we need to advance to render the next glyph. Below is a small list of these properties we'll be needing.

- **width**: the width (in pixels) of the bitmap accessed via `face->glyph->bitmap.width`.
- **height**: the height (in pixels) of the bitmap accessed via `face->glyph->bitmap.rows`.
- **bearingX**: the horizontal bearing e.g. the horizontal position (in pixels) of the bitmap relative to the origin accessed via `face->glyph->bitmap_left`.
- **bearingY**: the vertical bearing e.g. the vertical position (in pixels) of the bitmap relative to the baseline accessed via `face->glyph->bitmap_top`.
- **advance**: the horizontal advance e.g. the horizontal distance (in 1/64th pixels) from the origin to the origin of the next glyph. Accessed via `face->glyph->advance.x`.

We could load a character glyph, retrieve its metrics and generate a texture each time we want to render a character to the screen, but it would be inefficient to do this each frame. We'd rather store the generated data somewhere in the application and query it whenever we want to render a character. We'll define a convenient `struct` that we'll store in a `map`.

```
struct Character {
    GLuint      TextureID; // ID handle of the glyph texture
    glm::ivec2  Size;      // Size of glyph
    glm::ivec2  Bearing;   // Offset from baseline to left/top of glyph
    GLuint      Advance;   // Offset to advance to next glyph
};

std::map<GLchar, Character> Characters;
```

For this tutorial we'll keep things simple by restricting ourselves to the first 128 characters of the ASCII character set. For each character, we generate a texture and store its relevant data into a `Character` struct that we add to the `Characters` map. This way, all data required to render each character is stored for later use.

```

glPixelStorei(GL_UNPACK_ALIGNMENT, 1); // Disable byte-alignment
restriction

for (GLubyte c = 0; c < 128; c++)
{
    // Load character glyph
    if (FT_Load_Char(face, c, FT_LOAD_RENDER))
    {
        std::cout << "ERROR::FREETYPE: Failed to load Glyph" << std::endl;
        continue;
    }
    // Generate texture
    GLuint texture;
    glGenTextures(1, &texture);
    glBindTexture(GL_TEXTURE_2D, texture);
    glTexImage2D(
        GL_TEXTURE_2D,
        0,
        GL_RED,
        face->glyph->bitmap.width,
        face->glyph->bitmap.rows,
        0,
        GL_RED,
        GL_UNSIGNED_BYTE,
        face->glyph->bitmap.buffer
    );
    // Set texture options
    glTexParameteri(GL_TEXTURE_2D, GL_TEXTURE_WRAP_S, GL_CLAMP_TO_EDGE);
    glTexParameteri(GL_TEXTURE_2D, GL_TEXTURE_WRAP_T, GL_CLAMP_TO_EDGE);
    glTexParameteri(GL_TEXTURE_2D, GL_TEXTURE_MIN_FILTER, GL_LINEAR);
    glTexParameteri(GL_TEXTURE_2D, GL_TEXTURE_MAG_FILTER, GL_LINEAR);
    // Now store character for later use
    Character character = {
        texture,
        glm::ivec2(face->glyph->bitmap.width, face->glyph->bitmap.rows),
        glm::ivec2(face->glyph->bitmap_left, face->glyph->bitmap_top),
        face->glyph->advance.x
    };
    Characters.insert(std::pair<GLchar, Character>(c, character));
}

```

Within the for loop we list over all the 128 characters of the ASCII set and retrieve their corresponding character glyphs. For each character, we generate a texture, set its options and store its metrics. What is interesting to note here is that we use `GL_RED` as the texture's `internalFormat` and `format` arguments. The bitmap generated from the glyph is a grayscale 8-bit image where each color is represented by a single byte. For this reason we'd like to store each byte of the bitmap buffer as a texture's color value. We accomplish this by creating a texture where each byte corresponds to the texture color's red component (first byte of its color vector). If we use a single byte to represent the colors of a texture we do need to take care of a restriction of OpenGL:

```
glPixelStorei(GL_UNPACK_ALIGNMENT, 1);
```

OpenGL requires that textures all have a 4-byte alignment e.g. their size is always a multiple of 4 bytes. Normally this won't be a problem since most textures have a width that is a multiple of 4 and/or use 4 bytes per pixel, but since we now only use a single byte per pixel they can have any possible width. By setting its `unpack alignment` equal to 1 we ensure there are no alignment issues (which could cause segmentation faults).

Also be sure to clear FreeType's resources once you're finished processing the glyphs:

```
FT_Done_Face(face);
FT_Done_FreeType(ft);
```

43.2.1 Shaders

To render the actual glyphs we'll be using the following vertex shader:

```
#version 330 core
layout (location = 0) in vec4 vertex; // <vec2 pos, vec2 tex>
out vec2 TexCoords;

uniform mat4 projection;

void main()
{
    gl_Position = projection * vec4(vertex.xy, 0.0, 1.0);
    TexCoords = vertex.zw;
}
```

We combine both the position and texture coordinate data into one `vec4`. The vertex shader multiplies the coordinates with a projection matrix and forwards the texture coordinates to the fragment shader:

```
#version 330 core
in vec2 TexCoords;
out vec4 color;

uniform sampler2D text;
uniform vec3 textColor;

void main()
{
    vec4 sampled = vec4(1.0, 1.0, 1.0, texture(text, TexCoords).r);
    color = vec4(textColor, 1.0) * sampled;
}
```

The fragment shader takes two uniforms: one is the mono-colored bitmap image of the glyph and the other is a color uniform for adjusting the text's final color. We first sample the color value of the bitmap texture. Because the texture's data is stored in just its red component, we sample the `r` component of the texture as the sampled alpha value. By varying the color's alpha value the resulting color will be transparent for all the glyph's background colors and non-transparent for the actual character pixels. We also multiply the RGB colors by the `textColor` uniform to vary the text color.

We do need to enable [blending](#) for this to work though:

```
glEnable(GL_BLEND);
glBlendFunc(GL_SRC_ALPHA, GL_ONE_MINUS_SRC_ALPHA);
```

For the projection matrix we'll be using an orthographic projection matrix. For rendering text we (usually) do not need perspective and using an orthographic projection matrix also allows us to specify all vertex coordinates in screen coordinates if we set it up as follows:

```
glm::mat4 projection = glm::ortho(0.0f, 800.0f, 0.0f, 600.0f);
```

We set the projection matrix's bottom parameter to `0.0f` and its top parameter equal to the window's height. The result is that we specify coordinates with `y` values ranging from the bottom part of the screen (`0.0f`) to the top part of the screen (`600.0f`). This means that the point `(0.0, 0.0)` now corresponds to the bottom-left corner.

Last up is creating a VBO and VAO for rendering the quads. For now we reserve enough memory when initiating the VBO so that we can later update the VBO's memory when rendering characters.

```
GLuint VAO, VBO;
glGenVertexArrays(1, &VAO);
glGenBuffers(1, &VBO);
glBindVertexArray(VAO);
glBindBuffer(GL_ARRAY_BUFFER, VBO);
glBufferData(GL_ARRAY_BUFFER, sizeof(GLfloat) * 6 * 4, NULL,
             GL_DYNAMIC_DRAW);
glEnableVertexAttribArray(0);
glVertexAttribPointer(0, 4, GL_FLOAT, GL_FALSE, 4 * sizeof(GLfloat), 0);
glBindBuffer(GL_ARRAY_BUFFER, 0);
glBindVertexArray(0);
```

The 2D quad requires 6 vertices of 4 floats each so we reserve `6 * 4` floats of memory. Because we'll be updating the content of the VBO's memory quite often we'll allocate the memory with `GL_DYNAMIC_DRAW`.

43.2.2 Render line of text

To render a character we extract the corresponding `Character` struct of the `Characters` map and calculate the quad's dimensions using the character's metrics. With the quad's calculated dimensions we dynamically generate a set of 6 vertices that we use to update the content of the memory managed by the VBO using `glBufferSubData`.

We create a function called `RenderText` that renders a string of characters:

```
void RenderText(Shader &s, std::string text, GLfloat x, GLfloat y, GLfloat
               scale, glm::vec3 color)
{
    // Activate corresponding render state
    s.Use();
    glUniform3f(glGetUniformLocation(s.Program, "textColor"), color.x,
               color.y, color.z);
    glActiveTexture(GL_TEXTURE0);
    glBindVertexArray(VAO);

    // Iterate through all characters
    std::string::const_iterator c;
    for (c = text.begin(); c != text.end(); c++)
    {
        Character ch = Characters[*c];

        GLfloat xpos = x + ch.Bearing.x * scale;
        GLfloat ypos = y - (ch.Size.y - ch.Bearing.y) * scale;
```

```

GLfloat w = ch.Size.x * scale;
GLfloat h = ch.Size.y * scale;
// Update VBO for each character
GLfloat vertices[6][4] = {
    { xpos,      ypos + h, 0.0, 0.0 },
    { xpos,      ypos,     0.0, 1.0 },
    { xpos + w, ypos,     1.0, 1.0 },

    { xpos,      ypos + h, 0.0, 0.0 },
    { xpos + w, ypos,     1.0, 1.0 },
    { xpos + w, ypos + h, 1.0, 0.0 }
};
// Render glyph texture over quad
glBindTexture(GL_TEXTURE_2D, ch.textureID);
// Update content of VBO memory
glBindBuffer(GL_ARRAY_BUFFER, VBO);
glBufferSubData(GL_ARRAY_BUFFER, 0, sizeof(vertices), vertices);
glBindBuffer(GL_ARRAY_BUFFER, 0);
// Render quad
glDrawArrays(GL_TRIANGLES, 0, 6);
// Now advance cursors for next glyph (note that advance is number
of 1/64 pixels)
x += (ch.Advance >> 6) * scale; // Bitshift by 6 to get value in
pixels (2^6 = 64)
}
glBindVertexArray(0);
glBindTexture(GL_TEXTURE_2D, 0);
}

```

The content of the function should be relatively self-explanatory: we first calculate the origin position of the quad (as `xpos` and `ypos`) and the quad's size (as `w` and `h`) and generate a set of 6 vertices to form the 2D quad; note that we scale each metric by `scale`. We then update the content of the VBO and render the quad.

The following line of code requires some extra attention though:

```
GLfloat ypos = y - (ch.Size.y - ch.Bearing.y);
```

Some characters (like 'p' or 'g') are rendered slightly below the baseline so the quad should also be positioned slightly below `RenderText`'s `y` value. The exact amount we need to offset `ypos` below the baseline can be figured out from the glyph metrics:

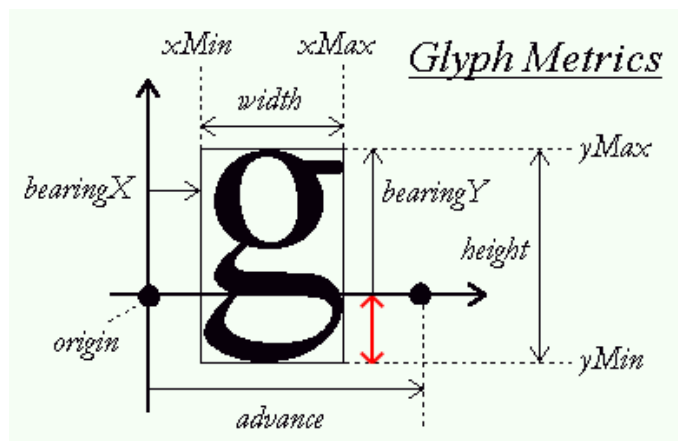

To calculate this distance e.g. offset we need to figure out the distance a glyph extends below the baseline; this distance is indicated by the red arrow. As you can see from the glyph metrics we can calculate the length of this vector by subtracting `bearingY` from the glyph's (bitmap) height. This value is then 0.0 for characters that rest on the baseline (like 'X') and positive for characters that reside slightly below the baseline (like 'g' or 'j').

If you did everything correct you should now be able to successfully render strings of text with the following statements:

```
RenderText(shader, "This is sample text", 25.0f, 25.0f, 1.0f, glm::vec3  
           (0.5, 0.8f, 0.2f));  
RenderText(shader, "(C) LearnOpenGL.com", 540.0f, 570.0f, 0.5f, glm::vec3  
           (0.3, 0.7f, 0.9f));
```

This should then look similar to the following image:



You can find the code of this example [here](#).

To give you a feel of how we calculated the quad's vertices we can disable blending to see what the actual rendered quads look like:

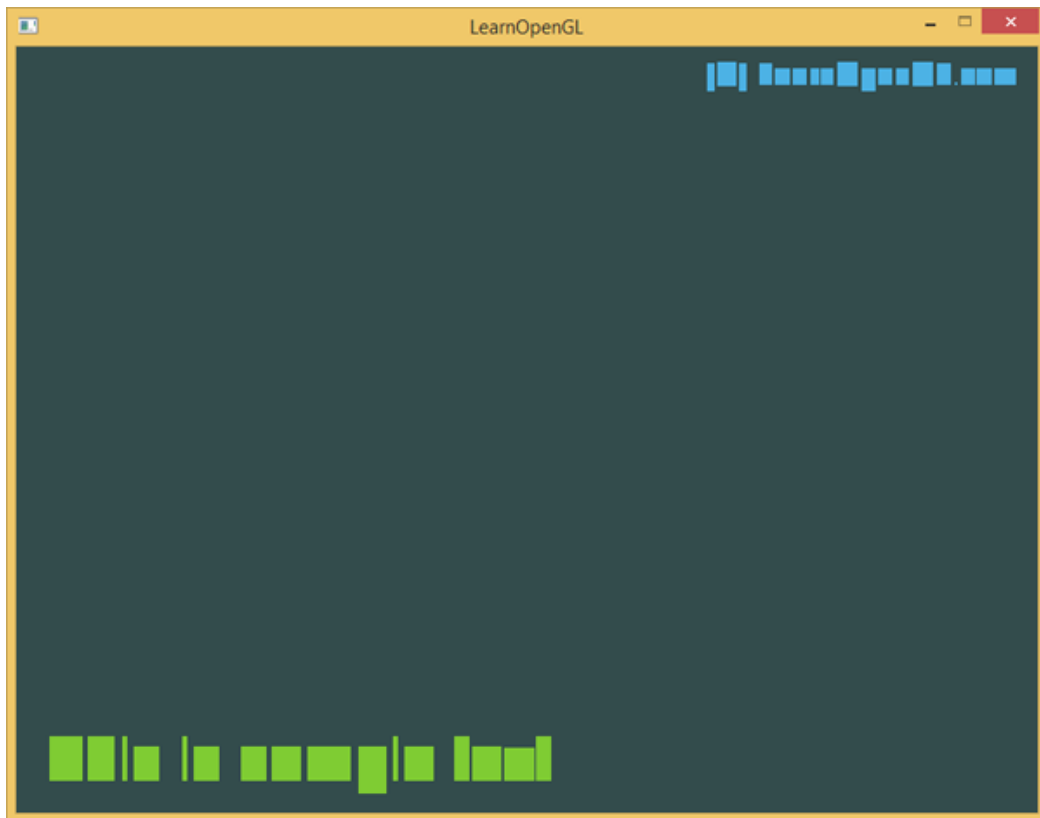

Here you can clearly see most quads resting on the (imaginary) baseline while the quads that corresponds to glyphs like 'p' or '(' are shifted downwards.

43.3 Going further

This tutorial demonstrated a text rendering technique with TrueType fonts using the FreeType library. The approach is flexible, scalable and works with many character encodings. However, it might be overkill for your application and performance-wise bitmap fonts might be preferable. You could of course combine the two approaches by dynamically generating a bitmap font featuring all characters glyphs as loaded with FreeType. This saves the renderer from a significant amount of texture switches and based on how tightly each glyph is packed could save quite some performance.

Another issue with FreeType fonts is that the glyph textures are stored with a fixed font size so a significant amount of scaling might be required that will introduce jagged edges. Furthermore, rotations applied to the glyphs will cause them to appear blurry. This can be mitigated by, instead of storing the actual rasterized pixel color, storing the distance to the closest glyph outline per pixel. This technique is called [signed distance fields](#) and Valve published a [paper](#) a few years ago about their implementation of this technique which works surprisingly well for 3D rendering applications.

A futuristic cityscape with a flying vehicle. The scene is set in a dense, vertical city with many tall, thin buildings. A dark, sleek flying vehicle with blue lights is in the foreground, flying towards the right. The background is a hazy, golden-brown sky, suggesting a sunset or sunrise. The overall atmosphere is futuristic and cinematic.

44. 2D Game

The following chapters discuss the step-by-step development of a simple Breakout game in OpenGL as to give you some sense how to actually use OpenGL to create something meaningful instead of just a few relatively simple tech demos.

A futuristic cityscape with a flying vehicle. The image shows a dense collection of tall, slender skyscrapers under a hazy sky. In the foreground, a dark, sleek flying vehicle with blue glowing lights is positioned on the left side, appearing to fly towards the right. The overall scene is rendered in a cinematic, slightly desaturated style.

45. Breakout

Over these tutorials we learned a fair share about OpenGL's inner workings and how we can use them to create fancy graphics. However, aside from a few tech demos, we haven't really created a practical application with OpenGL. This is the introduction of a larger tutorial series about creating a relatively simple 2D game using OpenGL. The tutorial series will demonstrate how we can use OpenGL in a larger, more complicated, setting. Note that the series does not necessarily introduce new OpenGL concepts but more or less show how we can apply these concepts to a larger whole.

Because we rather keep things simple we're going to base our 2D game on an already existing 2D arcade game. Introducing [Breakout](#), a classic 2D game released in 1976 on the Atari 2600 console. Breakout requires the player, who controls a small horizontal paddle, to destroy all the bricks by bouncing a small ball against each brick without allowing the ball to reach the bottom edge. Once the player destroyed all bricks, he completes the game.

Below we can see how Breakout originally looked on the Atari 2600:



The game has the following mechanics:

- A small paddle is controlled by the player and can only move within the bounds of the screen; either left or right.
- The ball travels across the screen and each collision results in the ball changing its direction based on where it hit; this applies to the screen bounds, the bricks and the paddle.
- If the ball reaches the bottom edge of the screen, the player is either game over or loses a life.
- As soon as a brick touches the ball, it is destroyed.
- The player wins as soon as all bricks are destroyed.
- The direction of the ball can be manipulated by how far the ball bounces from the paddle's center.

Because from time to time the ball might find a small gap reaching the area above the brick wall, it will continue to bounce up and forth between the top edge of the level and the top edge of the brick layer. The ball keeps this up, until it eventually finds a gap again. This is logically where the game obtained its name from, since the ball has to *break out*.

45.1 OpenGL Breakout

We're going to take this classic arcade game as the basis of a 2D game that we'll completely implement with OpenGL. This version of Breakout will run on the graphics card which gives us the ability to enhance the classical Breakout game with some nice extra features.

Aside from the classical mechanics, our version of Breakout will feature:

- Best graphics you've ever seen
- Particles
- Advanced text rendering
- PowerUps

- Postprocessing effects
- Multiple (customizable) levels

To get you excited you can see what the game will look like below after you've finished the tutorial series:

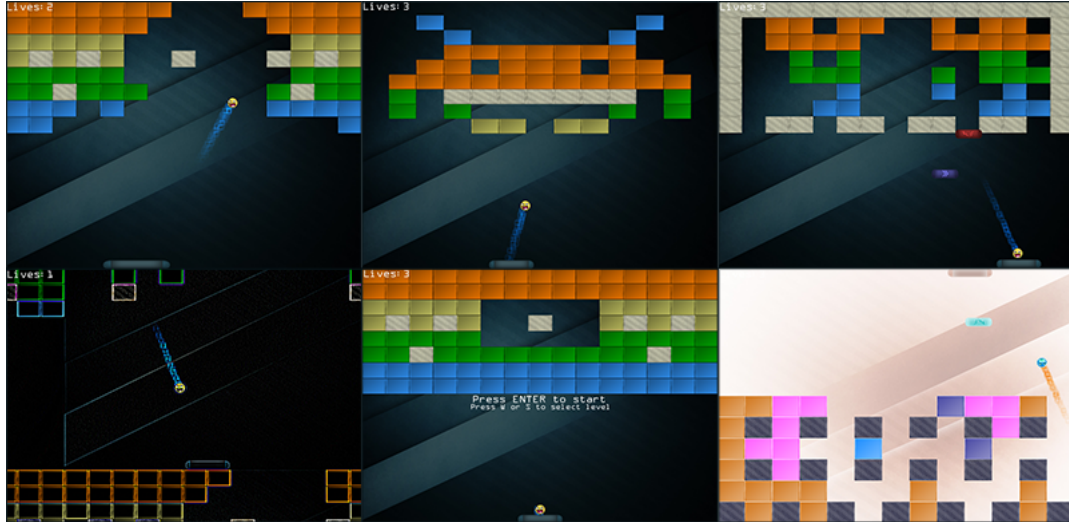

These tutorials will combine a large number of concepts as discussed in previous tutorials and demonstrate how they can work together as a whole. Therefore, it is important to have at least finished the [Getting started](#) section before working your way through these tutorials.

Also, several tutorials will require concepts from other tutorials (for example [Framebuffers](#) from the [Advanced OpenGL](#) section) so where necessary, the required tutorials are listed.

If you believe you're ready to get your hands dirty then move on to the [next tutorial](#).



46. Setting up

Before we get started with the actual game mechanics we first need to set up a simple framework for the game to reside in. The game will use several third party libraries of which most of them were introduced in the earlier tutorials. Wherever a new library is required, it will be properly introduced.

First, we define a so called **uber** game class that contains all relevant render and gameplay code. The idea of such a game class is that it (sort of) organizes your game code while also decoupling all windowing code from the game. This way, you could use the same class in a completely different windowing library (like SDL or SFML for example) without much effort.

There are thousands of ways of trying to abstract and generalize game/graphics code into classes and objects. What you will see in this tutorials is just one approach to solve these problems. If you feel there is a better approach, try to come up with your own improvement of the implementation.

The game class hosts an initialization function, an update function, a function to process input and a render function:

```
class Game
{
    public:
        // Game state
        GameState State;
        GLboolean Keys[1024];
        GLuint    Width, Height;
        // Constructor/Destructor
        Game(GLuint width, GLuint height);
        ~Game();
        // Initialize game state (load all shaders/textures/levels)
```



```

void Init();
// GameLoop
void ProcessInput(GLfloat dt);
void Update(GLfloat dt);
void Render();
};

```

The class hosts what you might expect from a game class. We initialize the game by giving a width and height (corresponding to the resolution you want to play the game in) and use the `Init` function to load shaders, textures and initialize all gameplay state. We can process the input as stored within the `Keys` array by calling `ProcessInput` and update all gameplay events (like player/ball movement) in the `Update` function. Last, we can render the game by calling `Render`. Note that we split the movement logic from the render logic.

The `Game` class also hosts a variable called `State` which is of type `GameState` as defined below:

```

// Represents the current state of the game
enum GameState {
    GAME_ACTIVE,
    GAME_MENU,
    GAME_WIN
};

```

This allows us to keep track of what state the game is currently in. This way we can decide to render and/or process different items based on the current state of the game (we probably render and process different items when we're in the game's menu for example).

As of now, the functions of the game class are completely empty since we have yet to write the actual game code, but here are the `Game` class's [header](#) and [code](#) file.

46.1 Utility

Since we're creating a large application we'll frequently have to re-use several OpenGL concepts, like textures and shaders. It thus makes sense to create a more easy-to-use interface for these two items as similarly done in one of the earlier tutorials where we created a shader class.

A shader class is defined that generates a compiled shader (or generates error messages if it fails) from two or three strings (if a geometry shader is present). The shader class also contains a lot of useful utility functions to quickly set uniform values. A texture class is also defined that generates a 2D texture image (based on its properties) from a byte array and a given width and height. Again, the texture class also hosts utility functions.

We won't delve into the details of the classes since by now you should easily understand how they work. For this reason you can find the header and code files, fully commented, below:

- **Shader:** [header](#), [code](#).
- **Texture:** [header](#), [code](#).

Note that the current texture class is solely designed for 2D textures only, but could easily be extended for alternative texture types.

46.2 Resource management

While the shader and texture classes function great by themselves, they do require either a byte array or several strings to initialize them. We could easily embed file loading code within the classes themselves, but this slightly violates the [single responsibility principle](#) in that the classes should only focus on either textures or shaders respectively and not necessarily their file-loading mechanics.

For this reason it is often considered a more organized approach to create a single entity designed for loading game-related resources called a [resource manager](#). There are several approaches to creating a resource manager; for this tutorial we chose to use a singleton static resource manager that is (due to its static nature) always available throughout the project hosting all loaded resources and its relevant loading functionality.

Using a singleton class with static functionality has several advantages and disadvantages with its disadvantages mostly being losing OOP properties and losing control over construction/destruction. However, for relative small projects like these it is easy to work with.

Like the other class files, the resource manager is listed below:

- **Resource Manager:** [header](#), [code](#).

Using the resource manager we can easily load shaders into the program like:

```
Shader shader = ResourceManager::LoadShader("vertex.vs", "fragment.vs",
    nullptr, "test");
// then use it
shader.Use();
// or
ResourceManager::GetShader("test").Use();
```

The defined [Game](#) class together with the resource manager and the easily manageable [Shader](#) and [Texture2D](#) classes form the basis for the next tutorials as we'll be extensively using these classes to implement the Breakout game.

46.3 Program

We still need a window for the game and set some initial OpenGL state. We make use of OpenGL's [face-culling](#) functionality and of its [blending](#) functionality. We do not use depth testing; since the game is entirely in 2D, all vertices are defined with the same z-values, so enabling depth testing would be of no use and likely cause z-fighting.

The startup code of the Breakout game is relatively simple: we create a window with GLFW, register a few callback functions, create the Game object and propagate all relevant functionality to the game class. The code is given below:

- **Program:** [code](#).

Running the code should give you the following output:

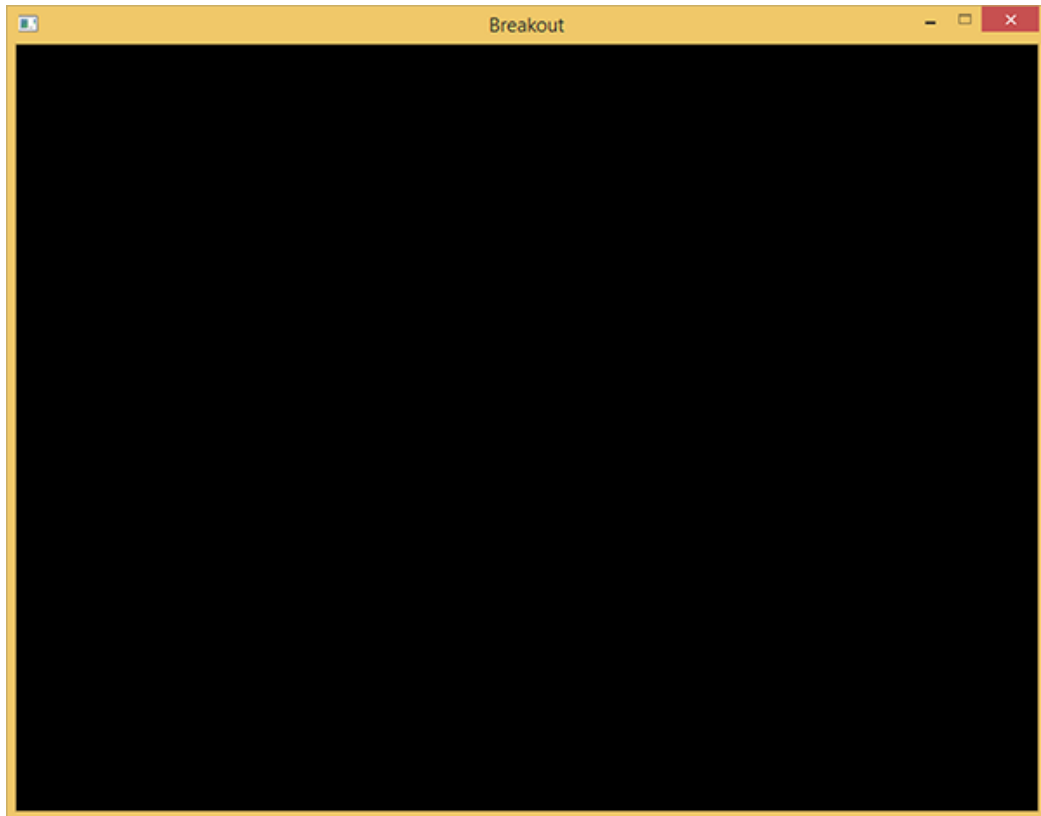

By now we have a solid framework for the upcoming tutorials; we'll be continuously extending the game class to host new functionality. Hop over to the [next](#) tutorial once you're ready.

A futuristic cityscape with a flying vehicle in the foreground. The city is filled with tall, slender buildings and a hazy atmosphere. A dark, sleek flying vehicle with blue lights is positioned in the lower-left foreground, flying towards the right. The background is a dense forest of tall, thin buildings that fade into a hazy, blue-tinted sky.

47. Rendering Sprites

To bring some life to the currently black abyss of our game world, we will render sprites to fill the void. A [sprite](#) has many definitions, but basically it is a 2D image used together with some data to position it in a larger world like a position, a rotation angle and a two dimensional size. Basically, sprites are the render-able image/texture objects we use in a 2D game.

We can, just like we did with most of the tutorials, create some 2D shape out of vertex data, pass all data to the GPU and transform it all by hand. However, in a larger application like this we rather have some abstractions on rendering 2D shapes. If we were to manually define these shapes and transformations for each object, it'll quickly get messy.

In this tutorial we'll define a rendering class that allows us to render a large amount of sprites with a minimal amount of code. This way, we're abstracting the gameplay code from the gritty OpenGL rendering code as is commonly done in larger projects. First we have to set up a proper projection matrix though.

47.1 2D projection matrix

We know from the [coordinate systems](#) tutorial that the projection matrix converts all view-space coordinates to normalized device coordinates. By generating the appropriate projection matrix we can work with different coordinates, that are likely easier to work with compared to directly specifying all coordinates as normalized device coordinates.

We don't need any perspective applied to the coordinates since the game is entirely in 2D so an orthographic projection matrix would suit the rendering quite well. Because an orthographic projection matrix almost directly transforms all coordinates to clip space we can choose to specify the world coordinates as screen coordinates by defining the projection matrix as follows:

```
glm::mat4 projection = glm::ortho(0.0f, 800.0f, 600.0f, 0.0f, -1.0f, 1.0f);
```

The first four arguments specify in order the left, right, bottom and top part of the projection frustum. This projection matrix transforms all x coordinates between 0 and 800 to -1 and 1 and all y coordinates between 0 and 600 to -1 and 1 . Here we specified that the top of the frustum has an y coordinate of 0 while the bottom has an y coordinate of 600. The result is that the top-left coordinate of the scene will be at $(0, 0)$ and the bottom-right part of the screen is at coordinate $(800, 600)$ just like screen coordinates; the view-space coordinates directly correspond to the resulting pixel coordinates.

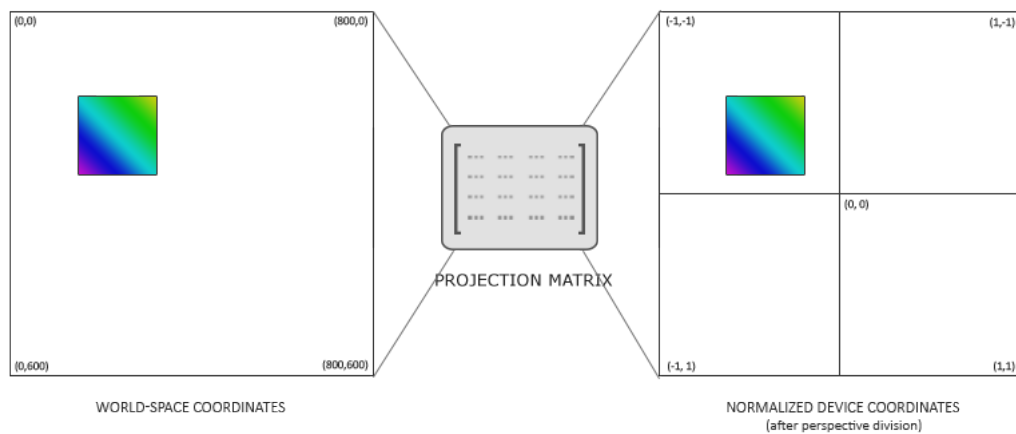

This allows us to specify all vertex coordinates equal to the pixel coordinates they end up in on the screen, which is rather intuitive for 2D games.

47.2 Rendering sprites

Rendering an actual sprite shouldn't be too complicated. We create a textured quad that we can transform with a model matrix after which we project it using the previously defined orthographic projection matrix.

Since Breakout is a static game, there is no need for a view/camera matrix so using the projection matrix we can directly transform the world-space coordinates to clip-space coordinates.

To transform a sprite we use the following vertex shader:

```
#version 330 core
layout (location = 0) in vec4 vertex; // <vec2 position, vec2 texCoords>

out vec2 TexCoords;

uniform mat4 model;
uniform mat4 projection;

void main()
{
```

```

TexCoords = vertex.zw;
gl_Position = projection * model * vec4(vertex.xy, 0.0, 1.0);
}

```

Note that we store both the position and texture-coordinate data in a single `vec4` variable. Because both the position and texture coordinates contain two floats we can combine them into a single vertex attribute.

The fragment shader is relatively straightforward as well. We take a texture and a color vector that both affect the final color of the fragment. By also having a uniform color vector we can easily change the color of sprites from the game-code.

```

#version 330 core
in vec2 TexCoords;
out vec4 color;

uniform sampler2D image;
uniform vec3 spriteColor;

void main()
{
    color = vec4(spriteColor, 1.0) * texture(image, TexCoords);
}

```

To make the rendering of sprites more organized we defined a `SpriteRenderer` class that is able to render a sprite with just a single function. Its definition is as follows:

```

class SpriteRenderer
{
public:
    SpriteRenderer(Shader &shader);
    ~SpriteRenderer();

    void DrawSprite(Texture2D &texture, glm::vec2 position,
        glm::vec2 size = glm::vec2(10, 10), GLfloat rotate = 0.0f,
        glm::vec3 color = glm::vec3(1.0f));
private:
    Shader shader;
    GLuint quadVAO;

    void initRenderData();
};

```

The `SpriteRenderer` class hosts a shader object, a single vertex array object and a rendering and initialization function. Its constructor takes a shader object that it uses for all future rendering.

47.2.1 Initialization

First, let's delve into the `initRenderData` function that configures the `quadVAO`:

```

void SpriteRenderer::initRenderData()
{
    // Configure VAO/VBO
    GLuint VBO;
    GLfloat vertices[] = {

```

```

        // Pos      // Tex
        0.0f, 1.0f, 0.0f, 1.0f,
        1.0f, 0.0f, 1.0f, 0.0f,
        0.0f, 0.0f, 0.0f, 0.0f,

        0.0f, 1.0f, 0.0f, 1.0f,
        1.0f, 1.0f, 1.0f, 1.0f,
        1.0f, 0.0f, 1.0f, 0.0f
    };

    glGenVertexArrays(1, &this->quadVAO);
    glGenBuffers(1, &VBO);

    glBindBuffer(GL_ARRAY_BUFFER, VBO);
    glBufferData(GL_ARRAY_BUFFER, sizeof(vertices), vertices,
        GL_STATIC_DRAW);

    glBindVertexArray(this->quadVAO);
    glEnableVertexAttribArray(0);
    glVertexAttribPointer(0, 4, GL_FLOAT, GL_FALSE, 4 * sizeof(GLfloat), (
        GLvoid*)0);
    glBindBuffer(GL_ARRAY_BUFFER, 0);
    glBindVertexArray(0);
}

```

Here we first define a set of vertices with the (0, 0) coordinate being the top-left corner of the quad. This means that when we apply translation or scaling transformations onto the quad, they're transformed from the top-left position of the quad. This is commonly accepted in 2D graphics and/or GUI systems where elements' positions correspond to the top-left corner of the elements.

Next we simply sent the vertices to the GPU and configure the vertex attributes, which in this case is a single vertex attribute. We only have to define a single VAO for the sprite renderer since all sprites share the same vertex data.

47.2.2 Rendering

Rendering sprites is not too difficult; we use the sprite renderer's shader, configure a model matrix and set the relevant uniforms. What is important here is the order of transformations:

```

void SpriteRenderer::DrawSprite(Texture2D &texture, glm::vec2 position,
    glm::vec2 size, GLfloat rotate, glm::vec3 color)
{
    // Prepare transformations
    this->shader.Use();
    glm::mat4 model;
    model = glm::translate(model, glm::vec3(position, 0.0f));

    model = glm::translate(model, glm::vec3(0.5f * size.x, 0.5f * size.y,
        0.0f));
    model = glm::rotate(model, rotate, glm::vec3(0.0f, 0.0f, 1.0f));
    model = glm::translate(model, glm::vec3(-0.5f * size.x, -0.5f * size.y,
        0.0f));

    model = glm::scale(model, glm::vec3(size, 1.0f));

    glActiveTexture(GL_TEXTURE0);
    texture.Bind();
}

```

```

glBindVertexArray(this->quadVAO);
glDrawArrays(GL_TRIANGLES, 0, 6);
glBindVertexArray(0);
}

```

When trying to position objects somewhere in a scene with rotation and scaling transformations it is advised to first scale, then rotate and finally translate the object. Because multiplying matrices occurs from right to left we transform the matrix in reverse order: translate, rotate and then scale.

The rotation transformation might seem slightly daunting at first. We know from the [transformations](#) tutorial that rotations always revolve around the origin $(0, 0)$. Because we specified the quad's vertices with $(0, 0)$ as the top-left coordinate of the quad, all rotations will rotate around this point of $(0, 0)$. Basically, the **origin of rotation** is at the top-left of the quad which produces undesirable results. What we want to do, is move the origin of rotation to the center of the quad so the quad neatly rotates around this origin, instead of rotating around the top-left of the quad. We solve this by translating the quad so its center is at coordinate $(0, 0)$ before rotating.

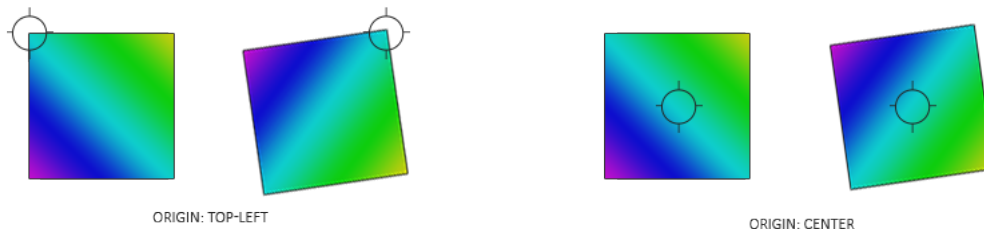

Since we first scale the quad, we have to take the size of the sprite into account when translating to the sprite's center (which is why we multiply with the sprite's `size` vector). Once the rotation transformation is applied, we reverse the previous translation.

Combining all these transformations we can position, scale and rotate each sprite in any way we like. Below you can find the complete source code of the sprite renderer:

- **SpriteRenderer:** [header](#), [code](#)

47.3 Hello sprite

With the `SpriteRenderer` class we finally have the ability to render actual images to the screen! Let's initialize one within the game code and load our favorite [texture](#) while we're at it:

```

SpriteRenderer *Renderer;

void Game::Init()
{
    // Load shaders
    ResourceManager::LoadShader("shaders/sprite.vs", "shaders/sprite.frag",
        nullptr, "sprite");
    // Configure shaders
    glm::mat4 projection = glm::ortho(0.0f, static_cast<GLfloat>(this->
        Width),
        static_cast<GLfloat>(this->Height), 0.0f, -1.0f, 1.0f);
    ResourceManager::GetShader("sprite").Use().SetInteger("image", 0);
}

```

```
ResourceManager::GetShader("sprite").SetMatrix4("projection",
projection);
// Set render-specific controls
Renderer = new SpriteRenderer(ResourceManager::GetShader("sprite"));
// Load textures
ResourceManager::LoadTexture("textures/awesomeface.png", GL_TRUE, "face
");
}
```

Then within the render function we can render our beloved mascot to see if everything works as it should:

```
void Game::Render()
{
    Renderer->DrawSprite(ResourceManager::GetTexture("face"),
        glm::vec2(200, 200), glm::vec2(300, 400), 45.0f, glm::vec3(0.0f,
1.0f, 0.0f));
}
```

Here we position the sprite somewhat close to the center of the screen with its height being slightly larger than its width. We also rotate it by 45 degrees and give it a green color. Note that the position we give the sprite is equal to the top-left vertex of the sprite's quad.

If you did everything right you should get the following output:



You can find the updated game class's source code [here](#).

Now that we got the rendering systems working, we can put it to good use in the [next](#) tutorial where we'll work on building the game's levels.



48. Levels

Breakout is unfortunately not just about a single happy green face, but contains complete levels with a lot of playfully colored bricks. We want these levels to be flexible such that they can support any number of rows and/or columns, we want the levels to have solid bricks (that cannot be destroyed), we want the levels to support multiple brick colors and we want them to be stored externally in (text) files.

In this tutorial we'll briefly walk through the code of a game level object that is used to manage a large amount of bricks. We first have to define what an actual **brick** is though.

We create a component called a **game object** that acts as the base representation of an object inside the game. Such a game object holds state data like its position, size and velocity. It holds a color, a rotation component, whether it is solid and/or destroyed and it also stores a `Texture2D` variable as its sprite.

Each object in the game is represented as a `GameObject` or a derivative of this class. You can find the code of the `GameObject` class below:

- **GameObject:** [header](#), [code](#)

A level in Breakout basically consists entirely of bricks so we can represent a level by exactly that: a collection of bricks. Because a brick requires almost all of the same state as a game object we're going to represent each brick of the level as a `GameObject`. The layout of the `GameLevel` class then looks as follows:

```
class GameLevel
{
public:
    std::vector<GameObject> Bricks;

    GameLevel() { }
```



```

// Loads level from file
void Load(const GLchar *file, GLuint levelWidth, GLuint levelHeight);
// Render level
void Draw(SpriteRenderer &renderer);
// Check if the level is completed (all non-solid tiles are destroyed)
GLboolean IsCompleted();
private:
// Initialize level from tile data
void init(std::vector<std::vector<GLuint>> tileData, GLuint levelWidth,
          GLuint levelHeight);
};

```

Since a level is loaded from an external (text) file we need to propose some kind of level structure. Below is an example of what a game level might look like in a text file:

```

1 1 1 1 1 1
2 2 0 0 2 2
3 3 4 4 3 3

```

Here a level is stored in a matrix-like structure where each number represents a type of brick, each one separated by a space. Within the level code we could assign what each number represents. We have chosen the following representation:

- A number of 0: no brick, an empty space within the level.
- A number of 1: a solid brick, a brick that cannot be destroyed.
- A number higher than 1: a destroyable brick; each number only differs in color.

The example level listed above would, after being processed by `GameLevel`, look like this:

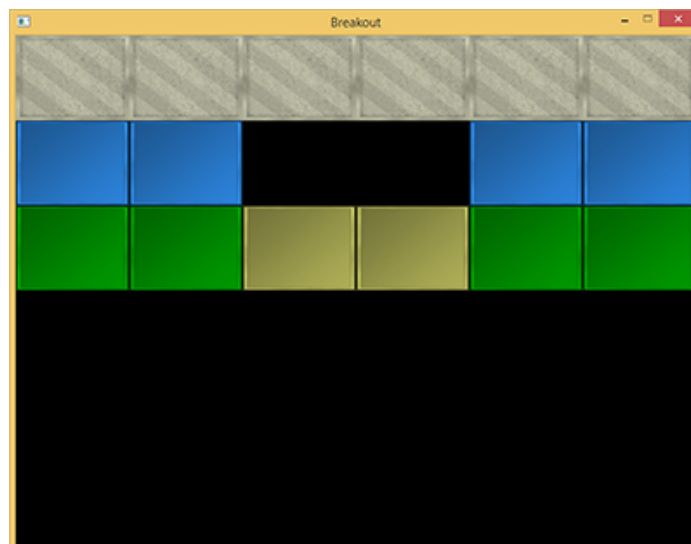

The `GameLevel` class uses two functions to generate a level from file. It first loads all the numbers in a two-dimensional vector within its `Load` function that then processes these numbers (to create all game objects) in its `init` function.

```

void GameLevel::Load(const GLchar *file, GLuint levelWidth, GLuint
                    levelHeight)
{
    // Clear old data
    this->Bricks.clear();
}

```

```

// Load from file
GLuint tileCode;
GameLevel level;
std::string line;
std::ifstream fstream(file);
std::vector<std::vector<GLuint>> tileData;
if (fstream)
{
    while (std::getline(fstream, line)) // Read each line from level
file
    {
        std::istringstream sstream(line);
        std::vector<GLuint> row;
        while (sstream >> tileCode) // Read each word separated by
spaces
            row.push_back(tileCode);
        tileData.push_back(row);
    }
    if (tileData.size() > 0)
        this->init(tileData, levelWidth, levelHeight);
}
}

```

The loaded `tileData` is then passed to the game level's `init` function:

```

void GameLevel::init(std::vector<std::vector<GLuint>> tileData, GLuint
lvlWidth, GLuint lvlHeight)
{
    // Calculate dimensions
    GLuint height = tileData.size();
    GLuint width = tileData[0].size();
    GLfloat unit_width = lvlWidth / static_cast<GLfloat>(width);
    GLfloat unit_height = lvlHeight / height;
    // Initialize level tiles based on tileData
    for (GLuint y = 0; y < height; ++y)
    {
        for (GLuint x = 0; x < width; ++x)
        {
            // Check block type from level data (2D level array)
            if (tileData[y][x] == 1) // Solid
            {
                glm::vec2 pos(unit_width * x, unit_height * y);
                glm::vec2 size(unit_width, unit_height);
                GameObject obj(pos, size,
                    ResourceManager::GetTexture("block_solid"),
                    glm::vec3(0.8f, 0.8f, 0.7f)
                );
                obj.IsSolid = GL_TRUE;
                this->Bricks.push_back(obj);
            }
            else if (tileData[y][x] > 1)
            {
                glm::vec3 color = glm::vec3(1.0f); // original: white
                if (tileData[y][x] == 2)
                    color = glm::vec3(0.2f, 0.6f, 1.0f);
                else if (tileData[y][x] == 3)
                    color = glm::vec3(0.0f, 0.7f, 0.0f);
                else if (tileData[y][x] == 4)
                    color = glm::vec3(0.8f, 0.8f, 0.4f);
                else if (tileData[y][x] == 5)

```

```

        color = glm::vec3(1.0f, 0.5f, 0.0f);

        glm::vec2 pos(unit_width * x, unit_height * y);
        glm::vec2 size(unit_width, unit_height);
        this->Bricks.push_back(
            GameObject(pos, size, ResourceManager::GetTexture("
block"), color)
        );
    }
}
}
}
}

```

The `init` function iterates through each of the loaded numbers and adds a `GameObject` to the level's `Bricks` vector based on the processed number. The size of each brick is automatically calculated (`unit_width` and `unit_height`) based on the total number of bricks so that each brick perfectly fits within the screen bounds.

Here we load the game objects with two new textures, namely a `block` texture and a `solid block` texture.

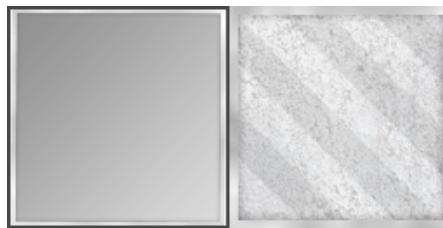

A nice little trick here is that these textures are completely in gray-scale. The effect is that we can neatly manipulate their colors within the game-code by multiplying their grayscale colors with a defined color vector; exactly as we did within the `SpriteRenderer`. This way, customizing the appearance of their colors doesn't look too weird or unbalanced.

The `GameLevel` class also houses a few other functions like rendering all non-destroyed bricks or validating if all non-solid bricks are destroyed. You can find the source code of the `GameLevel` class below:

- **GameLevel:** [header](#), [code](#)

The game level class gives us a lot of flexibility since any amount of rows and columns are supported and a user could easily create his/her own levels by modifying the level files.

48.1 Within the game

We would like to support multiple levels in the Breakout game so we'll have to extend the game class a little by adding a vector that holds variables of type `GameLevel`. We'll also store the currently active level while we're at it:

```

class Game
{
    [...]
    std::vector<GameLevel> Levels;
    GLuint Level;
}

```

```
[...]
};
```

This tutorial version of the Breakout game features a total of 4 levels:

- [Standard](#)
- [A few small gaps](#)
- [Space invader](#)
- [Bounce galore](#)

Each of the textures and levels are then initialized within the game class's `Init` function:

```
void Game::Init()
{
    [...]
    // Load textures
    ResourceManager::LoadTexture("textures/background.jpg", GL_FALSE, "
background");
    ResourceManager::LoadTexture("textures/awesomeface.png", GL_TRUE, "face
");
    ResourceManager::LoadTexture("textures/block.png", GL_FALSE, "block");
    ResourceManager::LoadTexture("textures/block_solid.png", GL_FALSE, "
block_solid");
    // Load levels
    GameLevel one; one.Load("levels/one.lvl", this->Width, this->Height *
0.5);
    GameLevel two; two.Load("levels/two.lvl", this->Width, this->Height *
0.5);
    GameLevel three; three.Load("levels/three.lvl", this->Width, this->
Height * 0.5);
    GameLevel four; four.Load("levels/four.lvl", this->Width, this->Height
* 0.5);
    this->Levels.push_back(one);
    this->Levels.push_back(two);
    this->Levels.push_back(three);
    this->Levels.push_back(four);
    this->Level = 1;
}
```

Now all that is left to do is actually render the level which we accomplish by calling the currently active level's `Draw` function that in turn calls each `GameObject`'s `Draw` function using the given sprite renderer. Aside from the level, we'll also render the scene with a nice [background image](#) (courtesy of Tenha):

```
void Game::Render()
{
    if(this->State == GAME_ACTIVE)
    {
        // Draw background
        Renderer->DrawSprite(ResourceManager::GetTexture("background"),
glm::vec2(0, 0), glm::vec2(this->Width, this->Height), 0.0f
);
        // Draw level
        this->Levels[this->Level].Draw(*Renderer);
    }
}
```

The result is then a nicely rendered level that really starts to make the game feel more alive:

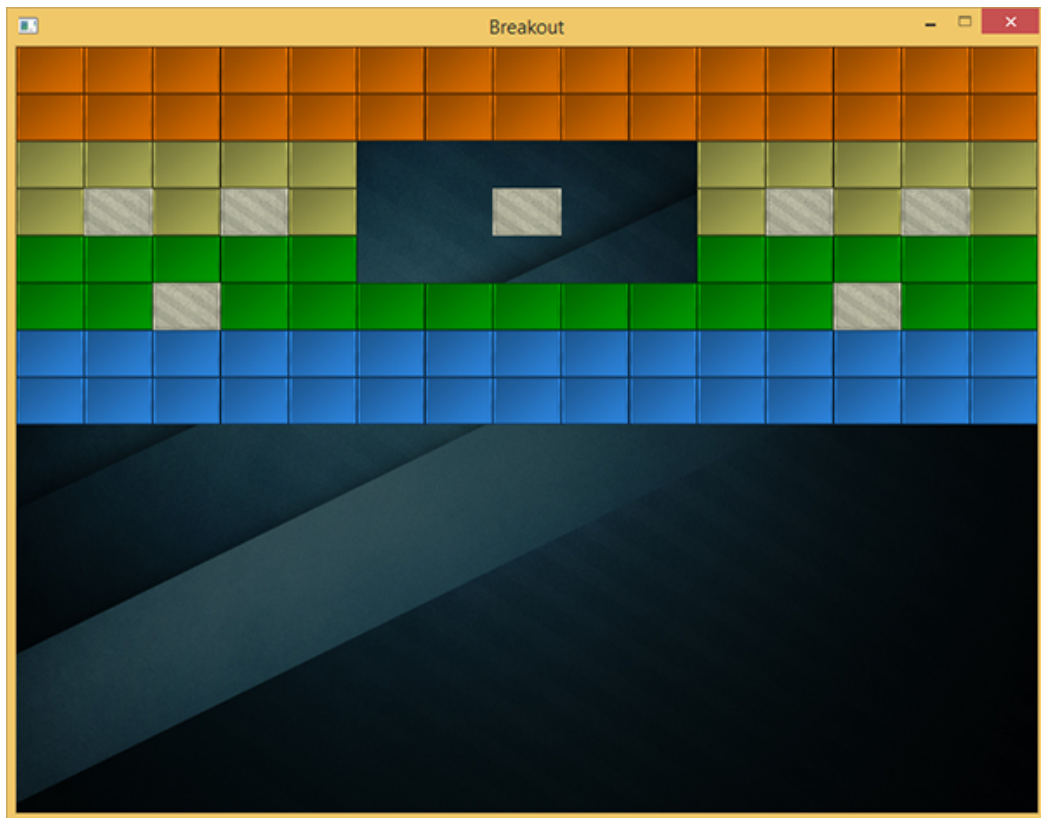

48.1.1 The player paddle

While we're at it, we might just as well introduce a paddle at the bottom of the scene that is controlled by the player. The paddle only allows for horizontal movement and whenever it touches any of the scene's edges, its movement should halt. For the player paddle we're going to use the [following](#) texture:

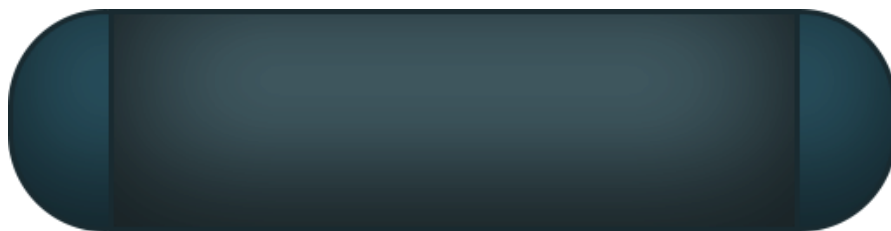

A paddle object will have a position, a size and a sprite texture, so it makes sense to define the paddle as a `GameObject` as well.

```
// Initial size of the player paddle
const glm::vec2 PLAYER_SIZE(100, 20);
// Initial velocity of the player paddle
const GLfloat PLAYER_VELOCITY(500.0f);

GameObject *Player;

void Game::Init()
{
    [...]
    ResourceManager::LoadTexture("textures/paddle.png", true, "paddle");
}
```

```
[...]
glm::vec2 playerPos = glm::vec2(
    this->Width / 2 - PLAYER_SIZE.x / 2,
    this->Height - PLAYER_SIZE.y
);
Player = new GameObject(playerPos, PLAYER_SIZE, ResourceManager::
    GetTexture("paddle"));
}
```

Here we defined several constant values that define the paddle's size and speed. Within the Game's `Init` functions we calculate the starting position of the paddle within the scene. We make sure the player paddle's center is aligned to the horizontal center of the scene.

With the player paddle initialized, we also need to add a statement to the Game's `Render` function:

```
Player->Draw(*Renderer);
```

If you'd start the game now you would not only see the level, but also a fancy player paddle aligned to the bottom edge of the scene. As of now, it doesn't really do anything besides just statically sitting there so we're also going to delve into the Game's `ProcessInput` function to horizontally move the paddle whenever the user pressed the `A` or `D` key.

```
void Game::ProcessInput(GLfloat dt)
{
    if (this->State == GAME_ACTIVE)
    {
        GLfloat velocity = PLAYER_VELOCITY * dt;
        // Move playerboard
        if (this->Keys[GLFW_KEY_A])
        {
            if (Player->Position.x >= 0)
                Player->Position.x -= velocity;
        }
        if (this->Keys[GLFW_KEY_D])
        {
            if (Player->Position.x <= this->Width - Player->Size.x)
                Player->Position.x += velocity;
        }
    }
}
```

Here we move the player paddle either in the left or right direction based on which key the user pressed (note how we multiply the velocity with the `deltatime` variable). If the paddle's `x` value would be less than 0 it would've moved outside the left edge so we only move the paddle to the left if the paddle's `x` value is higher than the left edge's `x` position (0.0). We do the same for when the paddle breaches the right edge, but we have to compare the right edge's position with the right edge of the paddle (subtract the paddle's width from the right edge's `x` position).

Now running the game gives us a player paddle that we can move all across the bottom edge.

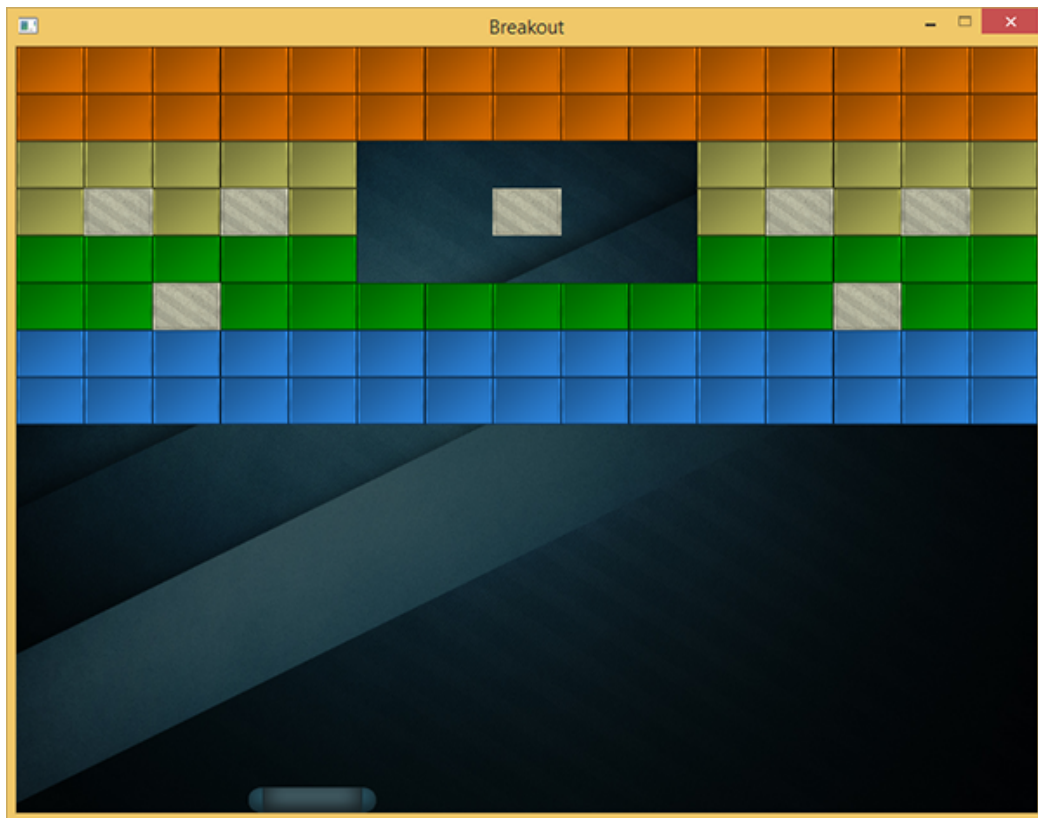

You can find the updated code of the Game class below:

- **Game:** [header](#), [code](#)



49. Ball

At this moment we have a level full of bricks and a movable player paddle. The only thing missing from the classic Breakout recipe is the ball. The objective is to let the ball collide with all the bricks until each of the destroyable bricks are destroyed, but this all within the condition that the ball is not allowed to reach the bottom edge of the screen.

Aside from the general game object components, a ball has a radius and an extra boolean value indicating whether the ball is **stuck** on the player paddle or its allowed free movement. When the game starts, the ball is initially stuck on the player paddle until the player starts the game by pressing some arbitrary key.

Because the ball is basically a `GameObject` with a few extra properties it makes sense to create a `BallObject` class as a subclass of `GameObject`:

```
class BallObject : public GameObject
{
public:
    // Ball state
    GLfloat Radius;
    GLboolean Stuck;

    BallObject();
    BallObject(glm::vec2 pos, GLfloat radius, glm::vec2 velocity,
Texture2D sprite);

    glm::vec2 Move(GLfloat dt, GLuint window_width);
    void      Reset(glm::vec2 position, glm::vec2 velocity);
};
```

The constructor of `BallObject` initializes its own values, but also initializes the underlying `GameObject`. The `BallObject` class hosts a `Move` function that moves the ball based on its

velocity and checks if it reaches any of the scene's edges and if so reverses the ball's velocity:

```
glm::vec2 BallObject::Move(GLfloat dt, GLuint window_width)
{
    // If not stuck to player board
    if (!this->Stuck)
    {
        // Move the ball
        this->Position += this->Velocity * dt;
        // Check if outside window bounds; if so, reverse velocity and
        // restore at correct position
        if (this->Position.x <= 0.0f)
        {
            this->Velocity.x = -this->Velocity.x;
            this->Position.x = 0.0f;
        }
        else if (this->Position.x + this->Size.x >= window_width)
        {
            this->Velocity.x = -this->Velocity.x;
            this->Position.x = window_width - this->Size.x;
        }
        if (this->Position.y <= 0.0f)
        {
            this->Velocity.y = -this->Velocity.y;
            this->Position.y = 0.0f;
        }
    }
    return this->Position;
}
```

Aside from reversing the ball's velocity we also want relocate the ball back along the edge. The ball is only able to move if it isn't stuck.

Because the player is game over (or loses a life) if the ball reaches the bottom edge there is no code to let the ball bounce of the bottom edge. We do need to later implement this logic somewhere in the game code though.

You can find the code for the ball object below:

- **BallObject:** [header](#), [code](#)

First let's add the ball to the game. Similar to the player paddle, we create a `BallObject` and define two constants that we use to initialize the ball. As the texture of the ball, we're going to use an image that makes perfect sense in a LearnOpenGL Breakout game: [ball texture](#).

```
// Initial velocity of the Ball
const glm::vec2 INITIAL_BALL_VELOCITY(100.0f, -350.0f);
// Radius of the ball object
const GLfloat BALL_RADIUS = 12.5f;

BallObject *Ball;

void Game::Init()
{
    [...]
```

```

glm::vec2 ballPos = playerPos + glm::vec2(PLAYER_SIZE.x / 2 -
BALL_RADIUS, -BALL_RADIUS * 2);
Ball = new BallObject(ballPos, BALL_RADIUS, INITIAL_BALL_VELOCITY,
    ResourceManager::GetTexture("face"));
}

```

Then we have to update the position of the ball each frame by calling its `Move` function within the game code's `Update` function:

```

void Game::Update(GLfloat dt)
{
    Ball->Move(dt, this->Width);
}

```

Furthermore, because the ball is initially stuck to the paddle, we have to give the player the ability to remove it from its stuck position. We select the space key for freeing the ball from the paddle. This means we have to change the `processInput` function a little:

```

void Game::ProcessInput(GLfloat dt)
{
    if (this->State == GAME_ACTIVE)
    {
        GLfloat velocity = PLAYER_VELOCITY * dt;
        // Move playerboard
        if (this->Keys[GLFW_KEY_A])
        {
            if (Player->Position.x >= 0)
            {
                Player->Position.x -= velocity;
                if (Ball->Stuck)
                    Ball->Position.x -= velocity;
            }
        }
        if (this->Keys[GLFW_KEY_D])
        {
            if (Player->Position.x <= this->Width - Player->Size.x)
            {
                Player->Position.x += velocity;
                if (Ball->Stuck)
                    Ball->Position.x += velocity;
            }
        }
        if (this->Keys[GLFW_KEY_SPACE])
            Ball->Stuck = false;
    }
}

```

Here, if the user presses the space bar, the ball's `Stuck` variable is set to `false`. We also updated the `ProcessInput` function to move the position of the ball alongside the paddle's position whenever the ball is stuck.

Last, we need to render the ball which by now should be fairly obvious:

```

void Game::Render()
{
    if (this->State == GAME_ACTIVE)

```

```
{
    [...]
    Ball->Draw(*Renderer);
}
```

The result is a ball that follows the paddle and roams freely whenever we press the spacebar. The ball also properly bounces of the left, right and top edge, but it doesn't yet seem to collide with any of the bricks as we can see in the following video:

[See video online](#)

What we want is to create one or several function(s) that check if the ball object is colliding with any of the bricks in the level and if so, destroy this brick. These so called **collision detection** functions is what we'll focus on in the [next](#) tutorial.

A futuristic cityscape with a flying vehicle in the foreground. The vehicle is dark with blue lights and is flying towards the left. The city is filled with tall, thin buildings and is shrouded in a light mist or fog. The sky is a pale blue with some clouds.

50. Collision detection

When trying to determine if a collision occurs between two objects, we generally do not use the data of the objects themselves since these objects are often quite complicated; this in turn also makes the collision detection complicated. For this reason, it is a common practice to use more simple shapes (that usually have a nice mathematical definition) for collision detection that we *overlay* on top of the original object. We then check for collisions based on these simple shapes which makes the code easier and saves a lot of performance. Several examples of such **collision shapes** are circles, spheres, rectangles and boxes; these are a lot simpler to work with compared to meshes with hundreds of triangles.

While they do give us easier and more efficient collision detection algorithms, the simpler collision shapes share a common disadvantage in that these shapes usually do not fully surround the object. The effect is that a collision might be detected that didn't really collide with the actual object; one should always keep in mind that these shapes are just approximations of the real shapes.

50.1 AABB - AABB collisions

AABB stands for **axis-aligned bounding box** which is a rectangular collision shape aligned to the base axes of the scene, which in 2D aligns to the x and y axis. Being axis-aligned means the rectangular box is not rotated and its edges are parallel to the base axes of the scene (e.g. left and right edge are parallel to the y axis). The fact that these boxes are always aligned to the axes of the scene makes all calculations easier. Here we surround the ball object with an AABB:

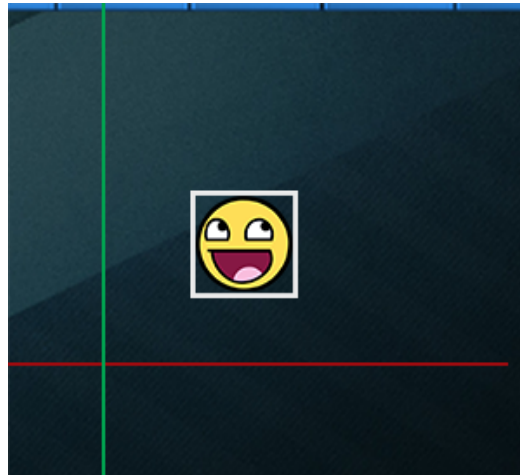

Almost all the objects in Breakout are rectangular based objects so it makes perfect sense to use axis aligned bounding boxes for detecting collisions. This is exactly what we're going to do.

Axis aligned bounding boxes can be defined in several ways. One of the ways to define an AABB is by having a top-left position and a bottom-right position. The `GameObject` class that we defined already contains a top-left position (its `Position` vector) and we can easily calculate its bottom-right position by adding its size to the top-left position vector (`Position + Size`). Effectively, each `GameObject` contains an AABB that we can use for collisions.

So how do we determine collisions? A collision occurs when two collision shapes enter each other's regions e.g. the shape that determines the first object is in some way inside the shape of the second object. For AABBs this is quite easy to determine due to the fact that they're aligned to the scene's axes: we check for each axis if the two object's edges on that axis overlap. So basically we check if the horizontal edges overlap and if the vertical edges overlap of both objects. If both the horizontal **and** vertical edges overlap we have a collision.

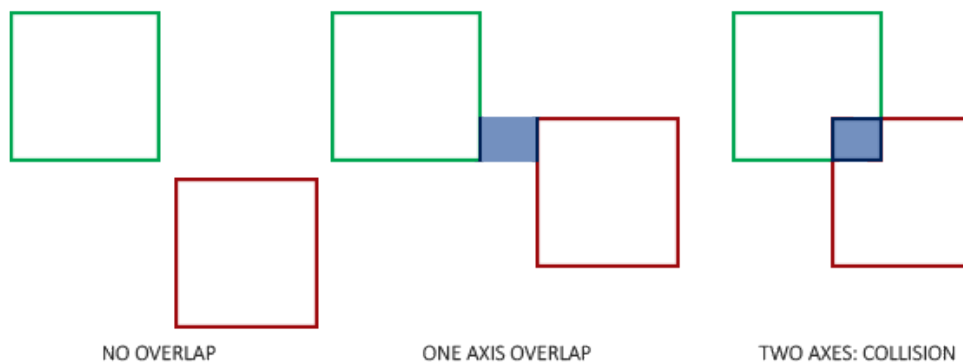

Translating this concept to code is quite straightforward. We check for overlap on both axes and if so, return a collision:

```
GLboolean CheckCollision(GameObject &one, GameObject &two) // AABB - AABB
collision
{
    // Collision x-axis?
    bool collisionX = one.Position.x + one.Size.x >= two.Position.x &&
        two.Position.x + two.Size.x >= one.Position.x;
```

```

// Collision y-axis?
bool collisionY = one.Position.y + one.Size.y >= two.Position.y &&
    two.Position.y + two.Size.y >= one.Position.y;
// Collision only if on both axes
return collisionX && collisionY;
}

```

We check if the right side of the first object is greater than the left side of the second object **and** if the second object's right side is greater than the first object's left side; similarly for the vertical axis. If you have trouble visualizing this, try to draw the edges/rectangles on paper and determine this for yourself.

To keep the collision code a bit more organized we add an extra function to the `Game` class:

```

class Game
{
public:
    [...]
    void DoCollisions();
};

```

Within `DoCollisions` we check for collisions between the ball object and each brick of the level. If we detect a collision, we set the brick's `Destroyed` property to `true` which also instantly stops the level from rendering this brick.

```

void Game::DoCollisions()
{
    for (GameObject &box : this->Levels[this->Level].Bricks)
    {
        if (!box.Destroyed)
        {
            if (CheckCollision(*Ball, box))
            {
                if (!box.IsSolid)
                    box.Destroyed = GL_TRUE;
            }
        }
    }
}

```

Then we also need to update the game's `Update` function:

```

void Game::Update(GLfloat dt)
{
    // Update objects
    Ball->Move(dt, this->Width);
    // Check for collisions
    this->DoCollisions();
}

```

If we run the code now, the ball should detect collisions with each of the bricks and if the brick is not solid, the brick is destroyed. If you run the game now it'll look something like this:

See video online

While the collision detection does work, it's not very precise since the ball collides with most of the bricks without directly touching them. Let's implement another collision detection technique.

50.2 AABB - Circle collision detection

Because the ball is a circle-like object an AABB is probably not the best choice as the ball's collision shape. The collision code thinks the ball is a rectangular box so the ball often collides with a brick even though the ball sprite itself isn't yet touching the brick.

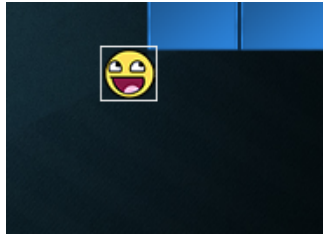

It makes much more sense to represent the ball with a circle collision shape instead of an AABB. For this reason we included a `Radius` variable within the ball object. To define a circle collision shape all we need is a position vector and a radius.



This does mean we have to update the detection algorithm since it currently only works between two AABBs. Detecting collisions between a circle and a rectangle is slightly more complicated, but the trick is as follows: we find the point on the AABB that is closest to the circle and if the distance from the circle to this point is less than its radius, we have a collision.

The difficult part is getting this closest point \bar{P} on the AABB. The following image shows how we can calculate this point for any arbitrary AABB and circle:

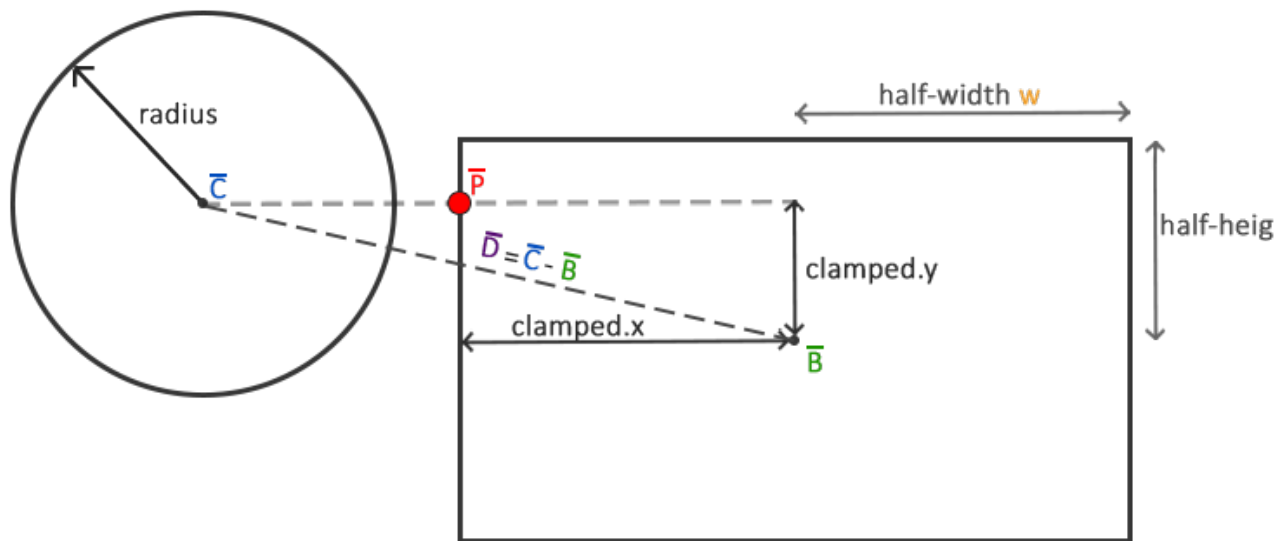

We first need to get the difference vector between the ball's center \bar{C} and the AABB's center \bar{B} to obtain \bar{D} . What we then need to do is **clamp** this vector \bar{D} to the AABB's half-extents w and h . The half-extents of a rectangle are the distances between the rectangle's center and its edges; basically its size divided by two. This returns a position vector that is always located somewhere at the edge of the AABB (unless the circle's center is inside the AABB).

A clamp operation **clamps** a value to a value within a given range. This is often expressed as:

```
float clamp(float value, float min, float max) {
    return std::max(min, std::min(max, value));
}
```

For example, a value of $42.0f$ is clamped as $6.0f$ between $3.0f$ and $6.0f$ and a value of $4.20f$ would be clamped to $4.20f$.

Clamping a 2D vector means we clamp both its x and its y component within the given range.

This clamped vector \bar{P} is then the closest point from the AABB to the circle. What we then need to do is calculate a new difference vector \bar{D}' that is the difference between the circle's center \bar{C} and the vector \bar{P} .

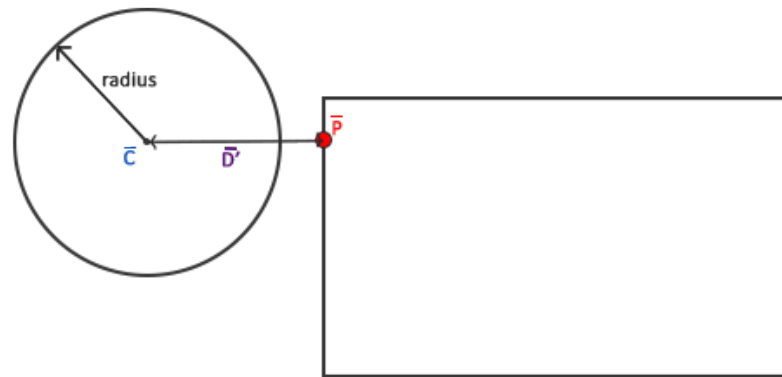

Now that we have the vector \vec{D} we can compare its length to the radius of the circle to determine if we have a collision.

This is all expressed in code as follows:

```
GLboolean CheckCollision(BallObject &one, GameObject &two) // AABB - Circle
collision
{
    // Get center point circle first
    glm::vec2 center(one.Position + one.Radius);
    // Calculate AABB info (center, half-extents)
    glm::vec2 aabb_half_extents(two.Size.x / 2, two.Size.y / 2);
    glm::vec2 aabb_center(
        two.Position.x + aabb_half_extents.x,
        two.Position.y + aabb_half_extents.y
    );
    // Get difference vector between both centers
    glm::vec2 difference = center - aabb_center;
    glm::vec2 clamped = glm::clamp(difference, -aabb_half_extents,
aabb_half_extents);
    // Add clamped value to AABB_center and we get the value of box closest
to circle
    glm::vec2 closest = aabb_center + clamped;
    // Retrieve vector between center circle and closest point AABB and
check if length <= radius
    difference = closest - center;
    return glm::length(difference) < one.Radius;
}
```

An overloaded function for `CheckCollision` was created that specifically deals with the case between a `BallObject` and a `GameObject`. Because we did not store the collision shape information in the objects themselves we have to calculate them: first the center of the ball is calculated, then the AABB's half-extents and its center.

Using these collision shape attributes we calculate vector \vec{D} as `difference` that we then clamp to `clamped` and add to the AABB's center to get point \vec{P} as `closest`. Then we calculate the difference vector \vec{D} between `center` and `closest` and return whether the two shapes collided or not.

Since we previously called `CheckCollision` with the ball object as its first argument, we do not have to change any code since the overloaded variant of `CheckCollision` now automatically applies. The result is now a much more precise collision detection algorithm.

See video online

It seems to work, but still something is off. We properly do all the collision detection, but the ball does not react in any way to the collisions. We need to **react** to the collisions e.g. update the ball's position and/or velocity whenever a collision occurs. This is the topic of the [next](#) tutorial.

A futuristic cityscape with a flying vehicle in the foreground. The vehicle is dark with blue glowing lights and is flying towards the left. The city is filled with tall, thin buildings and is shrouded in a light mist or fog. The sky is a pale blue.

51. Collision resolution

At the end of the last tutorial we had a working collision detection scheme. However, the ball does not react in any way to the detected collisions; it just moves straight through all the bricks. We want the ball to *bounce* of the collided bricks. This tutorial discusses how we can accomplish this so called **collision resolution** within the AABB - circle collision detection scheme.

Whenever a collision occurs we want two things to happen: we want to reposition the ball so it is no longer inside the other object and second, we want to change the direction of the ball's velocity so it looks like its bouncing of the object.

51.0.1 Collision repositioning

To position the ball object outside the collided AABB we have to figure out the distance the ball penetrated the bounding box. For this we'll revisit the diagrams from the previous tutorial:

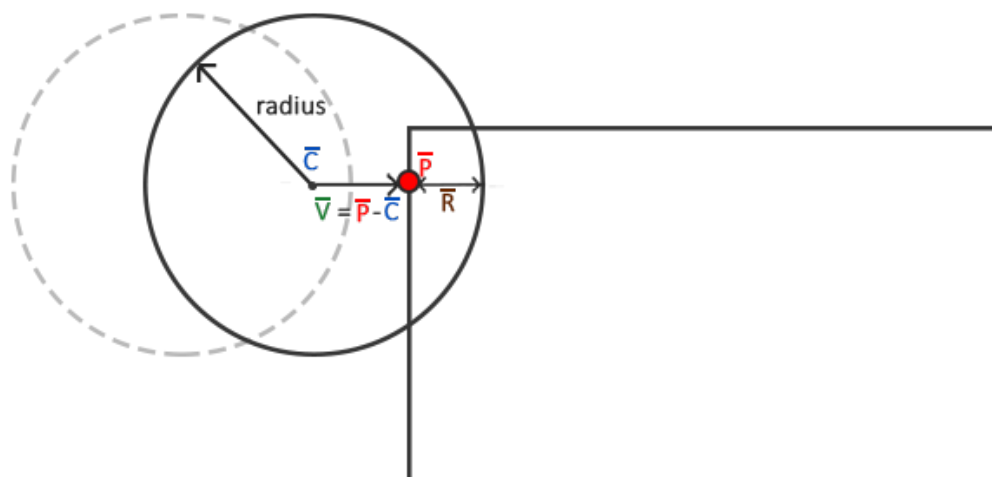

Here the ball moved slightly into the AABB and a collision was detected. We now want to move the ball out of the shape so that it merely touches the AABB as if no collision occurred. To figure out how much we need to move the ball out of the AABB we need to retrieve the vector \bar{R} which is the level of penetration into the AABB. To get this vector \bar{R} we subtract \bar{V} from the ball's radius. Vector \bar{V} is the difference between closest point \bar{P} and the ball's center \bar{C} .

Knowing \bar{R} we offset the ball's position by \bar{R} and position the ball directly alongside the AABB; the ball is now properly positioned.

51.0.2 Collision direction

Next we need to figure out how to update the ball's velocity after a collision. For Breakout we use the following rules to change the ball's velocity:

1. If the ball collides with the right or left side of an AABB, its horizontal velocity (x) is reversed.
2. If the ball collides with the bottom or top side of an AABB, its vertical velocity (y) is reversed.

But how do we figure out the direction the ball hit the AABB? There are several approaches to this problem and one of them is that instead of 1 AABB we use 4 AABBs for each brick that we position each at one of its edges. This way we can determine which AABB and thus which edge was hit. However, a simpler approach exists with the help of the dot product.

You probably still remember from the [transformations](#) tutorial that the dot product gives us the angle between two normalized vectors. What if we were to define four vectors pointing north, south, west or east and calculate the dot product between them and a given vector? The resulting dot product between these four direction vectors and the given vector that is highest (dot product's maximum value is 1.0 if which represents a 0 degree angle) is then the direction of the vector.

This procedure looks as follows in code:

```
Direction VectorDirection(glm::vec2 target)
{
    glm::vec2 compass[] = {
```

```

    glm::vec2(0.0f, 1.0f), // up
    glm::vec2(1.0f, 0.0f), // right
    glm::vec2(0.0f, -1.0f), // down
    glm::vec2(-1.0f, 0.0f) // left
};
GLfloat max = 0.0f;
GLuint best_match = -1;
for (GLuint i = 0; i < 4; i++)
{
    GLfloat dot_product = glm::dot(glm::normalize(target), compass[i]);
    if (dot_product > max)
    {
        max = dot_product;
        best_match = i;
    }
}
return (Direction)best_match;
}

```

The function compares `target` to each of the direction vectors in the `compass` array. The compass vector `target` is closest to in angle, is the direction returned to the function caller. Here `Direction` is part of an enum defined in the game class's header file:

```

enum Direction {
    UP,
    RIGHT,
    DOWN,
    LEFT
};

```

Now that we know how to get vector \vec{R} and how to determine the direction the ball hit the AABB we can start writing the collision resolution code.

51.0.3 AABB - Circle collision resolution

To calculate the required values for collision resolution we need a bit more information from the collision function(s) than just a `true` or `false` so we're going to return a `tuple` of information, namely if a collision occurred, what direction it occurred and the difference vector (\vec{R}). You can find the `tuple` container in the `<tuple>` header.

To keep the code slightly more organized we'll typedef the collision relevant data as `Collision`:

```

typedef std::tuple<GLboolean, Direction, glm::vec2> Collision;

```

Then we also have to change the code of the `CheckCollision` function to not only return `true` or `false`, but also the direction and difference vector:

```

Collision CheckCollision(BallObject &one, GameObject &two) // AABB - AABB
collision
{
    [...]
    if (glm::length(difference) <= one.Radius)
        return std::make_tuple(GL_TRUE, VectorDirection(difference),
            difference);
}

```

```

else
    return std::make_tuple(GL_FALSE, UP, glm::vec2(0, 0));
}

```

The game's `DoCollision` function now doesn't just check if a collision occurred, but also acts appropriately whenever a collision did occur. The function now calculates the level of penetration (as shown in the diagram at the start of this tutorial) and adds or subtracts it from the ball's position based on the direction of the collision.

```

void Game::DoCollisions()
{
    for (GameObject &box : this->Levels[this->Level].Bricks)
    {
        if (!box.Destroyed)
        {
            Collision collision = CheckCollision(*Ball, box);
            if (std::get<0>(collision)) // If collision is true
            {
                // Destroy block if not solid
                if (!box.IsSolid)
                    box.Destroyed = GL_TRUE;
                // Collision resolution
                Direction dir = std::get<1>(collision);
                glm::vec2 diff_vector = std::get<2>(collision);
                if (dir == LEFT || dir == RIGHT) // Horizontal collision
                {
                    Ball->Velocity.x = -Ball->Velocity.x; // Reverse
horizontal velocity
                    // Relocate
                    GLfloat penetration = Ball->Radius - std::abs(
diff_vector.x);
                    if (dir == LEFT)
right
                        Ball->Position.x += penetration; // Move ball to
                    else
left;
                        Ball->Position.x -= penetration; // Move ball to
                }
                else // Vertical collision
                {
                    Ball->Velocity.y = -Ball->Velocity.y; // Reverse
vertical velocity
                    // Relocate
                    GLfloat penetration = Ball->Radius - std::abs(
diff_vector.y);
                    if (dir == UP)
up
                        Ball->Position.y -= penetration; // Move ball back
                    else
down
                        Ball->Position.y += penetration; // Move ball back
                }
            }
        }
    }
}

```

Don't get too scared by the function's complexity since it is basically a direct translation of the concepts introduced so far. First we check for a collision and if so we destroy the block if it is

non-solid. Then we obtain the collision direction `dir` and the vector \vec{V} as `diff_vector` from the tuple and finally do the collision resolution.

We first check if the collision direction is either horizontal or vertical and then reverse the velocity accordingly. If horizontal, we calculate the penetration value R from the `diff_vector`'s x component and either add or subtract this from the ball's position based on its direction. The same applies to the vertical collisions, but this time we operate on the y component of all the vectors.

Running your application should now give you a working collision scheme, but it's probably difficult to really see its effect since the ball will bounce towards the bottom edge as soon as you hit a single block and be lost forever. We can fix this by also handling player paddle collisions.

51.1 Player - ball collisions

Collisions between the ball and the player are slightly different than what we've previously discussed since this time the ball's horizontal velocity should be updated based on how far it hit the paddle from its center. The further the ball hits the paddle from its center, the stronger its horizontal velocity should be.

```
void Game::DoCollisions()
{
    [...]
    Collision result = CheckCollision(*Ball, *Player);
    if (!Ball->Stuck && std::get<0>(result))
    {
        // Check where it hit the board, and change velocity based on where
        it hit the board
        GLfloat centerBoard = Player->Position.x + Player->Size.x / 2;
        GLfloat distance = (Ball->Position.x + Ball->Radius) - centerBoard;
        GLfloat percentage = distance / (Player->Size.x / 2);
        // Then move accordingly
        GLfloat strength = 2.0f;
        glm::vec2 oldVelocity = Ball->Velocity;
        Ball->Velocity.x = INITIAL_BALL_VELOCITY.x * percentage * strength;
        Ball->Velocity.y = -Ball->Velocity.y;
        Ball->Velocity = glm::normalize(Ball->Velocity) * glm::length(
oldVelocity);
    }
}
```

After we checked collisions between the ball and each brick, we'll check if the ball collided with the player paddle. If so (and the ball is not stuck to the paddle) we calculate the percentage of how far the ball's center is removed from the paddle's center compared to the half-extent of the paddle. The horizontal velocity of the ball is then updated based on the distance it hit the paddle from its center. Aside from updating the horizontal velocity we also have to reverse the y velocity.

Note that the old velocity is stored as `oldVelocity`. The reason for storing the old velocity is that we only update the horizontal velocity of the ball's velocity vector while keeping its y velocity constant. This would mean that the length of the vector constantly changes which has the effect that the ball's velocity vector is much larger (and thus stronger) if the ball hit the edge of the paddle compared to if the ball would hit the center of the paddle. For this reason the new velocity

vector is normalized and multiplied by the length of the old velocity vector. This way, the strength and thus the velocity of the ball is always consistent, regardless of where it hits the paddle.

51.1.1 Sticky paddle

You may or may not have noticed it when you ran the code, but there is still a large issue with the player and ball collision resolution. The following video clearly shows what might happen:

See video online

This issue is called the **sticky paddle** issue which happens because the player paddle moves with a high velocity towards the ball that results in the ball's center ending up inside the player paddle. Since we did not account for the case where the ball's center is inside an AABB the game tries to continuously react to all the collisions and once it finally breaks free it will have reversed its y velocity so much that it's unsure whether it goes up or down after breaking free.

We can easily fix this behavior by introducing a small hack which is possible due to the fact that we can assume we always have a collision at the top of the paddle. Instead of reversing the y velocity we simply always return a positive y direction so whenever it does get stuck, it will immediately break free.

```
//Ball->Velocity.y = -Ball->Velocity.y;  
Ball->Velocity.y = -1 * abs(Ball->Velocity.y);
```

If you try hard enough the effect is still noticeable, but I personally find it an acceptable trade-off.

51.1.2 The bottom edge

The only thing that is still missing from the classic Breakout recipe is some loss condition that resets the level and the player. Within the game class's `Update` function we want to check if the ball reached the bottom edge, and if so, reset the game.

```
void Game::Update(GLfloat dt)  
{  
    [...]  
    if (Ball->Position.y >= this->Height) // Did ball reach bottom edge?  
    {  
        this->ResetLevel();  
        this->ResetPlayer();  
    }  
}
```

The `ResetLevel` and `ResetPlayer` functions simply re-load the level and reset the objects' values to their original starting values. The game should now look a bit like this:

See video online

And there you have it, we just finished creating a clone of the classical Breakout game with similar mechanics. You can find the game class' source code here: [header](#), [code](#).

51.2 A few notes

Collision detection is a difficult topic of video game development and possibly its most challenging. Most collision detection and resolution schemes are combined with physics engines as found in most modern-day games. The collision scheme we used for the Breakout game is a very simple scheme and one specialized specifically for this type of game.

It should be stressed that this type of collision detection and resolution is not perfect. It calculates possible collisions only per frame and only for the positions exactly as they are at that timestep; this means that if an object would have such a velocity that it would pass over another object within a single frame, it would look like it never collided with this object. So if there are framedrops or you reach high enough velocities, this collision detection scheme will not hold.

Several of the issues that can still occur:

- If the ball goes too fast, it might skip over an object entirely within a single frame, not detecting any collisions.
- If the ball hits more than one object within a single frame, it will have detected two collisions and reverse its velocity twice; not affecting its original velocity.
- Hitting a corner of a brick could reverse the ball's velocity in the wrong direction since the distance it travels in a single frame could make the difference between `VectorDirection` returning a vertical or horizontal direction.

These tutorials are however aimed to teach the readers the basics of several aspects of graphics and game-development. For this reason, this collision scheme serves its purpose; its understandable and works quite well in normal scenarios. Just keep in mind that there exist better (more complicated) collision schemes that work quite well in almost all scenarios (including movable objects) like the [separating axis theorem](#).

Thankfully, there exist large, practical and often quite efficient physics engines (with timestep-independent collision schemes) for use in your own games. If you wish to delve further into such systems or need more advanced physics and have trouble figuring out the mathematics, [Box2D](#) is a perfect 2D physics library for implementing physics and collision detection in your applications.

A futuristic cityscape with a flying vehicle emitting blue light trails. The vehicle is a sleek, dark-colored craft with several bright blue lights on its front and sides. It is flying through a dense forest of tall, thin, futuristic buildings that resemble a city. The sky is a mix of blue and grey, suggesting a hazy or overcast day. The overall scene is dynamic and high-tech.

52. Particles

A **particle**, as seen from OpenGL's perspective, is a tiny 2D quad that is always faced at the camera (billboarding) and (usually) contains a texture with large parts of the sprite being transparent. A particle by itself is basically just a sprite as we've been extensively using so far, but when you put together hundreds or even thousands of these particles together you can create amazing effects.

When working with particles, there is usually an object called a **particle emitter** or **particle generator** that, from its location, continuously **spawns** new particles that decay over time. If such a particle emitter would for example spawn tiny particles with a smoke-like texture, color them less bright the larger the distance from the emitter and give them a glowy appearance you'd get a fire-like effect:

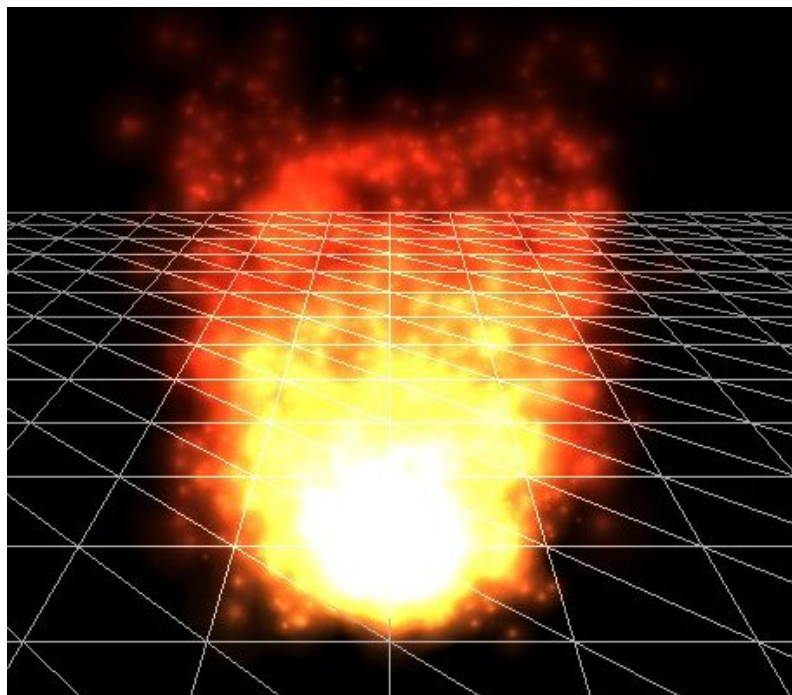

A single particle often has a life variable that slowly decays once it is spawned. Once its life is less than a certain threshold (usually 0) we **kill** the particle so it can be replaced with a new particle object when the next particle spawns. A particle emitter controls all its spawned particles and changes their behavior based on their attributes. A particle generally has the following attributes:

```
struct Particle {
    glm::vec2 Position, Velocity;
    glm::vec4 Color;
    GLfloat Life;

    Particle()
        : Position(0.0f), Velocity(0.0f), Color(1.0f), Life(0.0f) { }
};
```

Looking at the fire example, the particle emitter probably spawns each particle with a position close to the emitter and with an upwards velocity so each particle moves in the positive y direction. It seems to have 3 different regions so it probably gives some particles a higher velocity than others. We can also see that the higher the y position of the particle, the less *yellow* or *bright* its color becomes. After the particles have reached a certain height, their life is depleted and the particles are killed; never reaching the stars.

You can imagine that with systems like these we can create interesting effects like fire, smoke, fog, magic effects, gunfire residue etc. In Breakout we're going to add a simple particle generator following the ball to make it all look more interesting. It'll look a bit like this:

See video online

Here the particle generator spawns each particle at the ball's position, gives it a velocity equal to a fraction of the ball's velocity and changes the color of the particle based on how long it lived.

For rendering the particles we'll be using a different set of shaders:

```

#version 330 core
layout (location = 0) in vec4 vertex; // <vec2 position, vec2 texCoords>

out vec2 TexCoords;
out vec4 ParticleColor;

uniform mat4 projection;
uniform vec2 offset;
uniform vec4 color;

void main()
{
    float scale = 10.0f;
    TexCoords = vertex.zw;
    ParticleColor = color;
    gl_Position = projection * vec4((vertex.xy * scale) + offset, 0.0, 1.0)
    ;
}

```

And the fragment shader:

```

#version 330 core
in vec2 TexCoords;
in vec4 ParticleColor;
out vec4 color;

uniform sampler2D sprite;

void main()
{
    color = (texture(sprite, TexCoords) * ParticleColor);
}

```

We take the standard position and texture attributes per particle and also accept an `offset` and a `color` uniform for changing the outcome per particle. Note that in the vertex shader we scale the particle quad by `10.0f`; you could also set the scale as a uniform and control this individually per particle.

First, we need a list of particles that we then instantiate with default `Particle` structs.

```

GLuint nr_particles = 500;
std::vector<Particle> particles;

for (GLuint i = 0; i < nr_particles; ++i)
    particles.push_back(Particle());

```

Then in each frame, we spawn several new particles with starting values and then for each particle that is (still) alive we update their values.

```

GLuint nr_new_particles = 2;
// Add new particles
for (GLuint i = 0; i < nr_new_particles; ++i)
{
    int unusedParticle = FirstUnusedParticle();
    RespawnParticle(particles[unusedParticle], object, offset);
}

```

```
// Update all particles
for (GLuint i = 0; i < nr_particles; ++i)
{
    Particle &p = particles[i];
    p.Life -= dt; // reduce life
    if (p.Life > 0.0f)
    {
        // particle is alive, thus update
        p.Position -= p.Velocity * dt;
        p.Color.a -= dt * 2.5;
    }
}
```

The first loop might look a little daunting. Because particles die over time we want to spawn `nr_new_particles` particles each frame, but since we've decided from the start that the total amount of particles we'll be using is `nr_particles` we can't simply push the new particles to the end of the list. This way we'll quickly get a list filled with thousands of particles which isn't really efficient considering only a small portion of that list has particles that are alive.

What we want is to find the first particle that is dead (`life < 0.0f`) and update that particle as a new respawned particle.

The function `FirstUnusedParticle` tries to find the first particle that is dead and returns its index to the caller.

```
GLuint lastUsedParticle = 0;
GLuint FirstUnusedParticle()
{
    // Search from last used particle, this will usually return almost
    // instantly
    for (GLuint i = lastUsedParticle; i < nr_particles; ++i){
        if (particles[i].Life <= 0.0f){
            lastUsedParticle = i;
            return i;
        }
    }
    // Otherwise, do a linear search
    for (GLuint i = 0; i < lastUsedParticle; ++i){
        if (particles[i].Life <= 0.0f){
            lastUsedParticle = i;
            return i;
        }
    }
    // Override first particle if all others are alive
    lastUsedParticle = 0;
    return 0;
}
```

The function stores the index of the last dead particle it found, since the next dead particle will most likely be right after this last particle index so we first search from this stored index. If we did not find any dead particles, we simply do a slower linear search. If no particles are dead it will return the index 0 which results in the first particle being overwritten. Note that if it reaches this last case, it means your particles are alive for too long, you need to spawn less particles per frame and/or you simply don't have enough particles reserved.

Then, once the first dead particle in the list is found, we update its values by calling `RespawnParticle` that takes the particle, a `GameObject` and an offset vector:

```

void RespawnParticle(Particle &particle, GameObject &object, glm::vec2
    offset)
{
    GLfloat random = ((rand() % 100) - 50) / 10.0f;
    GLfloat rColor = 0.5 + ((rand() % 100) / 100.0f);
    particle.Position = object.Position + random + offset;
    particle.Color = glm::vec4(rColor, rColor, rColor, 1.0f);
    particle.Life = 1.0f;
    particle.Velocity = object.Velocity * 0.1f;
}

```

This function simply resets the particle's life to 1.0f, randomly gives it a brightness (via the color vector) starting from 0.5 and assigns a (slightly random) position and velocity based on the game object.

The second loop within the update function loops through all the particles and for each particle reduces its life by the delta time variable; this way each particle's life corresponds to exactly the second(s) it's allowed to live. Then we check if the particle is alive and if so, update its position and color attributes. Here we slowly reduce the alpha component of each particle so it looks like they're slowly disappearing over time.

Then what's left is to actually render the particles:

```

glBlendFunc(GL_SRC_ALPHA, GL_ONE);
particleShader.Use();
for (Particle particle : particles)
{
    if (particle.Life > 0.0f)
    {
        particleShader.SetVector2f("offset", particle.Position);
        particleShader.SetVector4f("color", particle.Color);
        particleTexture.Bind();
        glBindVertexArray(particleVAO);
        glDrawArrays(GL_TRIANGLES, 0, 6);
        glBindVertexArray(0);
    }
}
glBlendFunc(GL_SRC_ALPHA, GL_ONE_MINUS_SRC_ALPHA);

```

Here, for each particle, we set their offset and color uniform values, bind the texture and render the 2D quad. What is interesting to see here are the two calls to `glBlendFunc`. When rendering the particles, instead of the default destination blending mode of `GL_ONE_MINUS_SRC_ALPHA` we use the `GL_ONE` blending mode that gives the particles a very neat **glow effect** when stacked upon each other. This is also likely the blending mode used when rendering the fire at the top of the tutorial, since the fire got glowy at the center where most of its particles were.

Because we (like most other parts of the tutorial series) like to keep things organized, another class called `ParticleGenerator` was created that hosts all the functionality we just talked about. You can find the source code below:

- [header, code](#)

Then within the game code, we create such a particle generator and initialize it with [this](#) texture.

```

ParticleGenerator *Particles;

void Game::Init ()
{
    [...]
    ResourceManager::LoadShader("shaders/particle.vs", "shaders/particle.
    frag", nullptr, "particle");
    [...]
    ResourceManager::LoadTexture("textures/particle.png", GL_TRUE, "
    particle");
    [...]
    Particles = new ParticleGenerator(
        ResourceManager::GetShader("particle"),
        ResourceManager::GetTexture("particle"),
        500
    );
}

```

Then we change the game class's `Update` function by adding an update statement for the particle generator:

```

void Game::Update(GLfloat dt)
{
    [...]
    // Update particles
    Particles->Update(dt, *Ball, 2, glm::vec2(Ball->Radius / 2));
    [...]
}

```

Each of the particles will use the game object properties from the ball object, spawn 2 particles each frame and their positions will be offset towards the center of the ball. Last up is rendering the particles:

```

void Game::Render ()
{
    if (this->State == GAME_ACTIVE)
    {
        [...]
        // Draw player
        Player->Draw(*Renderer);
        // Draw particles
        Particles->Draw();
        // Draw ball
        Ball->Draw(*Renderer);
    }
}

```

Note that we render the particles before the ball is rendered and after the other item are rendered so the particles will end up in front of all other objects, but stay behind the ball. You can find the updated game class code [here](#).

If you'd now compile and run your application you should see a trail of particles following the ball, just like at the beginning of this tutorial, giving the game a more modern look. The system can also easily be extended to host more advanced effects so feel free to experiment with the particle generation and see if you can come up with your own creative effects.



53. Postprocessing

Wouldn't it be fun if we could completely spice up the visuals of the Breakout game with just a few postprocessing effects? We could create a blurry shake effect, inverse all the colors of the scene, do crazy vertex movement and/or make use of other interesting effects with relative ease thanks to OpenGL's framebuffer.

This tutorial makes extensive use of concepts from the [framebuffers](#) and [anti-aliasing](#) tutorials.

In the framebuffers tutorial we demonstrated how one could use postprocessing effects to achieve interesting effects using just a single texture. In Breakout we're going to do something similar: we're going to create a framebuffer object with a multisampled renderbuffer object attached as its color attachment. All the game's render code should render to this multisampled framebuffer that then blits its content to a different framebuffer with a texture attachment as its color buffer. This texture contains the rendered anti-aliased image of the game that we'll render to a large 2D quad with zero or more postprocessing effects applied.

So to summarize these rendering steps:

1. Bind to multisampled framebuffer
2. Render game as normal
3. Blit multisampled framebuffer to normal framebuffer
4. Unbind framebuffers (use default framebuffer)
5. Use color buffer texture from normal framebuffer in postprocessing shader
6. Render quad of screen-size as output of postprocessing shader

The postprocessing shader allows for three type of effects: shake, confuse and chaos.

- **shake**: slightly shakes the scene with a small blur.
- **confuse**: inverses the colors of the scene, but also the x and y axis.

- **chaos**: makes use of an edge detection kernel to create interesting visuals and also moves the textured image in a circular fashion for an interesting *chaotic* effect.

Below is a glimpse of what these effects are going to look like:

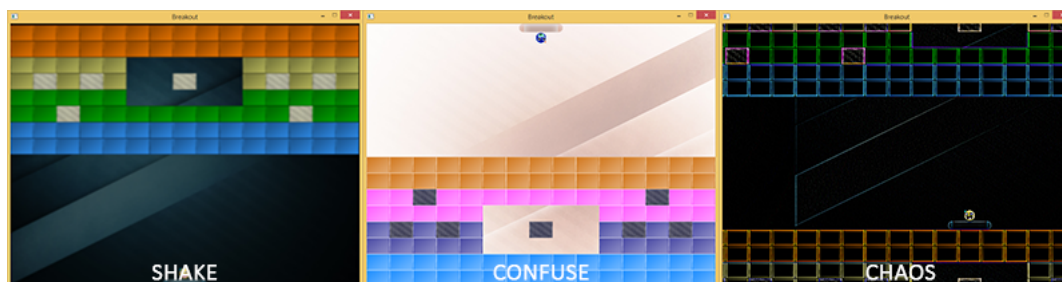

Operating on a 2D quad, the vertex shader looks as follows:

```
#version 330 core
layout (location = 0) in vec4 vertex; // <vec2 position, vec2 texCoords>

out vec2 TexCoords;

uniform bool chaos;
uniform bool confuse;
uniform bool shake;
uniform float time;

void main()
{
    gl_Position = vec4(vertex.xy, 0.0f, 1.0f);
    vec2 texture = vertex.zw;
    if(chaos)
    {
        float strength = 0.3;
        vec2 pos = vec2(texture.x + sin(time) * strength, texture.y + cos(
time) * strength);
        TexCoords = pos;
    }
    else if(confuse)
    {
        TexCoords = vec2(1.0 - texture.x, 1.0 - texture.y);
    }
    else
    {
        TexCoords = texture;
    }
    if (shake)
    {
        float strength = 0.01;
        gl_Position.x += cos(time * 10) * strength;
        gl_Position.y += cos(time * 15) * strength;
    }
}
```

Based on whatever uniform is set to `true` the vertex shader can take different paths. If either `chaos` or `confuse` is set to `true` the vertex shader will manipulate the texture coordinates to move the scene around (either translate texture coordinates in a circle-like fashion or inverse the texture coordinates). Because we set the texture wrapping methods to `GL_REPEAT` the chaos effect will cause the scene to repeat itself at various parts of the quad. Additionally if `shake` is set

to `true` it will move the vertex positions around by only a small amount. Note that `chaos` and `confuse` shouldn't be `true` at the same time while `shake` is able to work with any of the other effects on.

Aside from offsetting the vertex positions or texture coordinates, we'd also like to create a significant visual impact as soon as any of the effects are active. We can accomplish this within the fragment shader:

```
#version 330 core
in vec2 TexCoords;
out vec4 color;

uniform sampler2D scene;
uniform vec2 offsets[9];
uniform int edge_kernel[9];
uniform float blur_kernel[9];

uniform bool chaos;
uniform bool confuse;
uniform bool shake;

void main()
{
    vec3 sample[9];
    // sample from texture offsets if using convolution matrix
    if(chaos || shake)
        for(int i = 0; i < 9; i++)
            sample[i] = vec3(texture(scene, TexCoords.st + offsets[i]));

    // process effects
    if(chaos)
    {
        for(int i = 0; i < 9; i++)
            color += vec4(sample[i] * edge_kernel[i], 0.0f);
        color.a = 1.0f;
    }
    else if(confuse)
    {
        color = vec4(1.0 - texture(scene, TexCoords).rgb, 1.0);
    }
    else if(shake)
    {
        for(int i = 0; i < 9; i++)
            color += vec4(sample[i] * blur_kernel[i], 0.0f);
        color.a = 1.0f;
    }
    else
    {
        color = texture(scene, TexCoords);
    }
}
```

This long shader almost directly builds upon the fragment shader from the framebuffer tutorial and processes a postprocessing effects based on the effect type activated. This time though, the offset matrix and convolution kernels are defined as a uniform that we set from the application code. The advantage is that we only have to set this once, instead of recalculating these matrices in each fragment shader run. For example, the `offsets` matrix is configured as follows:

```

GLfloat offset = 1.0f / 300.0f;
GLfloat offsets[9][2] = {
    { -offset, offset }, // top-left
    { 0.0f,    offset }, // top-center
    { offset,  offset }, // top-right
    { -offset, 0.0f    }, // center-left
    { 0.0f,    0.0f    }, // center-center
    { offset,  0.0f    }, // center - right
    { -offset, -offset }, // bottom-left
    { 0.0f,   -offset }, // bottom-center
    { offset,  -offset } // bottom-right
};
glUniform2fv(glGetUniformLocation(shader.ID, "offsets"), 9, (GLfloat*)
    offsets);

```

Since all of the concepts of managing (multisampled) framebuffers were already extensively discussed in earlier tutorials I won't delve into the details this time. Below you'll find the code of a `PostProcessor` class that manages initialization, writing/reading the framebuffers and rendering a screen quad. You should be able to completely understand the code if you understood the framebuffers and anti-aliasing tutorials.

- **PostProcessor:** [header](#), [code](#).

What is interesting to note are the `BeginRender` and `EndRender` functions. Since we have to render the entire game scene into the framebuffer we can conveniently call `BeginRender()` and `EndRender()` before and after the scene's rendering code respectively. The class will then handle the behind-the-scenes framebuffer operations. For example, using the `PostProcessor` class then looks like this within the game's `Render` function:

```

PostProcessor *Effects;

void Game::Render()
{
    if (this->State == GAME_ACTIVE)
    {
        Effects->BeginRender();
        // Draw background
        // Draw level
        // Draw player
        // Draw particles
        // Draw ball
        Effects->EndRender();
        Effects->Render(glFWGetTime());
    }
}

```

Wherever we want we can now conveniently set the required effect property of the postprocessing class to `true` and its effect will be immediately visible.

53.0.1 Shake it

As a (practical) demonstration of these effects we'll emulate the visual impact of a ball when it hits a solid concrete block. By enabling the shake effect for a short period of time wherever a solid collision occurs, it'll look like the collision had a stronger impact.

We want to enable the shake effect only over a small period of time. We can get this to work by creating a variable called `ShakeTime` that holds the duration the shake effect is supposed to be active. Wherever a solid collision occurs, we reset this variable to a specific duration:

```
GLfloat ShakeTime = 0.0f;

void Game::DoCollisions()
{
    for (GameObject &box : this->Levels[this->Level].Bricks)
    {
        if (!box.Destroyed)
        {
            Collision collision = CheckCollision(*Ball, box);
            if (std::get<0>(collision) // If collision is true
            {
                // Destroy block if not solid
                if (!box.IsSolid)
                    box.Destroyed = GL_TRUE;
                else
                { // if block is solid, enable shake effect
                    ShakeTime = 0.05f;
                    Effects->Shake = true;
                }
                [...]
            }
        }
    }
    [...]
}
```

Then within the game's `Update` function we decrease this `ShakeTime` variable until it's `0.0` after which we disable the shake effect:

```
void Game::Update(GLfloat dt)
{
    [...]
    if (ShakeTime > 0.0f)
    {
        ShakeTime -= dt;
        if (ShakeTime <= 0.0f)
            Effects->Shake = false;
    }
}
```

Then each time we hit a solid block the screen briefly starts to shake and blur, giving the player some visual feedback the ball collided with a solid object.

See video online

You can find the updated source code of the game class [here](#).

In the [next](#) tutorial about powerups we'll bring the other two postprocessing effects to good use.



54. Powerups

Breakout is close to finished, but it would be cool to at least add one more gameplay mechanic so it's not your average standard Breakout clone; what about powerups?

The idea is that whenever a brick is destroyed, the brick has a small chance of spawning a powerup block. Such a block will slowly fall downwards and if it collides with the player paddle, an interesting effect occurs based on the type of powerup. For example, one powerup makes the paddle larger and another powerup allows the ball to pass through objects. We also include several negative powerups that affect the player in a negative way.

We can model a powerup as basically a `GameObject` with a few extra properties. That's why we define a class `PowerUp` that inherits from `GameObject` and adds these extra properties to the object:

```
const glm::vec2 SIZE(60, 20);
const glm::vec2 VELOCITY(0.0f, 150.0f);

class PowerUp : public GameObject
{
public:
    // PowerUp State
    std::string Type;
    GLfloat Duration;
    GLboolean Activated;
    // Constructor
    PowerUp(std::string type, glm::vec3 color, GLfloat duration,
            glm::vec2 position, Texture2D texture)
        : GameObject(position, SIZE, texture, color, VELOCITY),
          Type(type), Duration(duration), Activated()
    { }
};
```

A `PowerUp` is just a `GameObject` with extra state, so we can simply define it in a single header file which you can find [here](#).

Each powerup defines its type as a string, has a duration of how long it is active and whether it is currently activated. Within `Breakout` we're going to feature a total of 4 positive powerups and 2 negative powerups:



- **Speed:** increases the velocity of the ball by 20%.
- **Sticky:** when the ball collides with the paddle, the ball remains stuck to the paddle unless the spacebar is pressed again. This allows the player to better position the ball before releasing it.
- **Pass-Through:** collision resolution is disabled for non-solid blocks allowing the ball to pass through multiple blocks.
- **Pad-Size-Increase:** increases the width of the paddle by 50 pixels.
- **Confuse:** activates the confuse postprocessing effect for a short period of time, confusing the user.
- **Chaos:** activates the chaos postprocessing effect for a short period of time, heavily disorienting the user.

You can find the high-quality textures below:

- **Textures:** [Speed](#), [Sticky](#), [Pass-Through](#), [Pad-Size-Increase](#), [Confuse](#), [Chaos](#).

Similar to the level block textures, each of the powerup textures is completely grayscale. This makes sure the color of the powerups remain balanced whenever we multiply it with a color vector.

Because powerups have state, a duration and certain effects associated with them we would like to keep track of all the powerups currently active in the game; we store them in a vector:

```
class Game {
public:
    [...]
    std::vector<PowerUp> PowerUps;
    [...]
    void SpawnPowerUps(GameObject &block);
    void UpdatePowerUps(GLfloat dt);
};
```

We've also defined two functions for managing powerups. `SpawnPowerUps` spawns a powerup at the location of a given block and `UpdatePowerUps` manages all powerups currently active within the game.

54.0.1 Spawning PowerUps

Each time a block is destroyed we would like to, given a small chance, spawn a powerup. This functionality is found inside the game's `SpawnPowerUps` function:

```
GLboolean ShouldSpawn(GLuint chance)
{
    GLuint random = rand() \% chance;
```

```

return random == 0;
}
void Game::SpawnPowerUps(GameObject &block)
{
    if (ShouldSpawn(75)) // 1 in 75 chance
        this->PowerUps.push_back(
            PowerUp("speed", glm::vec3(0.5f, 0.5f, 1.0f), 0.0f, block.
Position, tex_speed
            ));
    if (ShouldSpawn(75))
        this->PowerUps.push_back(
            PowerUp("sticky", glm::vec3(1.0f, 0.5f, 1.0f), 20.0f, block.
Position, tex_sticky
            ));
    if (ShouldSpawn(75))
        this->PowerUps.push_back(
            PowerUp("pass-through", glm::vec3(0.5f, 1.0f, 0.5f), 10.0f,
block.Position, tex_pass
            ));
    if (ShouldSpawn(75))
        this->PowerUps.push_back(
            PowerUp("pad-size-increase", glm::vec3(1.0f, 0.6f, 0.4), 0.0f,
block.Position, tex_size
            ));
    if (ShouldSpawn(15)) // Negative powerups should spawn more often
        this->PowerUps.push_back(
            PowerUp("confuse", glm::vec3(1.0f, 0.3f, 0.3f), 15.0f, block.
Position, tex_confuse
            ));
    if (ShouldSpawn(15))
        this->PowerUps.push_back(
            PowerUp("chaos", glm::vec3(0.9f, 0.25f, 0.25f), 15.0f, block.
Position, tex_chaos
            ));
}

```

The `SpawnPowerUps` function creates a new `PowerUp` object based on a given chance (1 in 75 for normal powerups and 1 in 15 for negative powerups) and sets their properties. Each powerup is given a specific color to make them more recognizable for the user and a duration in seconds based on its type; here a duration of `0.0f` means its duration is infinite. Additionally, each powerup is given the position of the destroyed block and one of the textures of the previous section.

54.0.2 Activating PowerUps

Then we update the game's `DoCollisions` function to not only check for brick and paddle collisions, but also all collisions between the paddle and each non-destroyed `PowerUp`. Note that we call the `SpawnPowerUps` function as soon as a block is destroyed.

```

void Game::DoCollisions()
{
    for (GameObject &box : this->Levels[this->Level].Bricks)
    {
        if (!box.Destroyed)
        {
            Collision collision = CheckCollision(*Ball, box);
            if (std::get<0>(collision) // If collision is true

```

```

        {
            // Destroy block if not solid
            if (!box.IsSolid)
            {
                box.Destroyed = GL_TRUE;
                this->SpawnPowerUps (box);
            }
            [...]
        }
    }
}
[...]
for (PowerUp &powerUp : this->PowerUps)
{
    if (!powerUp.Destroyed)
    {
        if (powerUp.Position.y >= this->Height)
            powerUp.Destroyed = GL_TRUE;
        if (CheckCollision(*Player, powerUp))
        { // Collided with player, now activate powerup
            ActivatePowerUp (powerUp);
            powerUp.Destroyed = GL_TRUE;
            powerUp.Activated = GL_TRUE;
        }
    }
}
}
}

```

For all powerups not yet destroyed, we check if the powerup either reached the bottom edge of the screen or collided with the paddle. In both cases, the powerup is destroyed, but when collided with the paddle, it is also activated.

Activating a powerup is accomplished by settings its `Activated` property to true and enabling the powerup's effect by giving it to the `ActivatePowerUp` function:

```

void ActivatePowerUp(PowerUp &powerUp)
{
    // Initiate a powerup based type of powerup
    if (powerUp.Type == "speed")
    {
        Ball->Velocity *= 1.2;
    }
    else if (powerUp.Type == "sticky")
    {
        Ball->Sticky = GL_TRUE;
        Player->Color = glm::vec3(1.0f, 0.5f, 1.0f);
    }
    else if (powerUp.Type == "pass-through")
    {
        Ball->PassThrough = GL_TRUE;
        Ball->Color = glm::vec3(1.0f, 0.5f, 0.5f);
    }
    else if (powerUp.Type == "pad-size-increase")
    {
        Player->Size.x += 50;
    }
    else if (powerUp.Type == "confuse")
    {
        if (!Effects->Chaos)

```



```

        Effects->Confuse = GL_TRUE; // Only activate if chaos wasn't
already active
    }
    else if (powerUp.Type == "chaos")
    {
        if (!Effects->Confuse)
            Effects->Chaos = GL_TRUE;
    }
}

```

The purpose of `ActivatePowerUp` is exactly as it sounds: it activates the effect of a powerup as we've described somewhere at the start of this tutorial. We check the type of the powerup and change the game state accordingly. For the "sticky" and "pass-through" effect we also change the color of the paddle and the ball respectively to give the user some feedback as to which effect is currently active.

Because the sticky and pass-through effects slightly change the game logic we store their effect as a property of the ball object; this way we can change the game logic based on whatever effect on the ball is currently active. The only thing we change in the `BallObject` header is the addition of these two properties, but for completeness' sake its updated code is listed below:

- **BallObject:** [header](#), [code](#).

We can then easily implement the sticky effect by slightly updating the `DoCollisions` function at the collision code between the ball and the paddle:

```

if (!Ball->Stuck && std::get<0>(result))
{
    [...]
    Ball->Stuck = Ball->Sticky;
}

```

Here we set the ball's `Stuck` property equal to the ball's `Sticky` property. If the sticky effect is activated, the ball will end up stuck to the player paddle whenever it collides; the user then has to press the spacebar again to release the ball.

A similar small change is made for the pass-through effect within the same `DoCollisions` function. When the ball's `PassThrough` property is set to `true` we do not perform any collision resolution on the non-solid bricks.

```

Direction dir = std::get<1>(collision);
glm::vec2 diff_vector = std::get<2>(collision);
if (!(Ball->PassThrough && !box.IsSolid))
{
    if (dir == LEFT || dir == RIGHT) // Horizontal collision
    {
        [...]
    }
    else
    {
        [...]
    }
}

```

The other effects are activated by simply modifying a part of the game's state like the ball's velocity, the paddle's size or an effect of the `PostProcessor` object.

54.0.3 Updating PowerUps

Now all that is left to do is make sure that powerups are actually able to move once they've spawned and that they're deactivated as soon as their duration runs out; otherwise powerups will stay active forever.

Within the game's `UpdatePowerUps` function we move the powerups based on their velocity and decrease the active powerups their duration. Whenever a powerup's duration is decreased to `0.0f` its effect is deactivated and the relevant variables are set to their original state.

```

void Game::UpdatePowerUps(GLfloat dt)
{
    for (PowerUp &powerUp : this->PowerUps)
    {
        powerUp.Position += powerUp.Velocity * dt;
        if (powerUp.Activated)
        {
            powerUp.Duration -= dt;

            if (powerUp.Duration <= 0.0f)
            {
                // Remove powerup from list (will later be removed)
                powerUp.Activated = GL_FALSE;
                // Deactivate effects
                if (powerUp.Type == "sticky")
                {
                    if (!isOtherPowerUpActive(this->PowerUps, "sticky"))
                    { // Only reset if no other PowerUp of type sticky
                        is active
                            Ball->Sticky = GL_FALSE;
                            Player->Color = glm::vec3(1.0f);
                    }
                }
                else if (powerUp.Type == "pass-through")
                {
                    if (!isOtherPowerUpActive(this->PowerUps, "pass-through"))
                    { // Only reset if no other PowerUp of type pass-
                        through is active
                            Ball->PassThrough = GL_FALSE;
                            Ball->Color = glm::vec3(1.0f);
                    }
                }
                else if (powerUp.Type == "confuse")
                {
                    if (!isOtherPowerUpActive(this->PowerUps, "confuse"))
                    { // Only reset if no other PowerUp of type confuse
                        is active
                            Effects->Confuse = GL_FALSE;
                    }
                }
                else if (powerUp.Type == "chaos")
                {
                    if (!isOtherPowerUpActive(this->PowerUps, "chaos"))
                    { // Only reset if no other PowerUp of type chaos is
                        active
                            Effects->Chaos = GL_FALSE;
                    }
                }
            }
        }
    }
}

```

```

    }
}
this->PowerUps.erase(std::remove_if(this->PowerUps.begin(), this->
PowerUps.end(),
    [](const PowerUp &powerUp) { return powerUp.Destroyed && !powerUp.
Activated; }
), this->PowerUps.end());
}

```

You can see that for each effect we disable it by resetting the relevant items to their original state. We also set the powerup's `Activated` property to `false`. At the end of the `UpdatePowerUps` we then loop through the `PowerUps` vector and erase each powerup if they are destroyed **and** deactivated. We use the `remove_if` function from the `algorithm` header to erase these items given a lambda predicate.

The `remove_if` function moves all elements for which the lambda predicate is true to the end of the container object and returns an iterator to the start of this *removed elements* range. The container's `erase` function then takes this iterator and the vector's end iterator to remove all the elements between these two iterators.

It might happen that while one of the powerup effects is active, another powerup of the same type collides with the player paddle. In that case we have more than 1 powerup of that type currently active within the game's `PowerUps` vector. Then, whenever one of these powerups gets deactivated, we don't want to disable its effects yet since another powerup of the same type might still be active. For this reason we use the `IsOtherPowerUpActive` function to check if there is still another powerup active of the same type. Only if this function returns `false` we deactivate the powerup. This way, the powerup's duration of a given type is extended to the duration of its last activated powerup.

```

GLboolean IsOtherPowerUpActive(std::vector<PowerUp> &powerUps, std::string
type)
{
    for (const PowerUp &powerUp : powerUps)
    {
        if (powerUp.Activated)
            if (powerUp.Type == type)
                return GL_TRUE;
    }
    return GL_FALSE;
}

```

The function simply checks for all activated powerups if there is still any powerup active of the same type and if so returns `GL_TRUE`.

The last thing left to do is actually render the powerups:

```

void Game::Render()
{
    if (this->State == GAME_ACTIVE)
    {
        [...]
        for (PowerUp &powerUp : this->PowerUps)

```

```
        if (!powerUp.Destroyed)
            powerUp.Draw(*Renderer);
        [...]
    }
}
```

Combine all this functionality and we have a working powerup system that not only makes the game more fun, but also a lot more challenging. It'll look a bit like this:

See video online

You can find the updated game code below (there we also reset all powerup effects whenever the level is reset):

- **Game:** [header](#), [code](#).



55. Audio

No matter how hard we turn up the game's volume we most likely won't hear any audio from the game; we already have so much to show for, but without any audio the game still feels a bit empty. In this tutorial we're going to fix that.

OpenGL does not offer us any support for audio capabilities (like many other aspects of game development). We have to manually load audio files into a collection of bytes, process and convert them to an audio stream and manage multiple audio streams appropriately for use in our game. This is however slightly complicated and requires some low-level knowledge of audio engineering.

If it is your cup of tea then feel free to manually load audio streams from several audio file extensions. We are, however, going to make use of library for audio management called **irrKlang**.

55.1 Irrklang



IrrKlang is a high level 2D and 3D cross platform (Windows, Mac OS X, Linux) sound engine and audio library that plays WAV, MP3, OGG, and FLAC files to name a few. It also features several audio effects like reverb, delay and distortion that can be extensively tweaked.

3D audio means that an audio source can have a 3D position that will attenuate its volume based on the camera's distance to the audio source, making it feel natural in a 3D world (think of gunfire in a 3D world; most often you'll be able to hear where it came from just by the direction/location of the sound).

IrrKlang is an easy-to-use audio library that can play most audio files with just a few lines of code, making it a perfect candidate for our Breakout game. Note that irrKlang has a slightly restrictive license: you are allowed to use irrKlang as you see fit for non-commercial purposes, but you have to pay for their pro version whenever you want to use irrKlang commercially. Since Breakout and this tutorial series are non-commercial, we're freely allowed to use their standard library.

You can download irrKlang from their [download](#) page; we're going to use version 1.5. Because irrKlang is closed-source we cannot compile the library ourselves so we'll have to do with whatever irrKlang provided for us. Luckily they have plenty of precompiled library files so most of you should be just fine.

Once you included the header files of irrKlang, added their library (`irrKlang.lib`) to the linker settings and copied their dll files to the appropriate locations (usually the same location where the `.exe` resides) we're set to go. Note that if you want to load MP3 files you'll also have to include the `ikpMP3.dll` file.

55.1.1 Adding music

Specifically for this game I created a small little audio track so the game feels slightly more alive. You can find the audio track [here](#) that we'll use as the game's background music. This track is what we'll play whenever the game starts and that continuously loops until the player closes the game. Feel free to replace it with your own tracks or use it in any way you like.

You can find the audio online

Adding this to the Breakout game is extremely easy with the irrKlang library. We include the corresponding header files, create an `irrKlang::ISoundEngine`, initialize it with `createIrrKlangDevice` and then use the engine to load and play audio files:

```
#include <irrklang/irrKlang.h>
using namespace irrklang;

ISoundEngine *SoundEngine = createIrrKlangDevice();

void Game::Init()
{
    [...]
    SoundEngine->play2D("audio/breakout.mp3", GL_TRUE);
}
```

Here we created a `SoundEngine` that we use for all audio-related code. Once we've initialized the sound engine all we need to do to play audio is simply call its `play2D` function. Its first parameter is the filename and the second parameter whether we want the file to loop (play again once it's finished).

And that is all there is to it! Running the game should now cause your speakers or headset to violently blast out sound waves.

55.1.2 Adding sounds

We're not there yet, since music by itself is not enough to make the game completely feel alive. We want to play sounds whenever something interesting happens in the game, as some extra feedback to the player. Like when we hit a brick, or when we activate a powerup and so on. Below you can find all the sounds we're going to use (courtesy of freesound.org):

bleep.mp3: the sound for when the ball hit a non-solid block.

You can find the audio online

solid.wav: the sound for when the ball hit a solid block.

You can find the audio online

powerup.wav: the sound for when we the player paddle collided with a powerup block.

You can find the audio online

bleep.wav: the sound for when we the ball bounces of the player paddle.

You can find the audio online

Wherever a collision occurs, we play the corresponding sound. I won't walk through each of the lines of code where this is supposed to happen, but simply list the updated game code [here](#). You should easily be able to add the sound effects at their corresponding locations.

Putting it all together gives us a game that feels a lot more complete. All together it looks (and sounds) like this:

See video online

IrrKlang allows for much more fine-grained control of audio controls like advanced memory management, audio effects or sound event callbacks. Check out their simple C++ [tutorials](#) and try to experiment with its features.



56. Render text

In this tutorial we're adding the final enhancements to the game by adding a life system, a win condition and feedback in the form of rendered text. This tutorial heavily builds upon the earlier introduced [Text Rendering](#) tutorial so it is highly advised to first work your way through that tutorial if you haven't already.

In Breakout all text rendering code is encapsulated within a class called `TextRenderer` that features the initialization of the FreeType library, render configuration and the actual render code. You can find the code of the `TextRenderer` class below:

- **TextRenderer:** [header](#), [code](#).

The content of the text renderer's functions is almost exactly the same as the code from the text rendering tutorial. However, the code for rendering glyphs onto the screen is slightly different:

```
void TextRenderer::RenderText(std::string text, GLfloat x, GLfloat y,
    GLfloat scale, glm::vec3 color)
{
    [...]
    for (c = text.begin(); c != text.end(); c++)
    {
        GLfloat xpos = x + ch.Bearing.x * scale;
        GLfloat ypos = y + (this->Characters['H'].Bearing.y - ch.Bearing.y)
            * scale;

        GLfloat w = ch.Size.x * scale;
        GLfloat h = ch.Size.y * scale;
        // Update VBO for each character
        GLfloat vertices[6][4] = {
            { xpos,      ypos + h, 0.0, 1.0 },
            { xpos + w,  ypos,      1.0, 0.0 },
            { xpos,      ypos,      0.0, 0.0 },

            { xpos,      ypos + h, 0.0, 1.0 },
```



```

        { xpos + w, ypos + h, 1.0, 1.0 },
        { xpos + w, ypos,      1.0, 0.0 }
    };
    [...]
}

```

The reason for it being slightly different is that we use a different orthographic projection matrix than the one we've used in the text rendering tutorial. In the text rendering tutorial, all y values ranged from bottom to top while in the Breakout game all y values range from top to bottom with a y coordinate of 0.0 corresponding to the top edge of the screen. This means we have to slightly modify how we calculate the vertical offset.

Since we now render downwards from `RenderText`'s y parameter we calculate the vertical offset as the distance a glyph is pushed downwards from the top of the glyph space. Looking back at the glyph metrics image from FreeType this is indicated by the red arrow:

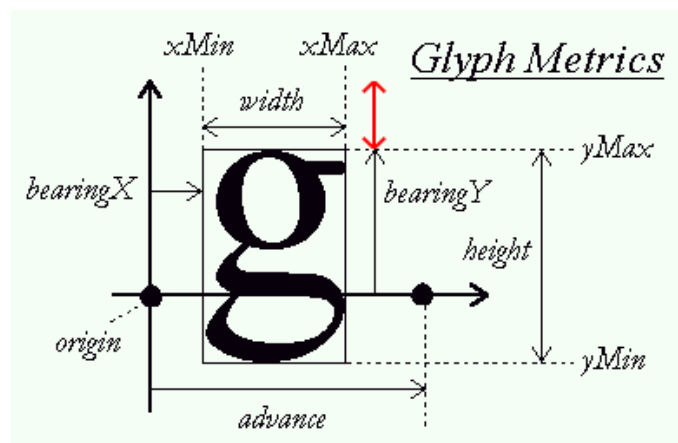

To calculate this vertical offset we need to get the top of the glyph space (basically the length of the black vertical arrow from the origin). Unfortunately, FreeType has no such metric for us. What we do know is that some glyphs always touch this top edge; characters like 'H', 'T' or 'X'. So what if we calculate the length of this red vector by subtracting `bearingY` from any of these *top-reaching* glyphs by `bearingY` of the glyph in question. This way, we push the glyph down based on how far its top point differs from the top edge.

```

GLfloat ypos = y + (this->Characters['H'].Bearing.y - ch.Bearing.y) * scale
;

```

Aside from updating the `ypos` calculation we also switched the order of the vertices a bit around to make sure all the vertices are still front facing when multiplied with the current orthographic projection matrix (as discussed in the [face culling](#) tutorial).

Adding the `TextRenderer` to the game is easy:

```

TextRenderer *Text;

void Game::Init()
{
    [...]
    Text = new TextRenderer(this->Width, this->Height);
}

```

```
Text->Load("fonts/ocraext.TTF", 24);
}
```

The text renderer is initialized with a font called OCR A Extended that you can download from [here](#). If the font is not to your liking feel free to use a different font.

Now that we have a text renderer, let's finish the gameplay mechanics.

56.1 Player lives

Instead of immediately resetting the game as soon as the ball reaches the bottom edge, we'd like to give the player a few extra chances. We do this in the form of player lives, where the player begins with an initial number of lives (say 3) and each time the ball touches the bottom edge the player's life total is decreased by 1. Only when the player's life total becomes 0 we reset the game. This makes it easier for the player to finish a level while also building tension.

We keep count of the lives of a player by adding it to the game class (initialized within the constructor to a value of 3):

```
class Game
{
    [...]
public:
    GLuint Lives;
}
```

We then modify the game's `Update` function to, instead of resetting the game, decrease the player's life total and only reset the game once the life total reached 0:

```
void Game::Update(GLfloat dt)
{
    [...]
    if (Ball->Position.y >= this->Height) // Did ball reach bottom edge?
    {
        --this->Lives;
        // Did the player lose all his lives? : Game over
        if (this->Lives == 0)
        {
            this->ResetLevel();
            this->State = GAME_MENU;
        }
        this->ResetPlayer();
    }
}
```

As soon as the player is game over (lives equal to 0) we reset the level and change the game state to `GAME_MENU` which we'll get to later.

Don't forget to reset the player's life total as soon as we reset the game/level:

```
void Game::ResetLevel()
{
    [...]
}
```

```
this->Lives = 3;
}
```

The player now has a working life total, but has no way of seeing how many lives he currently has while playing the game. That's where the text renderer comes in.

```
void Game::Render ()
{
    if (this->State == GAME_ACTIVE)
    {
        [...]
        std::stringstream ss; ss << this->Lives;
        Text->RenderText("Lives:" + ss.str(), 5.0f, 5.0f, 1.0f);
    }
}
```

Here we convert the number of lives to a string and display it at the top-left of the screen. It'll now look a bit like this:



As soon as the ball touches the bottom edge, the player's life total is decreased which is instantly visible at the top-left of the screen.

56.2 Level selection

Whenever the user is in the game state `GAME_MENU` we'd like to give the player the control to select the level he'd like to play in. With either the 'w' or 's' key the player should be able to scroll through any of the levels we loaded. Whenever the player feels like the chosen level is indeed the

level he'd like to play in he can press the enter key to switch from the game's `GAME_MENU` state to the `GAME_ACTIVE` state.

Allowing the player to choose a level is not too difficult. All we have to do is increase or decrease the game class's `Level` variable based on whether he pressed 'w' or 's' respectively:

```
if (this->State == GAME_MENU)
{
    if (this->Keys[GLFW_KEY_ENTER])
        this->State = GAME_ACTIVE;
    if (this->Keys[GLFW_KEY_W])
        this->Level = (this->Level + 1) \% 4;
    if (this->Keys[GLFW_KEY_S])
        this->Level = (this->Level - 1) \% 4;
}
```

We use the modulus operator (%) to make sure the `Level` variable remains within the acceptable level range (between 0 and 3). Aside from switching levels we also want to define what we want to render when we're in the menu state. We'd like to give the player some instructions in the form of text and also display the selected level in the background.

```
void Game::Render()
{
    if (this->State == GAME_ACTIVE || this->State == GAME_MENU)
    {
        [...] // Game state's rendering code
    }
    if (this->State == GAME_MENU)
    {
        Text->RenderText("Press ENTER to start", 250.0f, Height / 2, 1.0f);
        Text->RenderText("Press W or S to select level", 245.0f, Height / 2
            + 20.0f, 0.75f);
    }
}
```

Here we render the game whenever we're in either the `GAME_ACTIVE` state or the `GAME_MENU` state and whenever we're in the `GAME_MENU` state we also render two lines of text to inform the player to select a level and/or accept his choice. Note that for this to work when launching the game you do have to set the game's state as `GAME_MENU` by default.



It looks great, but once you try to run the code you'll probably notice that as soon as you press either the 'w' or the 's' key the game rapidly scrolls through the levels making it difficult to select the level you want to play in. This happens because the game records the key press for multiple frames until we release the key. This causes the `ProcessInput` function to process the pressed key more than once.

We can solve this issue with a little trick commonly found within GUI systems. The trick is to not only record the keys currently pressed, but also storing the keys that have been processed once, until released again. We then check (before processing) whether the key has not yet been processed, and if so, process this key after which we store this key as being processed. Once we want to process the same key again without the key having been released, we do not process the key. This probably sounds slightly confusing, but as soon as you see it in practice it (probably) starts to make sense.

First we have to create another array of bool values to indicate which keys have been processed. We define this within the game class:

```
class Game
{
    [...]
    public:
        GLboolean KeysProcessed[1024];
}
```

We then set the relevant key(s) to `true` as soon as they're processed and make sure to only process the key if it wasn't processed before (until released):

```

void Game::ProcessInput(GLfloat dt)
{
    if (this->State == GAME_MENU)
    {
        if (this->Keys[GLFW_KEY_ENTER] && !this->KeysPressed[GLFW_KEY_ENTER])
        {
            this->State = GAME_ACTIVE;
            this->KeysProcessed[GLFW_KEY_ENTER] = GL_TRUE;
        }
        if (this->Keys[GLFW_KEY_W] && !this->KeysProcessed[GLFW_KEY_W])
        {
            this->Level = (this->Level + 1) \% 4;
            this->KeysProcessed[GLFW_KEY_W] = GL_TRUE;
        }
        if (this->Keys[GLFW_KEY_S] && !this->KeysProcessed[GLFW_KEY_S])
        {
            this->Level = (this->Level - 1) \% 4;
            this->KeysProcessed[GLFW_KEY_S] = GL_TRUE;
        }
        [...]
    }
}

```

Now as soon as the key's value in the `KeysProcessed` array has not yet been set, we process the key and set its value to `true`. Next time we reach the `if` condition of the same key, it will have been processed so we'll pretend we never pressed the button until it's released again.

Within GLFW's key callback function we then need to reset the key's processed value as soon as its released so we can process it again the next time it's pressed:

```

void key_callback(GLFWwindow* window, int key, int scancode, int action,
int mode)
{
    [...]
    if (key >= 0 && key < 1024)
    {
        if (action == GLFW_PRESS)
            Breakout.Keys[key] = GL_TRUE;
        else if (action == GLFW_RELEASE)
        {
            Breakout.Keys[key] = GL_FALSE;
            Breakout.KeysProcessed[key] = GL_FALSE;
        }
    }
}

```

Launching the game gives us a neat level select screen that now precisely selects a single level per key press no matter how long we press the key.

56.3 Winning

Currently the player is able to select levels, play the game and fail in doing so to lose. It is kind of unfortunate if the player finds out after destroying all the bricks he cannot in any way win the game. So let's fix that.

The player wins when all of the non-solid blocks have been destroyed. We already created a function to check for this condition with the `GameLevel` class:

```
GLboolean GameLevel::IsCompleted()
{
    for (GameObject &tile : this->Bricks)
        if (!tile.IsSolid && !tile.Destroyed)
            return GL_FALSE;
    return GL_TRUE;
}
```

We check all bricks in the game level and if a single non-solid brick is not destroyed we return false. All we have to do is check for this condition in the game's `Update` function and as soon as it returns true we change the game state to `GAME_WIN`:

```
void Game::Update(GLfloat dt)
{
    [...]
    if (this->State == GAME_ACTIVE && this->Levels[this->Level].IsCompleted())
    {
        this->ResetLevel();
        this->ResetPlayer();
        Effects->Chaos = GL_TRUE;
        this->State = GAME_WIN;
    }
}
```

Whenever the level is completed while the game is active we reset the game and display a small victory message in the `GAME_WIN` state. For fun we'll enable the chaos effect while in the `GAME_WIN` screen. In the `Render` function we'll congratulate the player and ask him to either restart or quit the game:

```
void Game::Render()
{
    [...]
    if (this->State == GAME_WIN)
    {
        Text->RenderText(
            "You WON!!!", 320.0, Height / 2 - 20.0, 1.0, glm::vec3(0.0,
            1.0, 0.0)
        );
        Text->RenderText(
            "Press ENTER to retry or ESC to quit", 130.0, Height / 2, 1.0,
            glm::vec3(1.0, 1.0, 0.0)
        );
    }
}
```

Then we of course have to actually catch the mentioned keys:

```
void Game::ProcessInput(GLfloat dt)
{
    [...]
    if (this->State == GAME_WIN)
    {
```

```
if (this->Keys[GLFW_KEY_ENTER])
{
    this->KeysProcessed[GLFW_KEY_ENTER] = GL_TRUE;
    Effects->Chaos = GL_FALSE;
    this->State = GAME_MENU;
}
}
```

If you can then actually manage to win the game you'd get the following image:

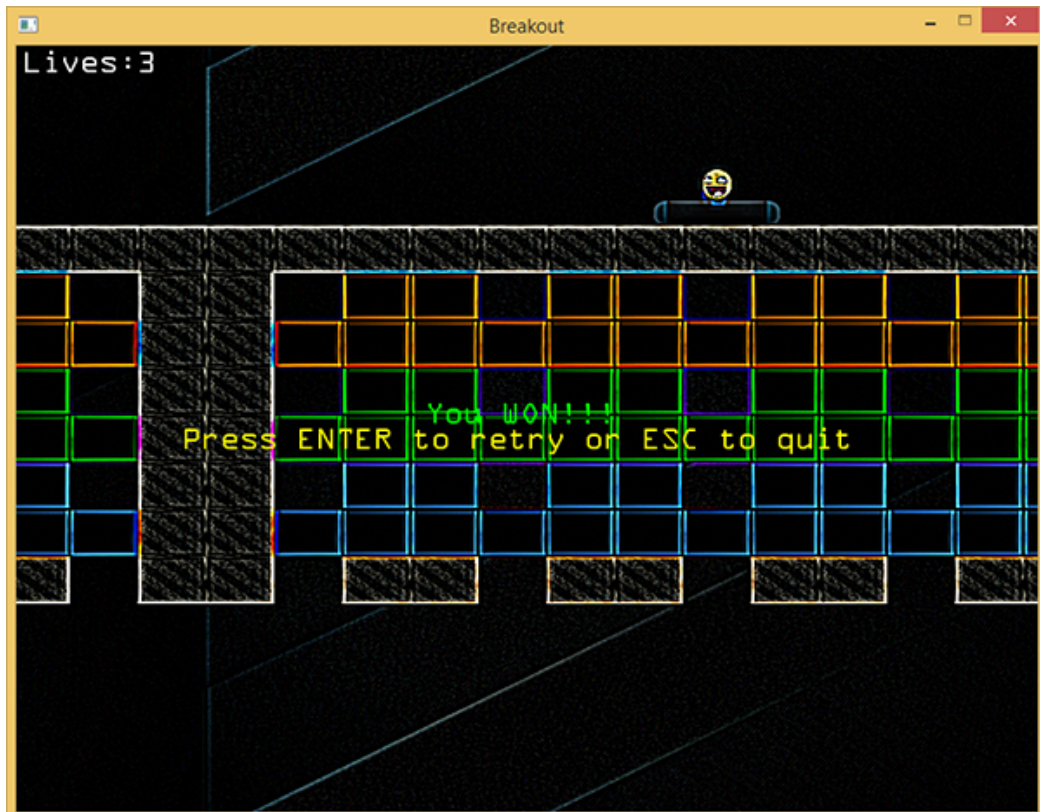

And that is it! The final piece of the puzzle of the Breakout game we've been working on. Try it out, customize it to your liking and show it to all your family and friends!

You can find the final version of the game's code below:

- **Game:** [header](#), [code](#).

A futuristic cityscape with a flying vehicle in the foreground. The city is composed of tall, thin buildings, and the sky is a mix of blue and grey. A dark, sleek flying vehicle with blue lights is in the lower-left foreground, flying towards the right. The background is a dense forest of tall, thin buildings, some with windows, under a cloudy sky.

57. Final thoughts

These last tutorials gave a glimpse of what it's like to create something more than just a tech demo in OpenGL. We created a complete 2D game from scratch and learned how to abstract from certain low-level graphics concepts, use basic collision detection techniques, create particles and we've shown a practical scenario for an orthographic projection matrix. All this using concepts we've discussed in the previous tutorial series. We did not really learn new and exciting graphics techniques using OpenGL, but more as to how to combine all the knowledge so far into a larger whole.

Creating a simple game like Breakout can be accomplished in thousands of different ways of which this approach is just one of many. The larger a game becomes, the more you start applying abstractions and design patterns. For further reading you can find most of these abstractions and design patterns in the wonderful [game programming patterns](#) website.

Keep in mind that it is a difficult feat to create a game with extremely clean and well-thought out code (often close to impossible). Simply make your game in whatever way you think feels right at the time. The more you practice video-game development the more you learn new and better approaches to solve problems. Don't let the struggle to want to create perfect code demotivate you; keep on coding!

57.1 Optimizations

The content of these tutorials and the finished game code were all focused on explaining concepts as simple as possible without delving much into optimization details. Therefore, many performance considerations were left out of the tutorials. We'll list some of the more common improvements you'll find in modern 2D OpenGL games to boost performance for when your framerate starts to drop:

- **Sprite sheet / Texture atlas:** instead of rendering a sprite with a single texture at a time we combine all required textures into a single large texture (like bitmap fonts) and select the appropriate sprite texture with a targeted set of texture coordinates. Switching texture states can be expensive so a sprite sheet makes sure we rarely have to switch between textures; this also allows the GPU to more efficiently cache the texture in memory for faster lookups.
- **Instanced rendering:** instead of rendering a quad at a time, we could've also **batched** all the quads we want to render and then with an **instanced renderer** render all the batched sprites with just a single draw call. This is easily possible since each sprite is composed of the same vertices, but differs in only a model matrix; something that we can easily include in an instanced array. This allows OpenGL to render a lot more sprites per frame. Instanced rendering can also be used to render particles and/or characters glyphs.
- **Triangle strips:** instead of rendering each quad as two triangles, we could've rendered them with OpenGL's `TRIANGLE_STRIP` render primitive that takes only 4 vertices instead of 6 to render a quad. This saves a third of the data sent to the GPU.
- **Space partitioning algorithms:** when checking possible collisions we compare the ball object to **each** of the bricks in the active level which is a bit of a waste of CPU resources since we can easily tell that most of the bricks won't even come close to the ball within this frame. Using **space partitioning algorithms** like BSP, Octrees or k-d trees we partition the visible space into several smaller regions and determine in which region(s) the ball is in. We then only check collisions between other bricks in whatever region(s) the ball is in, saving us a significant amount of collision checks. For a simple game like Breakout this will likely be overkill, but for more complicated games with more complicated collision detection algorithms this will significantly increase performance.
- **Minimize state changes:** state changes (like binding textures or switching shaders) are generally quite expensive in OpenGL so you want to avoid doing a large amount of state changes. One approach to minimize state changes is to create your own state manager that stores the current value of an OpenGL state (like which texture is bound) and only switch if this value needs to change; this prevents unnecessary state changes. Another approach is to sort all the renderable objects by state change: first render all the objects with shader one, then all objects with shader two and so on; this can all of course be extended to shaders, texture binds, framebuffer switches etc.

These should give you some hints as to what kind of advanced tricks we can apply to further boost the performance of a 2D game. This also gives you a glimpse of the power of OpenGL: by doing most rendering by hand we have full control over how we accomplish the entire process and thus also complete power over how to optimize the process. If you're not satisfied with Breakout's performance then feel free to take any of these as an exercise.

57.2 Get creative

Now that you've seen how to create a simple game in OpenGL it is up to you to create your own rendering/game applications. Many of the techniques that we've discussed so far can be used in most 2D games like sprite rendering, basic collision detection, postprocessing, text rendering and particles. It is now up to you to take these techniques and combine/modify them in whichever way you think is right and develop your own handcrafted game.